

ISSN 1088-3800

Effects of the 1985 Michoacan Earthquake on Water Systems and Other Buried Pipelines in Mexico

by

A.G. Ayala and M.J. O'Rourke

Technical Report NCEER-89-0009

March 8, 1989

This research was conducted at Rensselaer Polytechnic Institute and was supported in whole or in part by the National Science Foundation under grant number ECE 86-07591.

NOTICE

This report was prepared by Rensselaer Polytechnic Institute as a result of research sponsored by the National Center for Earthquake Engineering Research (NCEER) through a grant from the National Science Foundation, and other sponsors. Neither NCEER, associates of NCEER, its sponsors, Rensselaer Polytechnic Institute nor any person acting on their behalf:

- a. makes any warranty, express or implied, with respect to the use of any information, apparatus, method, or process disclosed in this report or that such use may not infringe upon privately owned rights; or
- b. assumes any liabilities of whatsoever kind with respect to the use of, or the damage resulting from the use of, any information, apparatus, method, or process disclosed in this report.

Any opinions, findings, and conclusions or recommendations expressed in this publication are those of the author(s) and do not necessarily reflect the views of NCEER, the National Science Foundation, or other sponsors.

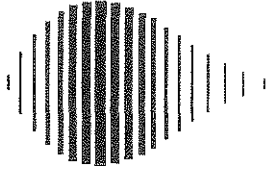

**EFFECTS OF THE 1985 MICHOACAN EARTHQUAKE
ON WATER SYSTEMS AND OTHER BURIED LIFELINES IN MEXICO**

by

A. Gustavo Ayala¹ and Michael J. O'Rourke²

March 8, 1989

Technical Report NCEER-89-0009

NCEER Contract Number 87-3006

NSF Master Contract Number ECE 86-07591

- 1 Visiting Professor, Dept. of Civil Engineering, Rensselaer Polytechnic Institute
2 Associate Professor, Dept. of Civil Engineering, Rensselaer Polytechnic Institute

NATIONAL CENTER FOR EARTHQUAKE ENGINEERING RESEARCH
State University of New York at Buffalo
Red Jacket Quadrangle, Buffalo, NY 14261

PREFACE

The National Center for Earthquake Engineering Research (NCEER) is devoted to the expansion and dissemination of knowledge about earthquakes, the improvement of earthquake-resistant design, and the implementation of seismic hazard mitigation procedures to minimize loss of lives and property. The emphasis is on structures and lifelines that are found in zones of moderate to high seismicity throughout the United States.

NCEER's research is being carried out in an integrated and coordinated manner following a structured program. The current research program comprises four main areas:

- Existing and New Structures
- Secondary and Protective Systems
- Lifeline Systems
- Disaster Research and Planning

This technical report pertains to Program 3, Lifeline Systems, and more specifically to water delivery systems.

The safe and serviceable operation of lifeline systems such as gas, electricity, oil, water, communication and transportation networks, immediately after a severe earthquake, is of crucial importance to the welfare of the general public, and to the mitigation of seismic hazards upon society at large. The long-term goals of the lifeline study are to evaluate the seismic performance of lifeline systems in general, and to recommend measures for mitigating the societal risk arising from their failures.

From this point of view, Center researchers are concentrating on the study of specific existing lifeline systems, such as water delivery and crude oil transmission systems. The water delivery system consists of two parts. The first studies the seismic performance of water delivery systems on the west coast. While the second part addresses itself to the seismic performance of the water delivery system in Memphis, Tennessee. For both systems, post-earthquake fire fighting capabilities will be considered as a measure of seismic performance.

The components of the water delivery system study are shown in the accompanying figure.

Program Elements:

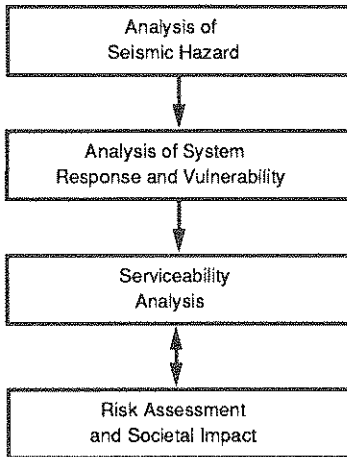

Tasks:

Wave Propagation, Fault Crossing
Liquefaction and Large Deformation
Above- and Under-ground Structure Interaction
Spatial Variability of Ground Motion

Soil-Structure Interaction, Pipe Response Analysis
Statistics of Repair/Damage
Post-Earthquake Data Gathering Procedure
Leakage Tests, Centrifuge Tests for Pipes

Post-Earthquake Firefighting Capability
System Reliability
Computer Code Development and Upgrading
Verification of Analytical Results

Mathematical Modeling
Socio-Economic Impact

This study investigates the effects of the 1985 Michoacan earthquake on water delivery systems in the metropolitan Mexico City area. Damage statistics for buried segmented pipes are correlated with soil conditions and earthquake characteristics. Seismic effects on welded steel pipes, sewer and underground metro lifelines are also discussed. A historical account of seismic damage to the Mexican water system due to past earthquakes is also provided. This report highlights the importance of such a historical perspective for an understanding of the seismic vulnerability of these types of systems.

ABSTRACT

In this report the effects of the 1985 Michoacan Earthquake on water systems in Mexico are investigated. Because the damage from the 1985 event was most severe in Mexico city, the report concentrates on the Metropolitan Mexico City Area. A historical perspective is provided by information about seismic damage to Mexican water systems due to past earthquakes. This historical perspective highlights the seismic vulnerability of these types of systems.

The effects of the earthquake on water supply as well as some aspects of the emergency response are discussed. Soil conditions in Mexico City and the characteristics of the earthquake are investigated and correlated with the observed damage. Damage statistics are presented for the buried segmented pipelines in the water system. Other sections are devoted to damage to a continuous (welded steel) pipeline and to seismic effects on the sewer and underground Metro lifelines.

Seismic damage to lifelines in the epicentral region was relatively light. A comparison of ground motion characteristics recorded in Mexico City and in the epicentral region is used to explain these differences. Finally, a general summary and recommendations to reduce the seismic vulnerability of the Mexico City water system as well as other water systems are given.

ACKNOWLEDGEMENTS

This investigation was possible due to the contributions of many people. Government officials at the General Directorate of Hydraulic Construction and Operation, DGCOH, of the Federal District Government and the State Commission of Water And Sanitation (CEAS) in the State of Mexico were especially helpful. The assistance of Mr. J.A. Escobar a graduate student at the Institute of Engineering, UNAM, in gathering and organizing the existing information is acknowledged. Finally this report was prepared while the first author was a visiting professor at RPI under the sponsorship of the National Center for Earthquake Engineering Research.

TABLE OF CONTENTS

SECTION	TITLE	PAGE
1	INTRODUCTION	1-1
2	WATER SYSTEM DAMAGE DUE TO PRIOR EARTHQUAKES	2-1
3	METROPOLITAN MEXICO CITY WATER SUPPLY SYSTEM	3-1
3.1	Federal District	3-1
3.2	State of Mexico	3-6
4	WATER SERVICE DISRUPTION DUE TO THE 1985 MICHOACAN EARTHQUAKE	4-1
4.1	Federal District	4-1
4.2	State of Mexico	4-2
4.3	Repair Techniques	4-2
5	SUBSOIL CONDITIONS IN METROPOLITAN MEXICO CITY AND CHARACTERISTICS OF THE 1985 MICHOACAN EARTHQUAKE	5-1
5.1	Subsoil Conditions	5-1
5.2	Characteristics of the Earthquake Motions	5-4
6	WATER SYSTEM DAMAGE IN METROPOLITAN MEXICO CITY; SEGMENTED PIPELINES	6-1
6.1	Segmented Transmission System Damage	6-1
6.1.1	Federal District Aqueduct	6-4
6.1.2	Comision de Aguas del Valle de Mexico Aqueduct	6-4
6.1.3	Analysis of Transmission Systems Damage	6-10
6.2	Distribution Systems Damage	6-17
6.2.1	Primary Distribution Pipelines in D.F.	6-17
6.2.2	Secondary Distribution Pipelines in D.F.	6-22
6.2.3	Distribution Pipelines in the State of Mexico	6-22
6.3	Service Connections	6-28
6.4	Subsidence	6-32
6.5	Comparisons with Other Earthquakes	6-37
7	WELDED STEEL PIPELINE DAMAGE	7-1
7.1	Physical Characteristics and Observed Damage	7-1
7.2	Stress Analysis	7-3
7.2.1	Soil Strain	7-3
7.2.2	Frictional Strain	7-11
7.3	Critical Local Buckling Stress	7-16
7.4	Case Study Summary	7-17
8	DAMAGE TO OTHER BURIED LIFELINES IN METROPOLITAN MEXICO CITY	8-1
8.1	Sewer System Damage	8-1
8.2	Underground Metro Damage	8-2

TABLE OF CONTENTS (Continued)

SECTION	TITLE	PAGE
9	WATER SYSTEM DAMAGE IN EPICENTRAL AREA	9-1
9.1	Observed Damage	9-1
9.2	Analysis of Damage	9-5
10	SUMMARY AND RECOMMENDATIONS	10-1
10.1	Summary	10-1
10.2	Recommendations	10-2
11	REFERENCES	11-1

LIST OF FIGURES

FIGURE	TITLE	PAGE
2-1	Growth of Metropolitan Mexico City 1524-1980	2-4
2-2	Aqueduct Damage During 1979 Guerrero Earthquake	2-5
2-3	Aqueduct Damage During 1979 Guerrero Earthquake	2-6
3-1	Water Supply for Metropolitan Mexico City	3-2
3-2	Recycled Waste Water Distribution Network	3-4
3-3	Aqueducts and Primary Distribution Lines Controlled by the Federal District	3-5
3-4	Water Distribution System in Ciudad Nezahualcoyotl (E.de.M.)	3-7
3-5	Water Distribution System in Municipio de Ecatepec (E.de.M.)	3-8
4-1	Water Tank Truck Distributing Water to Affected Population	4-4
4-2	Water Service Disruption in Federal District as of October 2, 1985	4-5
4-3	Distribution of Sealed Plastic Bags with Purified Water	4-6
4-4	Steel Saddle on Damaged Pipe	4-8
5-1	Soil Zones for Metropolitan Mexico City	5-2
5-2	Soil Profiles for Metropolitan Mexico City	5-3
5-3	Lines of Equal Depth to Deep Deposits (in Meters)	5-5
5-4	Lines of Equal Site Response Period (in Seconds)	5-6
5-5	Epicenter Location for Michoacan Earthquake	5-7
5-6	Movement of Plates	5-8
5-7	Location of Strong Motion Instruments in the Valley of Mexico	5-9
6-1	Aqueducts in Southeastern Mexico City Controlled by the Federal District	6-2
6-2	Aqueducts in Southeastern Mexico City Controlled by C.A.V.M.	6-3
6-3	Joint Separation in a 72"φ 'Lock Joint' Pipe, 1985 Michoacan Earthquake	6-5
6-4	Crushing Failure in a 72"φ 'Lock Joint' Pipe, 1985 Michoacan Earthquake	6-6
6-5	Joint Separation at 11 Points Close to a "T" Junction, 1985 Michoacan Earthquake	6-7
6-6	Severe Ground Cracking in the Vicinity of the Aqueducts, 1985 Michoacan Earthquake	6-8
6-7	Cracking at a Valve Box Wall	6-9
6-8	Location of Damaged Aqueducts with Respect to Surrounding Mountains	6-11
6-9	Idealized Elevation View Showing Tlahuac	6-12

LIST OF FIGURES (Continued)

FIGURE	TITLE	PAGE
6-10	North-South Ground Displacement Time Histories at Tlahuac - 1985 Michoacan Earthquake	6-14
6-11	East-West Ground Displacement Time History at Tlahuac - 1985 Michoacan Earthquake	6-15
6-12	View of a Steel Repair Saddle	6-16
6-13	Fractured Cast Iron "T", 1985 Michoacan Earthquake	6-18
6-14	Well Documented Pipeline Damage in Primary Distribution System of Federal District - 1985 Michoacan Earthquake	6-23
6-15	Areas of Secondary Distribution System Damage - 1985 Michoacan Earthquake	6-24
6-16	Leak at the Bell of an Asbestos Cement Pipe, 1985 Michoacan Earthquake	6-25
6-17	Break Near Joint of an Asbestos Cement Pipe, 1985 Michoacan Earthquake	6-26
6-18	Repaired Leak at a Valve Box	6-29
6-19	Well Damage at 'La Caldera' Tank, 1985 Michoacan Earthquake	6-30
6-20	Typical Residential Service in the State of Mexico (E.de.M.)	6-33
6-21	Settlement vs. Time for Two Sites in Mexico City (After [5])	6-34
6-22	Contours of Equal Subsidence in Old Mexico City as of 1970 (After [5])	6-35
6-23	Ground Strain in Old Mexico City Due to Subsidence as of 1970	6-36
6-24	Pipe Repairs per km. vs. Peak Ground Acceleration for Lake Zone in Mexico City 1985 and Other Historic Earthquakes	6-38
6-25	Damage Ratio vs. Peak Ground Velocity, Mexico City 1985	6-39
6-26	Damage Ratio vs. Pipe Diameter, Mexico City 1985	6-40
7-1	Estimated Soil Profile for Ciudad Nezahualcoyotl	7-2
7-2	Local Buckling Failure of Ciudad Nezahualcoyotl Pipeline - 1985 Michoacan Earthquake	7-4
7-3	Wrinkling Deformation Close to a Valve Location, Ciudad Nezahualcoyotl Pipeline, 1985 Michoacan Earthquake	7-5
7-4	Broken Butterfly Valve	7-6
7-5	Reported Failures Along Steel Pipelines in Ciudad Nezahualcoyotl (E.de.M.) in 1985	7-7
7-6	North-South Velocity Time Histories in Hill and Lake Zones of Mexico City - 1985 Michoacan Earthquake	7-9
7-7	East-West Velocity Time Histories in Hill and Lake Zones of Mexico City - 1985 Michoacan Earthquake	7-10

LIST OF FIGURES (Continued)

FIGURE	TITLE	PAGE
7-8	R-wave Dispersion Curve for Ciudad Nezahualcoyotl Site	7-12
7-9	Soil and Friction Strain for Ciudad Nezahualcoyotl Pipeline	7-15
9-1	Water System Damage in Epicentral Region - 1985 Michoacan Earthquake	9-2
9-2	Damage to a Well, Epicentral Region - 1985 Michoacan Earthquake	9-3
9-3	Damage to a 72"φ Above Ground Pipeline, Epicentral Region, 1985 Michoacan Earthquake	9-4
9-4	North-South Acceleration Time Histories in Epicentral Region and Mexico City - 1985 Michoacan Earthquake ..	9-7
9-5	East-West Acceleration Time Histories in Epicentral Region and Mexico City, 1985 Michoacan Earthquake ...	9-8

LIST OF TABLES

TABLE	TITLE	PAGE
2-I	Historic Earthquake Damage to Water Systems in Mexico, [3]	2-3
4-I	'Colonias' in Metropolitan Mexico City Without Water Supply as of October 2, 1985	4-3
5-I	Maximum Horizontal Accelerations, Velocities and Displacements Recorded in the Valley of Mexico City - 1985 Michoacan Earthquake	5-11
5-II	Average Values of Peak Ground Motion Parameters for the Valley of Mexico by Zone (1985 Michoacan Earthquake)	5-12
6-I	Pipeline Lengths for the Primary Distribution System in the Federal District (D.F.)	6-19
6-II	Leak Rate and Number of Leaks for Primary Distribution System Lines in the Federal District ...	6-20
6-III	Summary of Damage Statistics for the Primary Distribution Network in the Federal District	6-21
6-IV	Number of Leaks/Breaks per 'Delegacion' in the Secondary Distribution System in the Federal District	6-27
6-V	Available Damage Statistics for the Municipio de Ecatepec	6-31
6-VI	Damage Ratio and Maximum Ground Velocities for Different Soil Conditions	6-41
7-I	Calculation of Soil Strain vs. Quarter Wavelength Separation Distance for Ciudad Nezahualcoyotl Site ..	7-13

SECTION I INTRODUCTION

During the Michoacan earthquake of September 19, 1985, the water supply and distribution systems of Metropolitan Mexico City were severely damaged. The disaster left an estimated 5.3 million people without water, a condition never previously experienced in a major city.

Damage to above ground structures was of enormous proportions, capturing most of the international interest. However, the amount of physical damage to the water system as well as the effects this damage had upon the population also represent a very important issue. It is quite possible that catastrophic consequences would have resulted if adequate actions had not been taken. This fact makes evident the necessity of investigating and learning from the experience of Mexico City. Through an analysis of this event, the main factors involved in the seismic vulnerability of water systems can be understood, problem areas and solutions can be identified, and recommendations for the seismic design of new systems and the upgrading of the existing systems can be proposed.

This report presents a thorough investigation of the available information on underground lifeline damage caused by the Michoacan earthquake in both the epicentral region and in Metropolitan Mexico City. For Mexico City, information is presented for the Federal District as well as the part of the city within the State of Mexico. The resulting reduction in supply and distribution capability as well as some of its effect on the population are given. Statistics on breaks/leaks occurring in aqueducts, distribution networks and service connections are presented. Where appropriate, observed damage is correlated with local soil conditions and earthquake characteristics. The available information is presented and general conclusion regarding water system seismic vulnerability are drawn.

SECTION 2
WATER SYSTEM DAMAGE DUE TO PRIOR EARTHQUAKES

In this section, damage to water systems in Mexico caused by earthquakes prior to the September 1985 event is discussed. The recorded evidence suggests that, as in contemporary systems, the lack of flexibility (ductility) at pipeline joints was a major cause of pipeline damage in past earthquakes.

Damage to water supply and distribution systems in Mexico caused by destructive earthquakes has been documented to a greater or lesser extent since 1818. Information on water system damage before 1818 is not available although there is a 500 year record of earthquakes in Mexico. Table 2-I contains a summary of available information on earthquake damage to water systems for the period 1818 through 1985. It should be noted that the amount of damage in Mexico City has generally increased with the increasing size of the city which is in figure 2-1. Note historically that the northern portions of the Federal District have been the most heavily populated.

Of engineering importance is the fact that during the 1973 Orizaba earthquake, the main aqueduct (buried transmission line) supplying water to the city of Cordoba was severely damaged at a minimum of 20 points along its length. The aqueduct was a 36"φ reinforced concrete pipeline with 'lock joint' type joints. During this earthquake, all of the pipeline failures occurred at the joints.

The 1979 Guerrero earthquake damaged a 72"φ buried reinforced concrete aqueduct at 10 locations along its 6 kilometer length in southeast Mexico City. Figures 2-2 and 2-3 show typical damage. Pipeline failures were mainly the result of tension and/or compression at joints. In order of incidence, the failures were due to compressional crushing at the bells, pull out accompanied in some instances by rotation at the joints. An evaluation of the damage indicates that the failures were due to a lack of flexibility in the system as opposed to a lack of strength, [1] and [2]. The repair method used consisted of either replacing the broken pipes or repairing the joints with a bolted steel collar. Unfortunately neither of these procedures improve the deformation characteristic (ie, flexibility) of the pipeline joints. Replacing the broken pipes theoretically returns the system to its pre-earthquake

condition, hence leaving it vulnerable to future seismic damage. Repairing with a bolted steel collar has the effect of marginally reducing the overall flexibility of the system as a whole, and does not prevent damage at adjacent joints during future earthquakes.

The above discussion is not meant to question the engineering judgement of Mexican officials after the 1979 Guerrero earthquake, but to highlight the difficulty of increasing seismic resistance (flexibility) for an existing linear system with thousands of 'weak link' joints.

TABLE 2-I Historic Earthquake Damage To Water Systems In Mexico, [3]

Date	Earthquake Magnitude	Water System Damage
May 31, 1818	*	Broken arches in aqueducts in Mexico City.
May 4, 1820	*	Damage to above ground aqueducts in Mexico City.
January 6, 1835	*	Damage to above ground aqueducts in Mexico City.
October 3, 1864	*	Damage to buried clay pipes in Mexico City.
July 19, 1882	*	Damage to buried clay pipes in Mexico City.
April 14, 1907	8.2	Damage to buried clay pipes in Mexico City.
June 3, 1932	8.4	Extensive damage to buried pipelines in Mexico City.
June 30, 1973	7.5	Damage to buried aqueducts in the cities of Orizaba and Cordoba.
March 14, 1979	7.6	Damage to a main buried aqueduct in Mexico City.
September 19, 1985	8.1	Extensive damage to buried pipelines and buried aqueducts in Mexico City.

* Not available

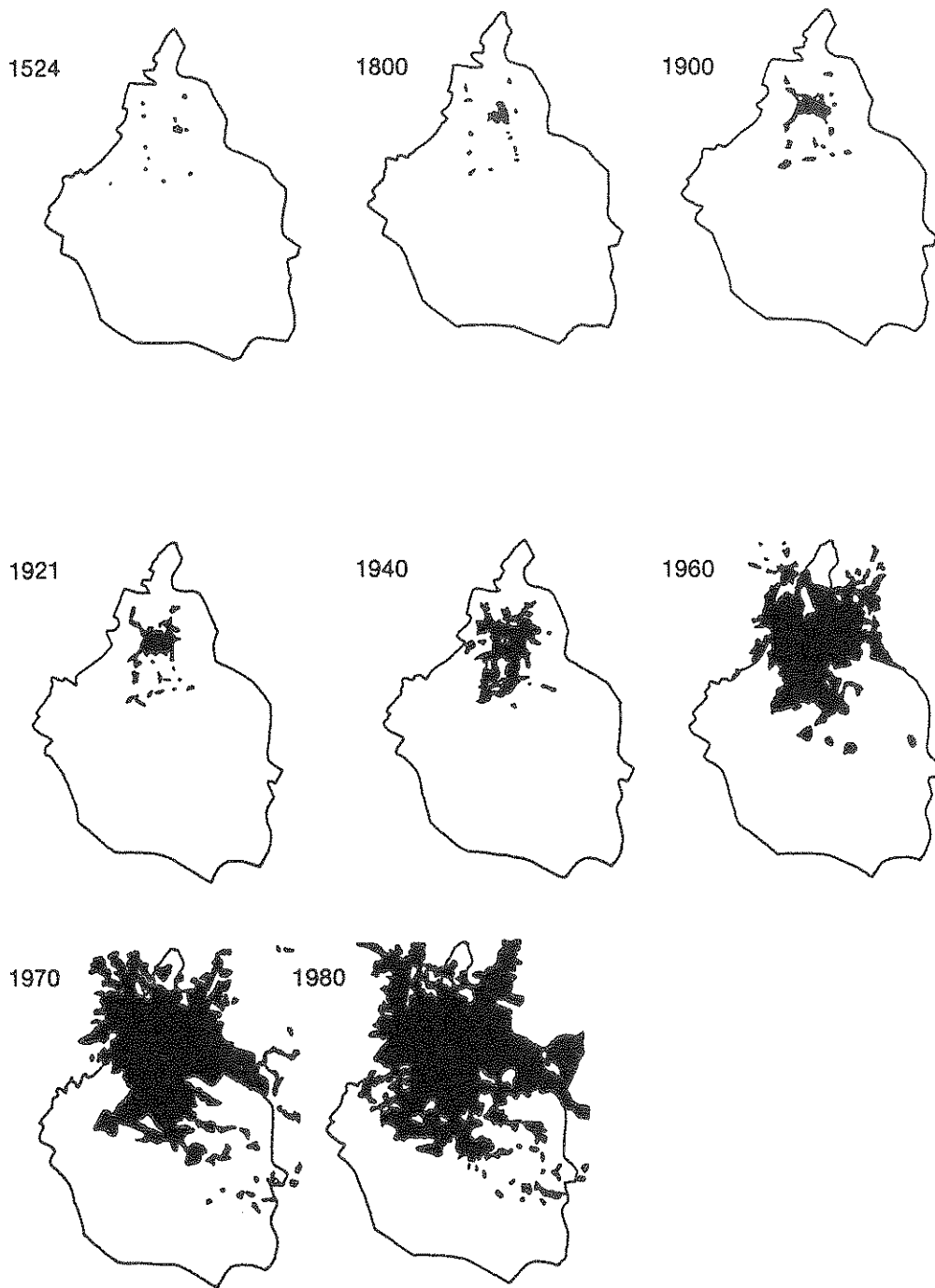

FIGURE 2-1 Growth Of Metropolitan Mexico City 1524-1980



FIGURE 2-2 Aqueduct Damage During 1979 Guerrero Earthquake

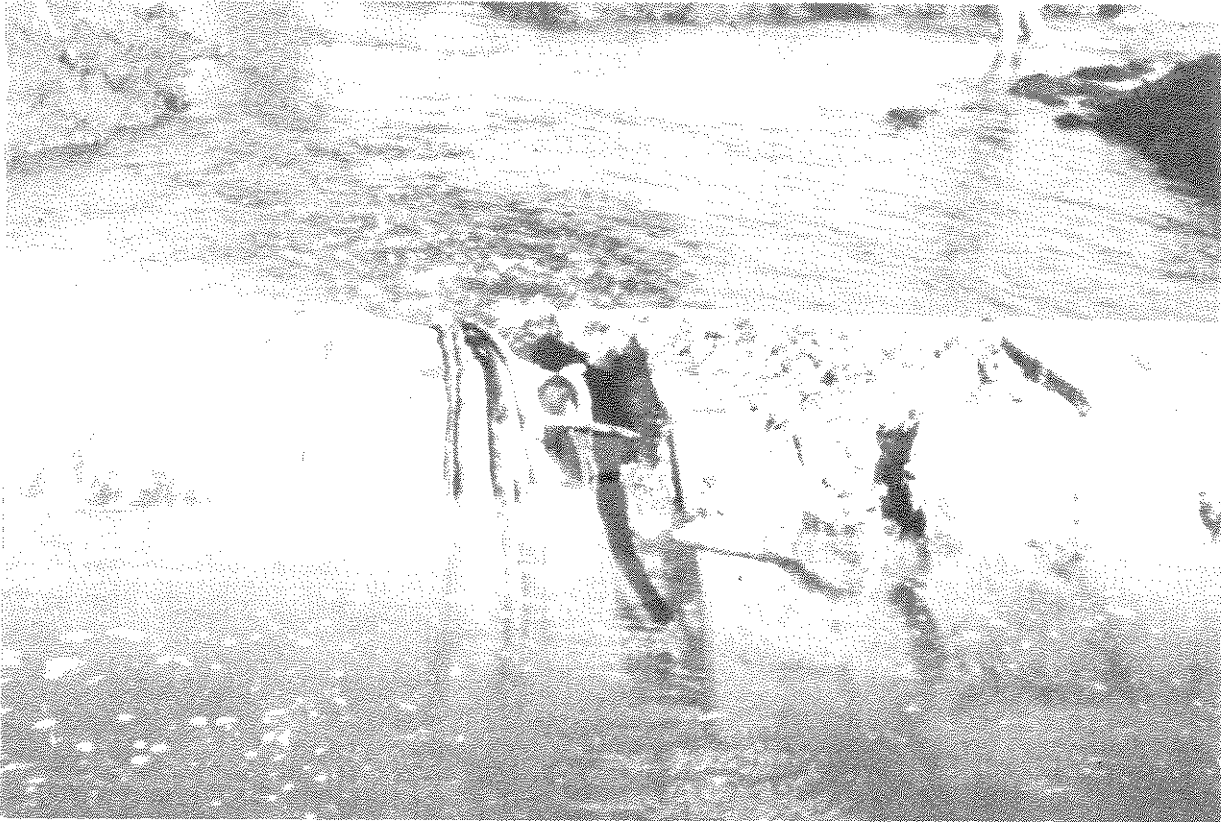

FIGURE 2-3 Aqueduct Damage During 1979 Guerrero Earthquake

SECTION 3
METROPOLITAN MEXICO CITY WATER SUPPLY SYSTEM

In this section, relevant information about the water systems of Metropolitan Mexico City is presented. The water distribution and waste water systems controlled by the Federal District as well as those controlled by the State of Mexico are described.

Mexico City, the largest city in the world, was founded by the Aztecs in 1325 in a close watershed known as the Valley of Mexico. Since the foundation of the city, then known as the Great Tenochtitlan, the characteristics of the valley caused water related problems to inhabitants. Complicated water supply and sewage systems were constructed to overcome these problems.

Metropolitan Mexico City presently covers an approximate surface area of 1500 km² with a population that exceeds 18 million people [4]. The city is administratively divided in two parts. The larger part is located in the Federal District (D.F.) while the remaining part is located in the neighboring State of Mexico (E. de M). The D.F. is provided with a flow of 62m³ /sec and the metropolitan areas of the E. de M. with a somewhat smaller flow.

3.1 Federal District

The supply sources and the percentage of the total supply for the Federal District are given below:

Springs and Wells (D.F. and C.A.V.M.)	71.0%
Lerma System (D.F.)	14.5%
Cutzamala System	9.7%
Recycled Sewer Water	3.2%
Retained Rainfall	1.6%

The Ministry of Agriculture and Water Resources (SARH) through its Water Commission for the State of Mexico (CAVM), provides 20 m³/sec of the total flow of 62 m³/sec into the D.F.

A map showing the supply sources is presented in figure 3-1. The Federal

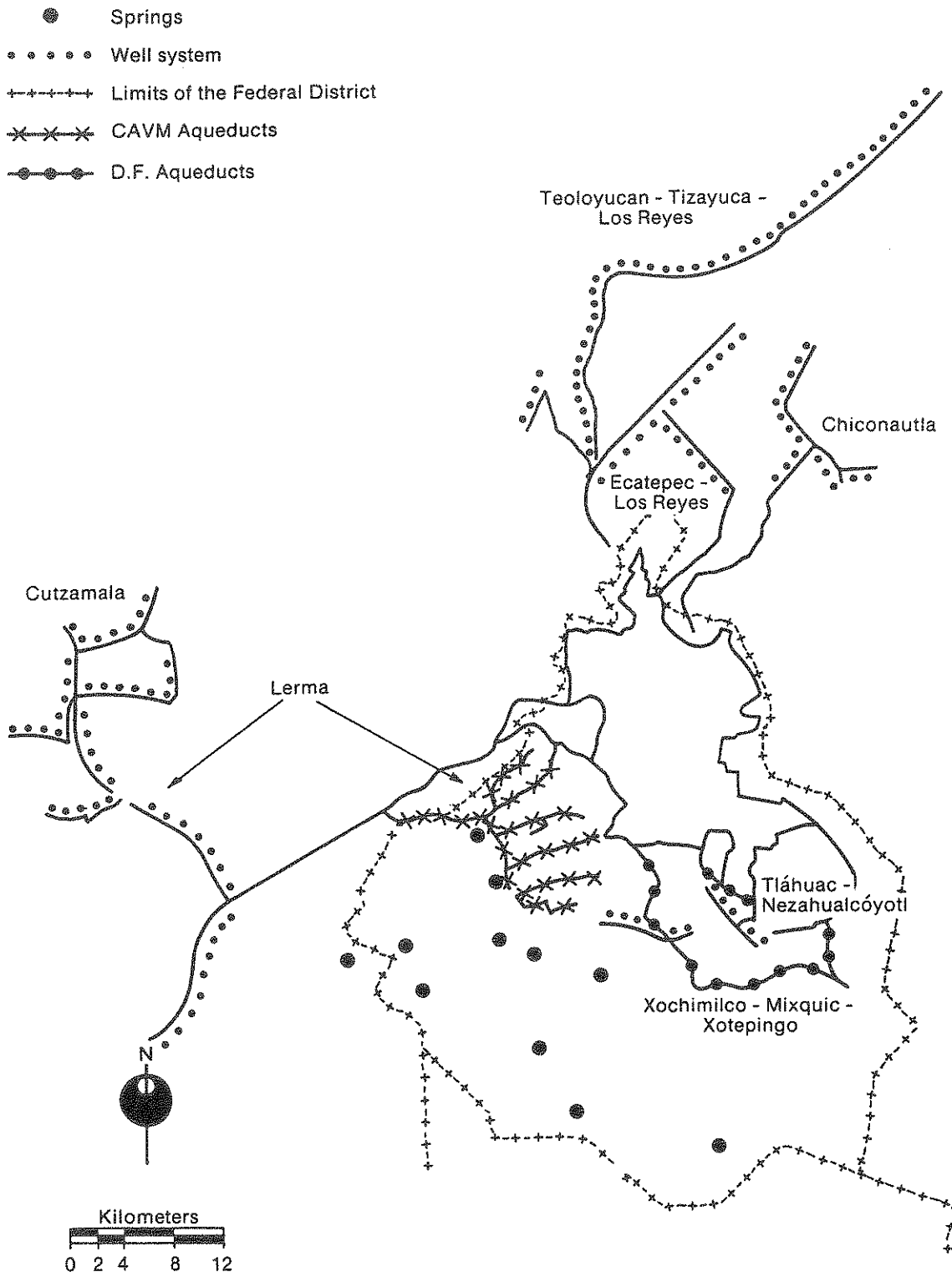

FIGURE 3-1 Water Supply For Metropolitan Mexico City

District government operates all the wells located within the District as well as the Lerma System which is located west of the Valley of Mexico in the State of Mexico. The Lerma system contains over 200 wells which supply Metropolitan Mexico City as well as town and irrigation demands in the area. Due to the latent overdraft of the aquifers in both the valleys of Mexico and Lerma, the federal government has begun operation of the Cutzamala system that supplies water to Metropolitan Mexico City from the Balsas River basin to the west of the Valley of Mexico. It is estimated that this system will satisfy the increased demand to the year 2000.

There are ten waste water treatment plants operated by the D.F. which provide recycled water for industrial use, recreation lakes and park watering. This 500 km treated waste water network is shown in figure 3-2.

In addition there are a number of reservoir systems on the eastern slopes of the Valley of Mexico built to prevent flooding during the rainy season. This retained rainfall is also used for water supply for the city.

The primary distribution and transmission network in the D.F. consists of about 560 km of pipelines with diameters ranging from 20" to 72". The secondary distribution network is composed of about 11,700 km of pipe with diameters ranging from 2" to 18". The system has evolved from the beginning of the century with part of the network as old as 8 decades and with many new lines having just been constructed. A complete census of the material and type of pipe as well as the precise location of some of the lines is no longer available. This is due to the fact that the headquarters building, where this information was kept, was completely destroyed by the September 1985 earthquake. Figure 3-3 shows the location of the most important primary distribution and transmission lines with diameters 20" and above. Note that these primary lines are fairly uniformly distributed in the northern part of the Federal District which is urbanized. The southern part of the Federal District is mountainous and sparsely populated.

Waste water and urban runoff are collected by a 12,000 km sewer network discharging to a 1176 km collector system. The diameters in the sewer system vary from 12" to 16" and in the collector system from 24" to 98". As with the primary water supply piping, the sewer collector system is uniformly

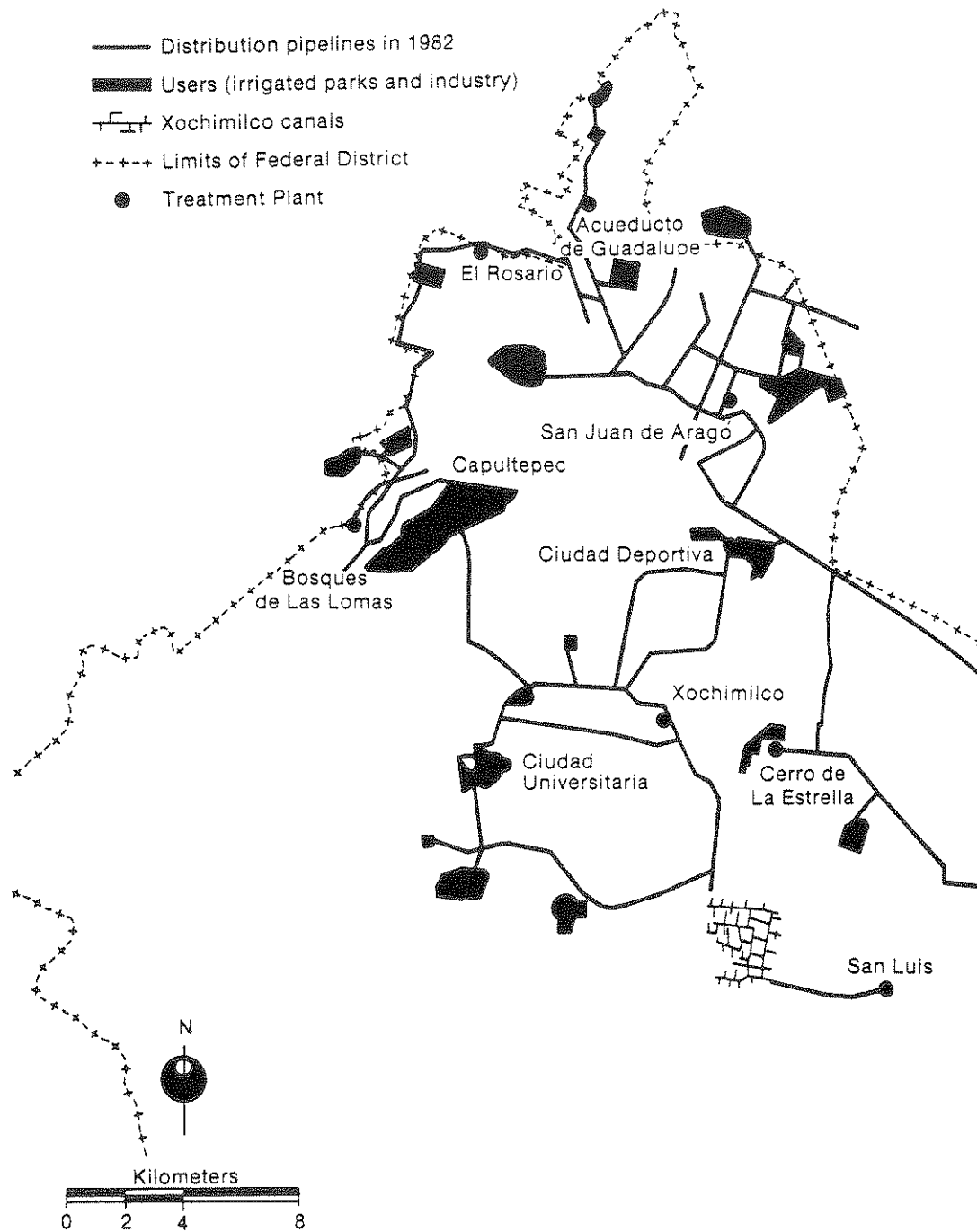

FIGURE 3-2 Recycled Waste Water Distribution Network

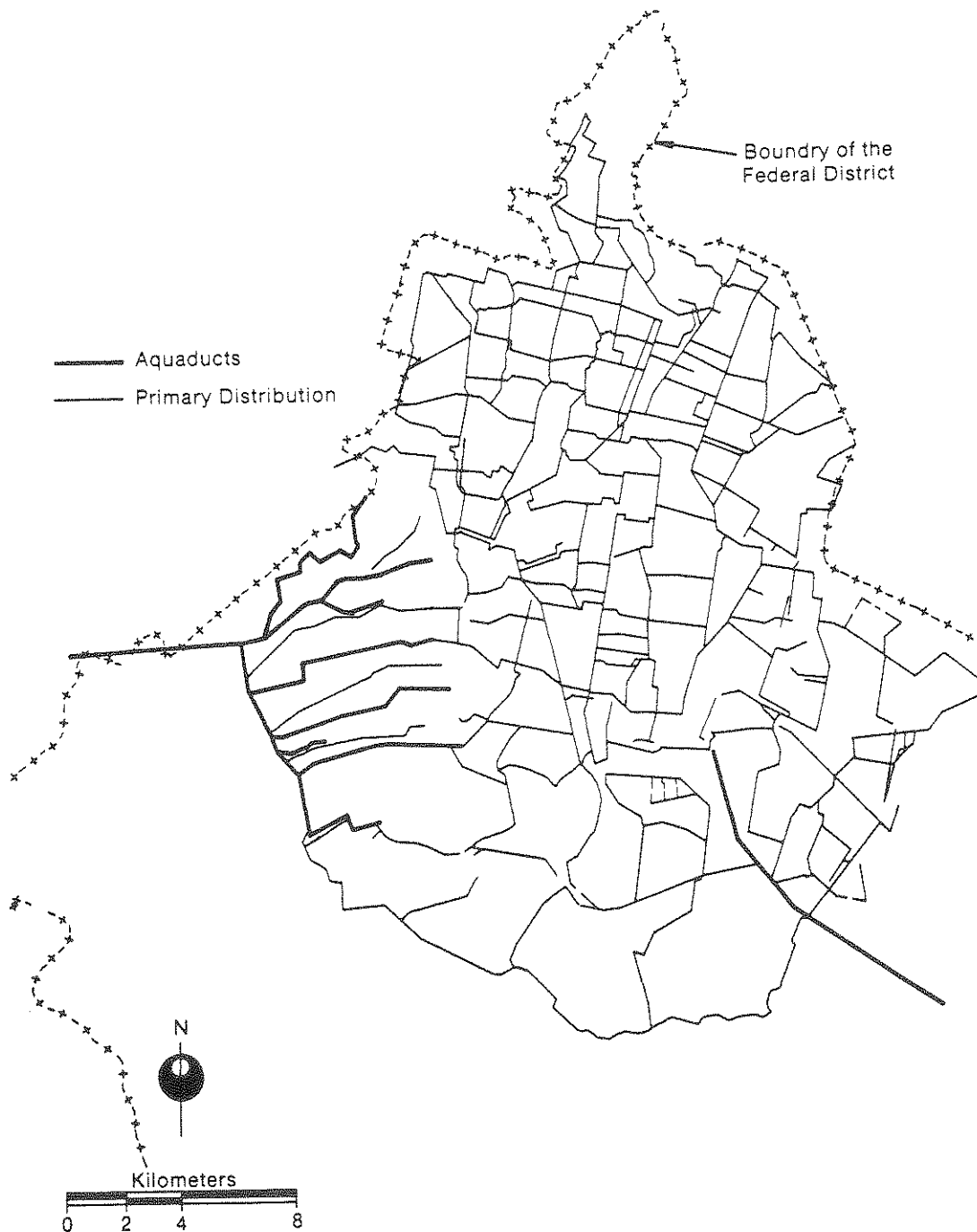

FIGURE 3-3 Aqueducts And Primary Distribution Lines Controlled By The Federal District

distributed in the northern (urbanized) portion of the D.F. The main lines of the collector system discharge into three large lines; the Gran Canal which is open, and two large tunnels at depth (200" to 250" diameter) known as 'Emisor Oriente' and 'Emisor Central' respectively.

3.2 State of Mexico

Regarding the parts of metropolitan area located in the State of Mexico, extensive damage to the water distribution system occurred at two different location known as 'Ciudad Nezahualcoyotl' and ' Municipio de Ecatepec'. These systems were built during the 1970's with well constructed asbestos cement pipes.

Figure 3-4 shows the water system of 'Ciudad Nezahualcoyotl'. The total length of the system is approximately 900 km. The distribution network is supplied by 25 deep wells pumping into the system. A main aqueduct, discussed in Section 7, comes from the 'Caldera' tank. This 9 km long main aqueduct is a 42"φ welded steel pipeline.

The water distribution network for the Municipio de Ecatepec is approximately 300 km long and is shown in figure 3-5. Except for the absence of the welded steel aqueduct, its characteristics are similar to those in Ciudad Nezchualcoyotl.

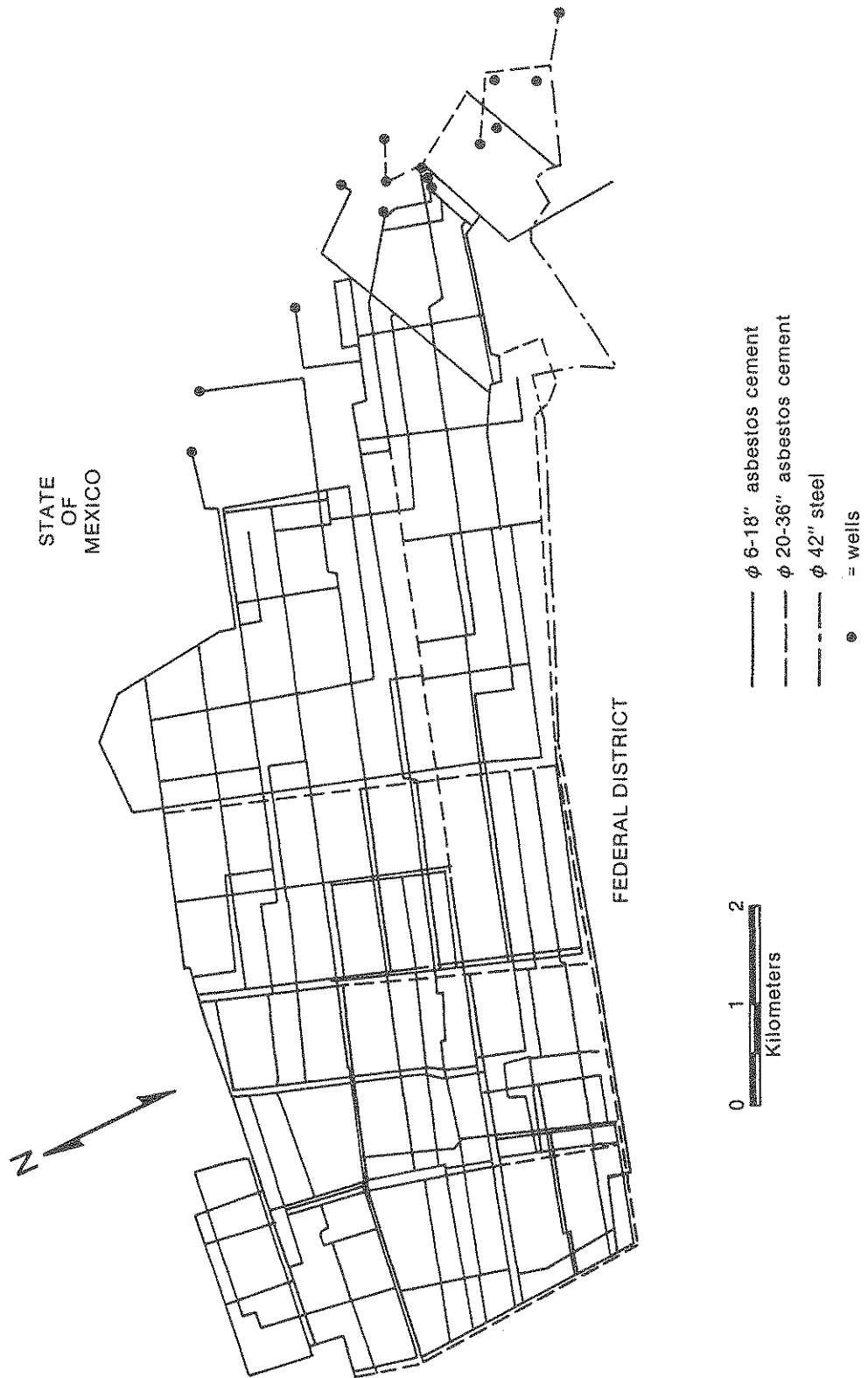

FIGURE 3-4 Water Distribution System In Ciudad Nezahualcoyotl (E.de.M.)

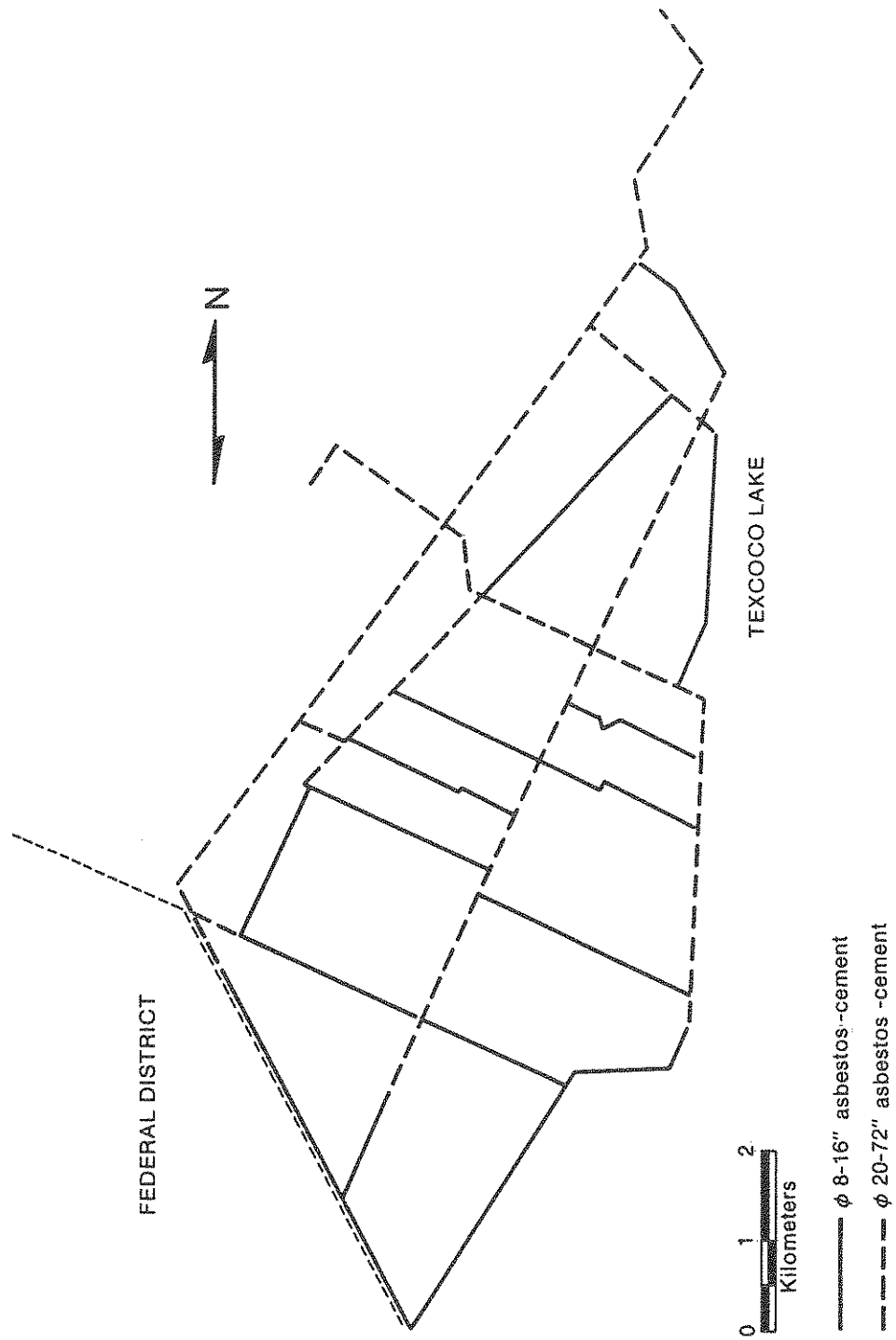

FIGURE 3-5 Water Distribution System In Municipio De Ecatepec (E.de.M.)

SECTION 4
WATER SERVICE DISRUPTION DUE TO THE 1985 MICHOACAN EARTHQUAKE

In this section, the water service disruption and its impact on the population of metropolitan area are discussed. The main causes for the disruption are identified. Repair methods and techniques used by government officials to supply water during the recovery period are also described.

Conservative estimates are that the earthquake left 3 to 3.5 million people without water in the Federal District while 1.8 million people were without water in the State of Mexico. That is, approximately 30% of the estimated 18 million people in Metropolitan Mexico City were without water immediately after the earthquake. The lack of water for this large portion of the population was caused by extensive damage to the buried transmission and distribution lines in Metropolitan Mexico City. There was some minor damage to wells, but reservoirs, storage facilities, and purification plants were essentially unaffected by this earthquake. The success of government officials in implementing an emergency response plan, which had never previously been into practice, is noteworthy.

4.1 Federal District

Prior to the 1985 event, aqueducts in the southeastern portion of the city provided a flow of about $7.6 \text{ m}^3/\text{sec}$ to the Federal District distribution network. The Michoacan earthquake severely damaged these aqueducts. This resulted in temporary suspension of the $7.6 \text{ m}^3/\text{sec}$ flow to the distribution network. The distribution network itself also experienced numerous earthquake induced leaks that resulted in a lack of water in some areas of the city. In addition, non-earthquake damage to the distribution system occurred when people broke open valve boxes to extract water which remained in the system.

The implementation of the Federal District water system emergency response plan was delayed because the central headquarters building was completely destroyed by the earthquake. As a result, organization of emergency supply and repair activities was very difficult. Nevertheless the response of government officials was extremely fast, considering the circumstances, with

the damage assessment of the system starting within a few hours after the occurrence of the earthquake.

As soon as the areas without water were identified, limited distribution using water tank trucks, as shown in figure 4-1, and portable tanks provided by the U.S. Government was started. Furthermore the Federal Government provided an extra $1.73 \text{ m}^3/\text{sec}$ to the Federal District network to compensate for the supply shortage. Initially repair activities concentrated on the damaged aqueducts and on the main lines in the distribution system. As of October 2, 1985 (ie, about 2 weeks after the earthquake) the outage in the Federal District is as shown in figure 4-2. The 'colonias' (neighborhoods) without water were those listed in table 4-I. By the end of October the aqueduct supply had been restored to about $7.1 \text{ m}^3/\text{sec}$ so that the water supply to the distribution network was essentially the same as before the earthquake. Repairs in the distribution network lasted a few months.

4.2 State of Mexico

In the State of Mexico, a major transmission pipeline supplying about $1.6 \text{ m}^3/\text{sec}$ was severely damaged. This particular pipeline is discussed in more detail in Section 7. The flow supplied by this pipeline represented 70% of the total in Ciudad Nezahualcoyotl, the other 30% being supplied by wells connected to the distribution network. As in the Federal District, damage to the distribution network was also extensive. State of Mexico officials initiated the emergency plan immediately after the earthquake. The system was restored to its pre-earthquake condition by November 4. As in the Federal District, repair covered earthquake induced damage as well as numerous valve boxes which were broken by desperate users. During the recovery period, water was distributed using tank trucks, portable tanks and sealed plastic bags with purified water, as shown in figure 4.3.

4.3 Repair Techniques

The priority order for earthquake repairs (i.e., which leaks were repaired first) was based upon a combination of engineering and political judgment. That is, some leaks were temporarily left unrepaired since they were able to provide reduced water service to downstream portions of the system.

FEDERAL DISTRICT

BENITO JUAREZ

NARVARTE
ALAMOS

XOCHIMILCO

STA. CRUZ ACALPIXCA
U. VILLA XOCHIMILCO
SAN GREGORIO

TLAHUAC

SELENE
STA. CECILIA
AMPL. SELENE
STA. CATARINA
SAN JOSE
DEL MAR
TLALTENCO
SUR TLALTENCO
OJO DE AGUA
TRIANGULO

CUAUHTEMOC

CENTRO
ALGARIN
ASTURIAS
MORELOS
DOCTORES
ROMA NORTE Y SUR
OBRERA
PAULINO NAVARRO
LAGUNILLA

IZTAPALAPA

COLONIAL IZTAPALAPA
ZONA URBANA EJIDAL
U.H. VICENTE GUERRERO
JUAN ESCUTIA
TEPALCATES
U.H. LA VALENCIANA
EJIDOS DEL MORAL
U.H. GUELATAO DE JUAREZ
LA PENIA STA. CRUZ
SIFON STA. CRUZ MEYEHUALCO
LOMAS DE ZARAGOZA
SAN ANDRES TETEPILCO
STA. MA. AZTAHUACAN
PROGRESISTAS
U.H. MARGARITA MAZA DE JUAREZ
VOCEADORES
FRANCISCO VILLA

IZTACALCO

VIADUCTO PIEDAD
PANTITLAN
MARTE
SAN PEDRO IZTAPALAPA
GRANJAS MEXICO
REFORMA IZTACCIHUATL
AGRICOLA ORIENTAL
JUVENTINO ROSAS
RAMOS MILLAN
LOS REYES
SANTA ANITA.

VENUSTIANO CARRANZA

IGNACIO ZARAGOZA
U. GOMEZ FARIAS
JARDIN BALBUENA
FEDERAL EMILIO CARRANZA
MERCED BALBUENA
MAZA ROMERO RUBIO
U.H. KENNEDY
U. GOMEZ
SEVILLA
PENSADOR MEXICANO
FELIPE PESCADOR
ALVARO OBREGON
LORENZO BOTURINI
MAGDALENA MIXUCA

GUSTAVO A. MADERO

Sections 4th, 5th and 6th
SAN JUAN DE ARAGON
VILLA DE ARAGON
S.T.M. SAN JUAN DE ARAGON
SAN PEDRO EL CHICO
CAMPESTRE ARAGON
U. HABITACIONAL LA JOYA
NUEVA ATZACOALCO
7 DE NOVIEMBRE
PUEBLO DE SAN JUAN DE
MALINCHE
SAN BARTOLO ATEPEHUACAN

STATE OF MEXICO

CIUDAD NEZAHUALCOYOTL (all 'colonias')

MUNICIPIO DE ECATEPEC

Table 4-I 'Colonias' in Metropolitan Mexico City Without Water Supply as of October 2, 1985.

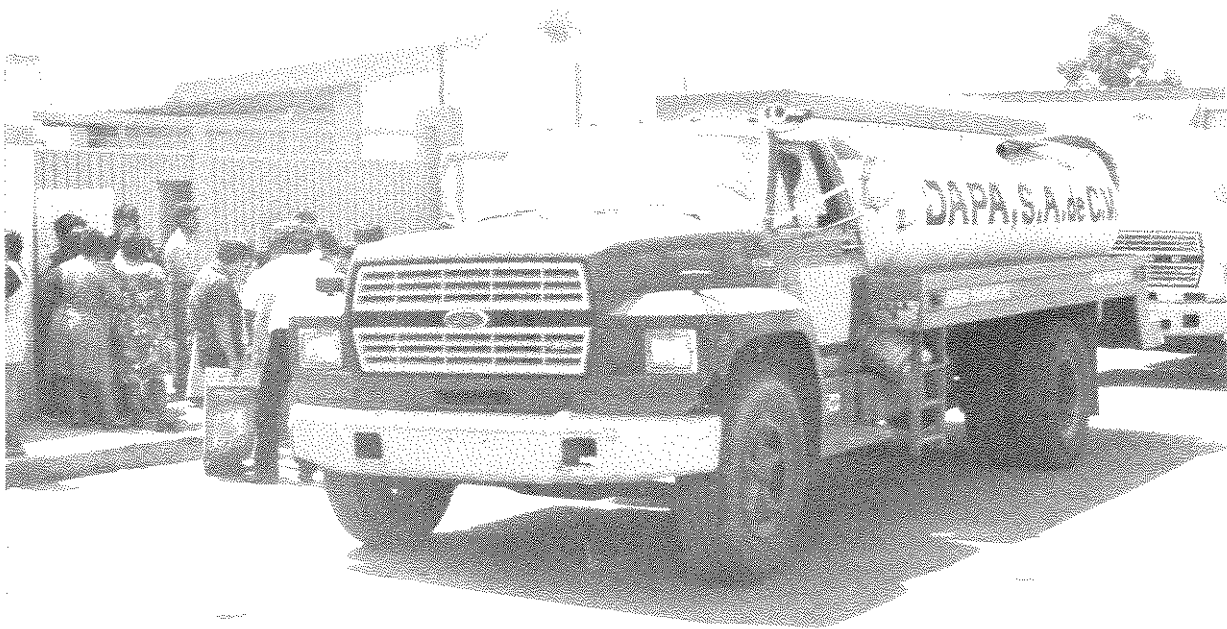

FIGURE 4-1 Water Tank Truck Distributing Water To Affected Population

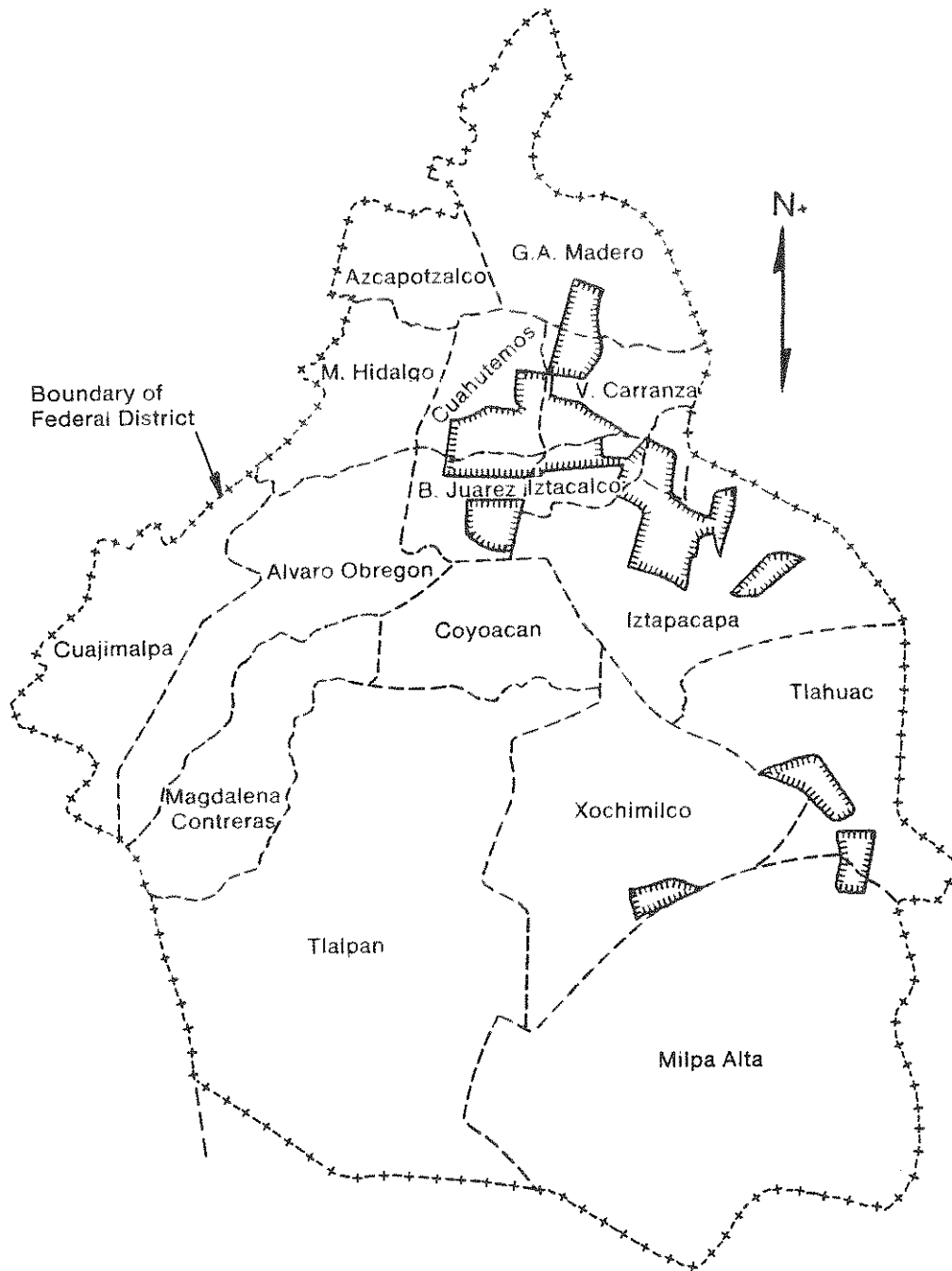

FIGURE 4-2 Water Service Disruption In Federal District As Of October 2, 1985



FIGURE 4-3 Distribution Of Sealed Plastic Bags With Purified Water

Locations of damage generally were indicated by the presence of water at the ground surface. It was not unusual for damage at a downstream location to become evident only after an upstream location was repaired and the line repressurized. Valves were closed to isolate the damaged portion. The ground was excavated and braced, if necessary, and the excavation was dewatered. In some instances, the closest valve to the break was found to be inoperable, which increased the length of the isolated portion and, hence, the time required to dewater the excavation.

The techniques used to repair the seismic damage were essentially the same as the repair techniques used in normal operating circumstances. Repair clamps, repair sleeves or fabricated steel saddles were installed around damaged joints. For large diameter piping, the two half-cylinder saddle segments were bolted together with the axis of the bolts being parallel to the longitudinal axis of the pipeline as shown in figure 4.4.

Mexico City was fortunate in the sense that facilities capable of fabricating the repair saddles were located in the city. If the damage had occurred in more remote areas of the country or if these repair items were only available from foreign sources, the delay time associated with repair item availability would likely have been substantially longer. The authors understand that few if any repair items had been stockpiled in Mexico City specifically for earthquake repairs. That is, only repair items typically needed for normal operating conditions were available.

As mentioned previously, repair and restoration of the water system was hindered by substantial structural damage to some of the water system buildings. The loss of records, maps, etc., as well as the time required to establish alternate headquarters resulted in some delays.

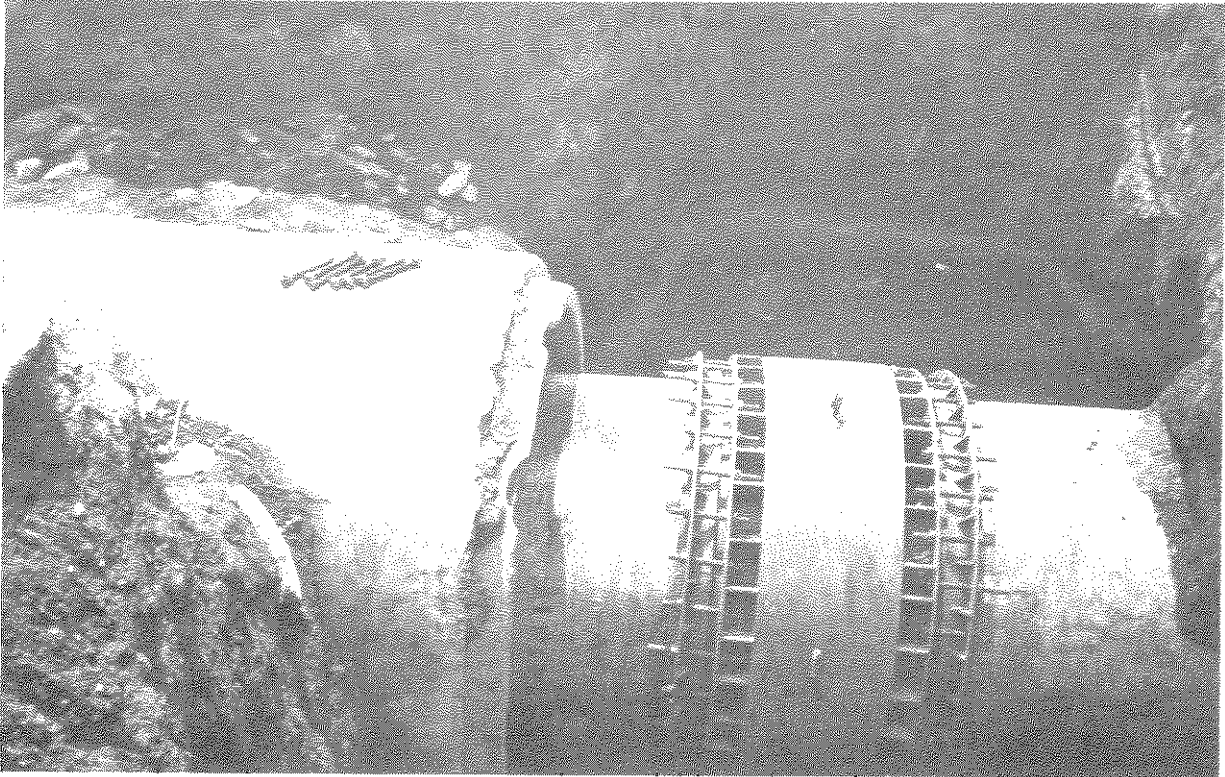

FIGURE 4-4 Steel Saddle On Damaged Pipe

SECTION 5
SUBSOIL CONDITIONS IN METROPOLITAN MEXICO CITY AND CHARACTERISTICS OF
THE 1985 MICHOACAN EARTHQUAKE

In this section, geological and soil information for the Mexico City region is presented. Specifically, soil types as well as soil zonation for the metropolitan area are described. Information about subsoil topography (i.e. depth of hard deposits) as well as the distribution of site response periods are also presented. Finally, characteristics of the 1985 Michoacan earthquake of interest to lifeline earthquake engineers are discussed.

5.1 Subsoil Conditions

Metropolitan Mexico City is located in a closed basin surrounded by mountains of volcanic origin. Through geological time, the basin became a lake where volcanic ashes were deposited and decomposed into a lacustive clay. This lake eventually dried exposing lake bed soils of unusual mechanical characteristics well recognized in the soil mechanics literature. Detailed characteristics of the different geological materials found in the area are presented by Marsal [5] and Margal and Mazari, [6]. However, for engineering purposes, subsoil conditions in the valley have been grouped in three zones as shown in figure 5-1. These zones are;

- a. The Hill Zone; located in the hilly areas around the bed lake and formed basically of volcanic rocks, dense sand and silts.
- b. The Transition Zone; located between the Hill and Lake Zones and formed of a shallow layer of clay founded on volcanic rock formations dipping toward the center of the lake.
- c. The Lake Zone; located in the lakebed and consisting primarily of soft lacustrine clays, with some clayey siltly sands and medium dense clayey sands all of alluvial origin. Typical stratigraphy in this zone is shown in figure 5-2 which was developed from borehole data. The profiles are along sections AA and BB of figure 5-1.

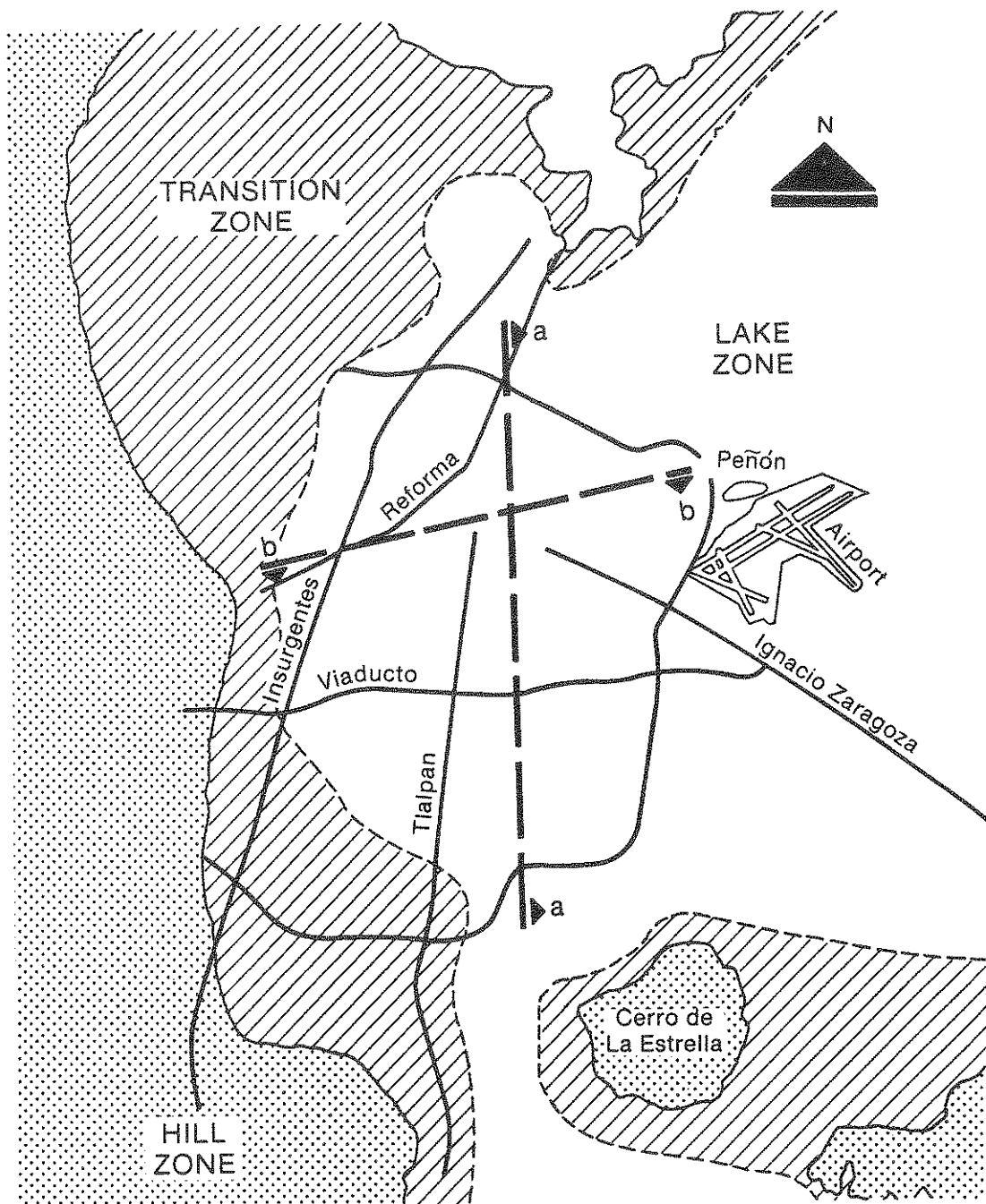
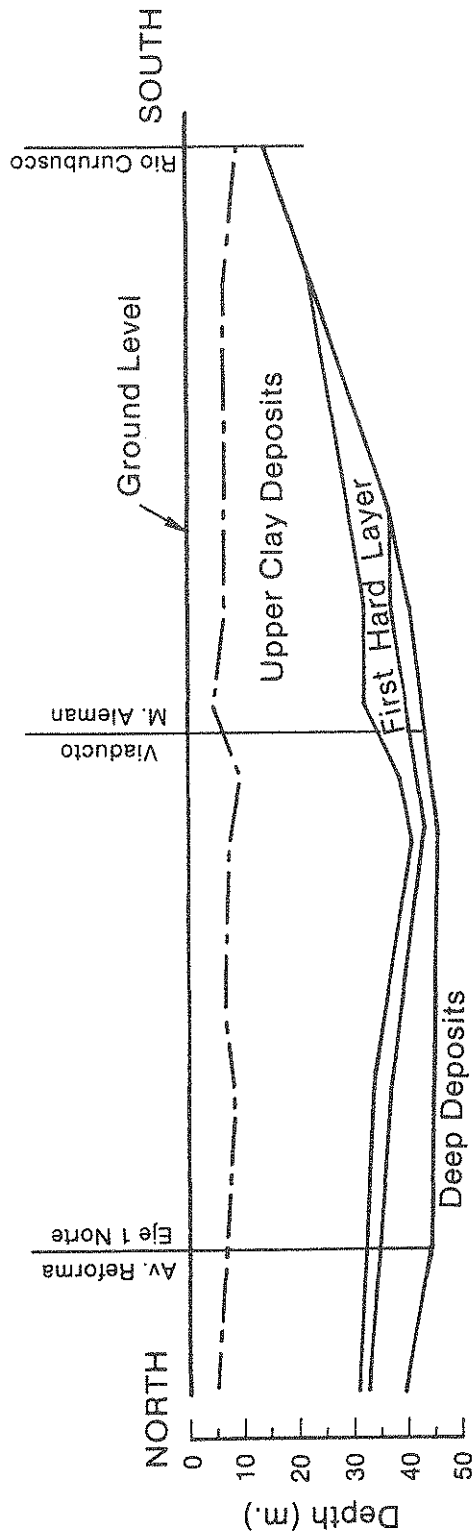
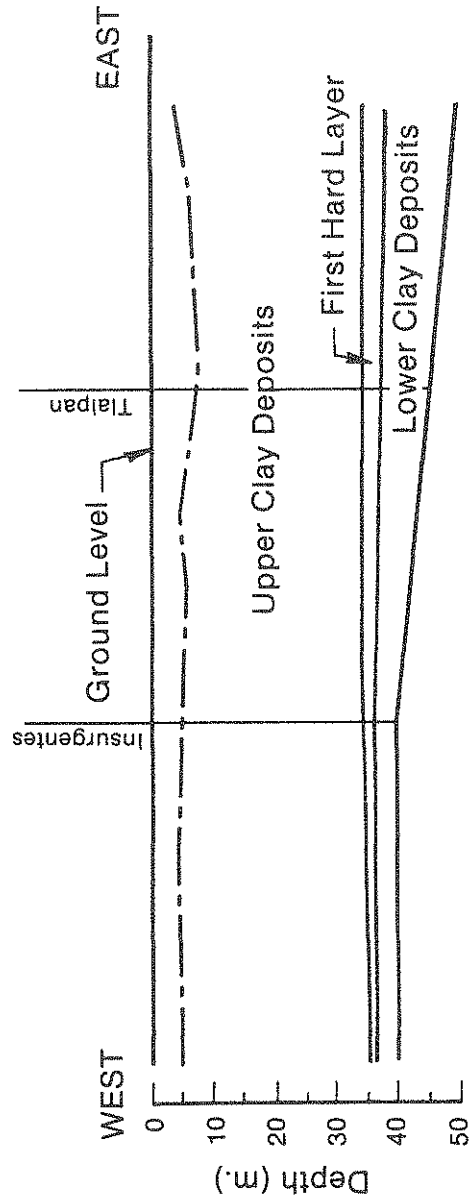

FIGURE 5-1 Soil Zones For Metropolitan Mexico City



a) Profile along North-South Line a-a



b) Profile along East-West Line b-b

FIGURE 5-2 Soil Profiles For Metropolitan Mexico City

Figure 5-3 depicts the lines of equal depth in meters to the deep deposits. After the September 1985 earthquake, an extensive soil exploration program coupled with microtremor measurements was initiated, [7]. Figure 5-4 shows lines of equal site response period. As one would expect, there is a tendency for deeper sites to have longer periods. However when figures 5-3 and 5-4 are compared there is a lack of a one to one correlation between site period and depth to the deep deposits. As will be discussed in Section 6, most of the distribution pipeline damage occurred in the Lake Zone particularly at locations with site response period of two seconds or larger and with depths to the deep deposit of 30m to 70m. Seismic damage to aqueducts (large diameter transmission mains) occurred only in 'delegaciones' Thahuac and Xochimilco which are located in the southeast part of the city. This part of the city is in the Transition and Lake Zones south of the Cerro de la Estralla (Hill of the Star) and the Cerro de Sta. Catarina (Hill of St. Catarina) and is not heavily urbanized. Local soil conditions along the main main aqueducts in the southeastern part of the city have been reconstructed from available sources [8]. It was observed that the near surface shear wave velocities range from 30 to 50 m/sec in the Lake Zone and were typically about 100 m/sec in the transition zone.

5.2 Characteristics of the Earthquake Motions

The Michoacan Earthquake of September 19, 1985, one of the most destructive in this century, originated about 400 km southwest of Mexico City as shown in figure 5-6. The earthquake was generated at a depth of about 18 km in a subduction zone where the Cocos Plate subducts the North American Plate, as shown in figure 5-7. It consisted of two subevents, with the second initiating about 26 seconds after the first.

The epicentral area had been widely recognized as one with a high probability of earthquake occurrence. As a result, the instrumental information was extensive with numerous records in the epicentral area as well as at different locations in the Valley of Mexico.

In the Valley of Mexico (ie, Metropolitan Mexico City), the recorded ground motions are considered to be fairly unusual due to long period

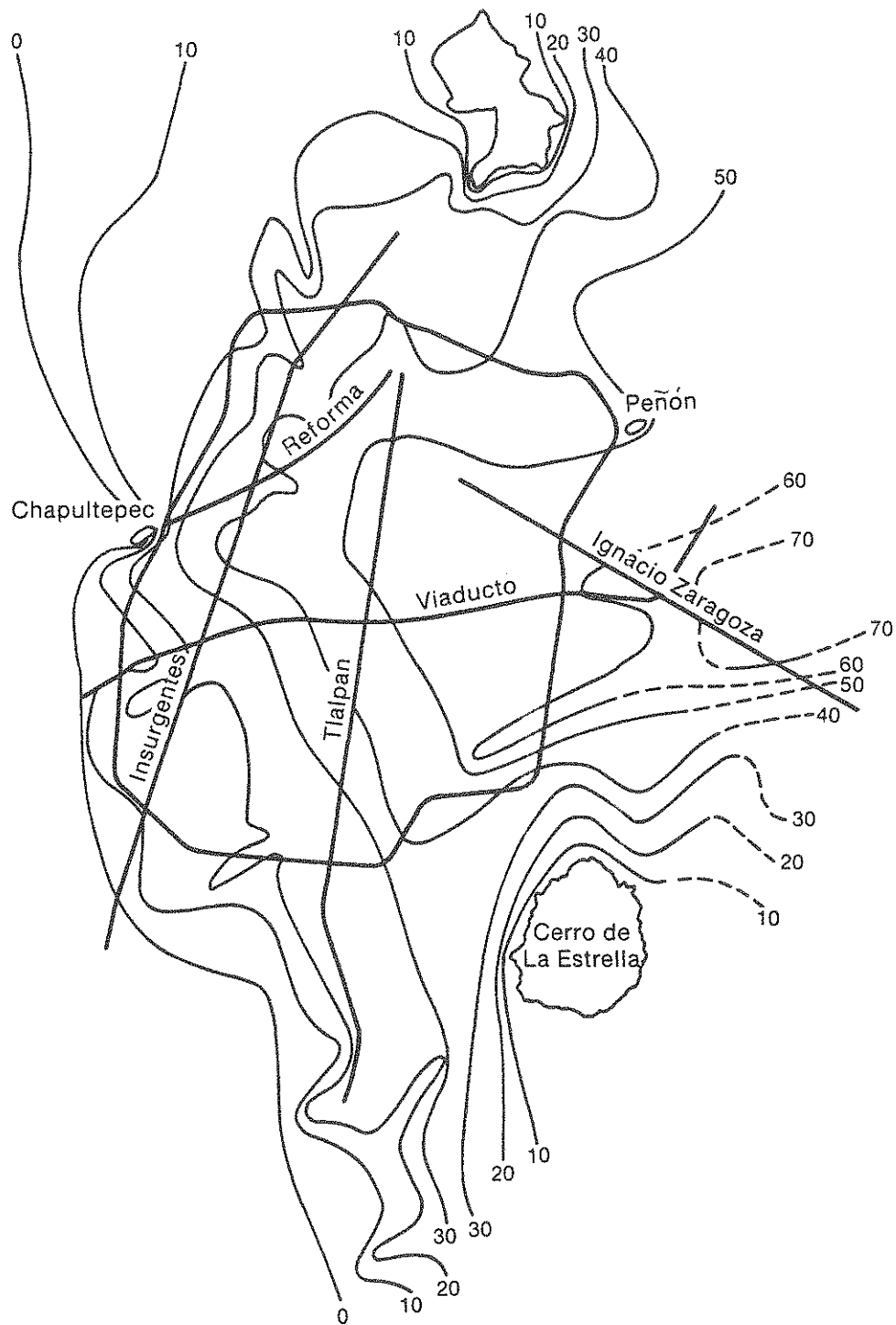

FIGURE 5-3 Lines Of Equal Depth To Deep Deposits (In Meters)

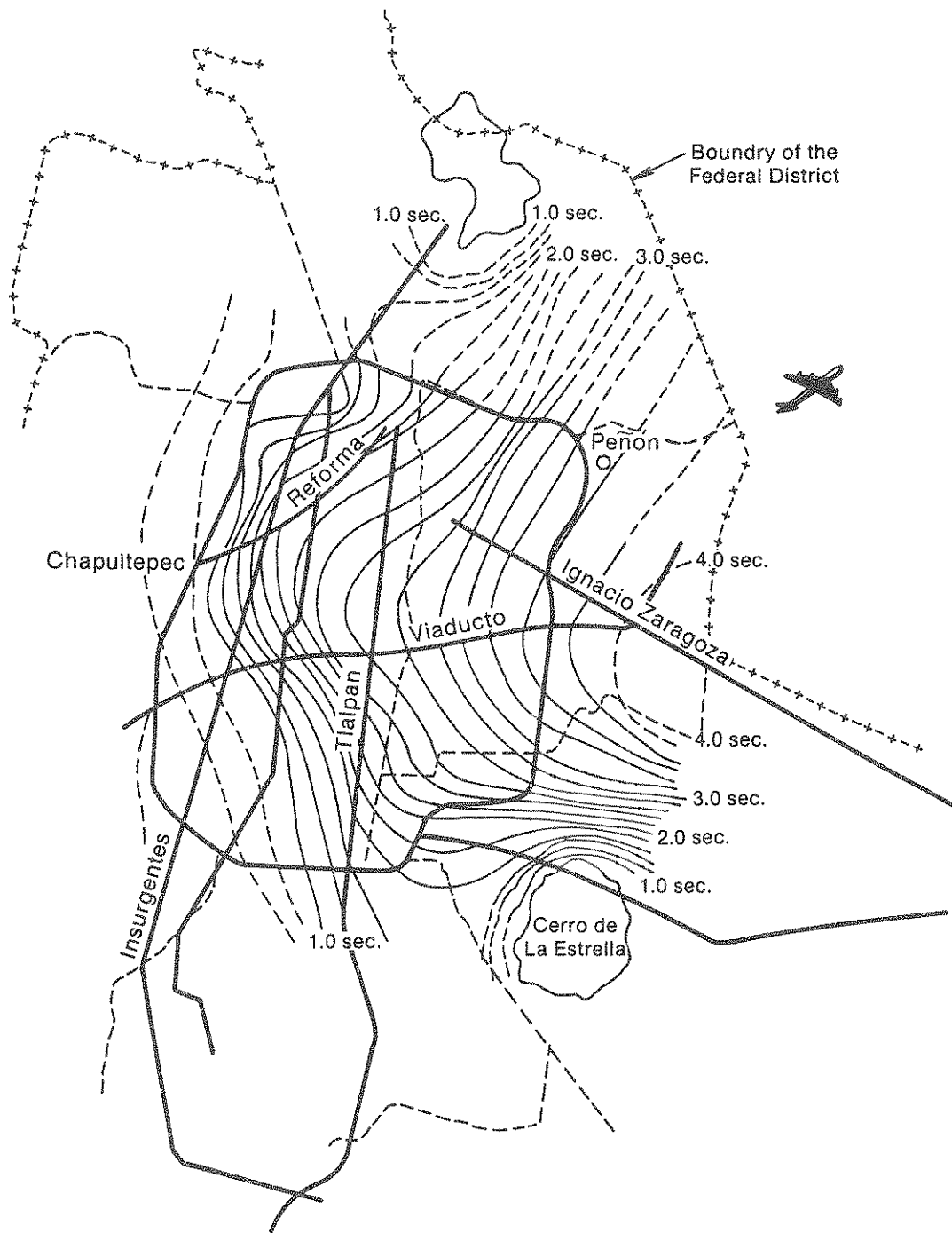

FIGURE 5-4 Lines Of Equal Site Response Period (In Seconds)

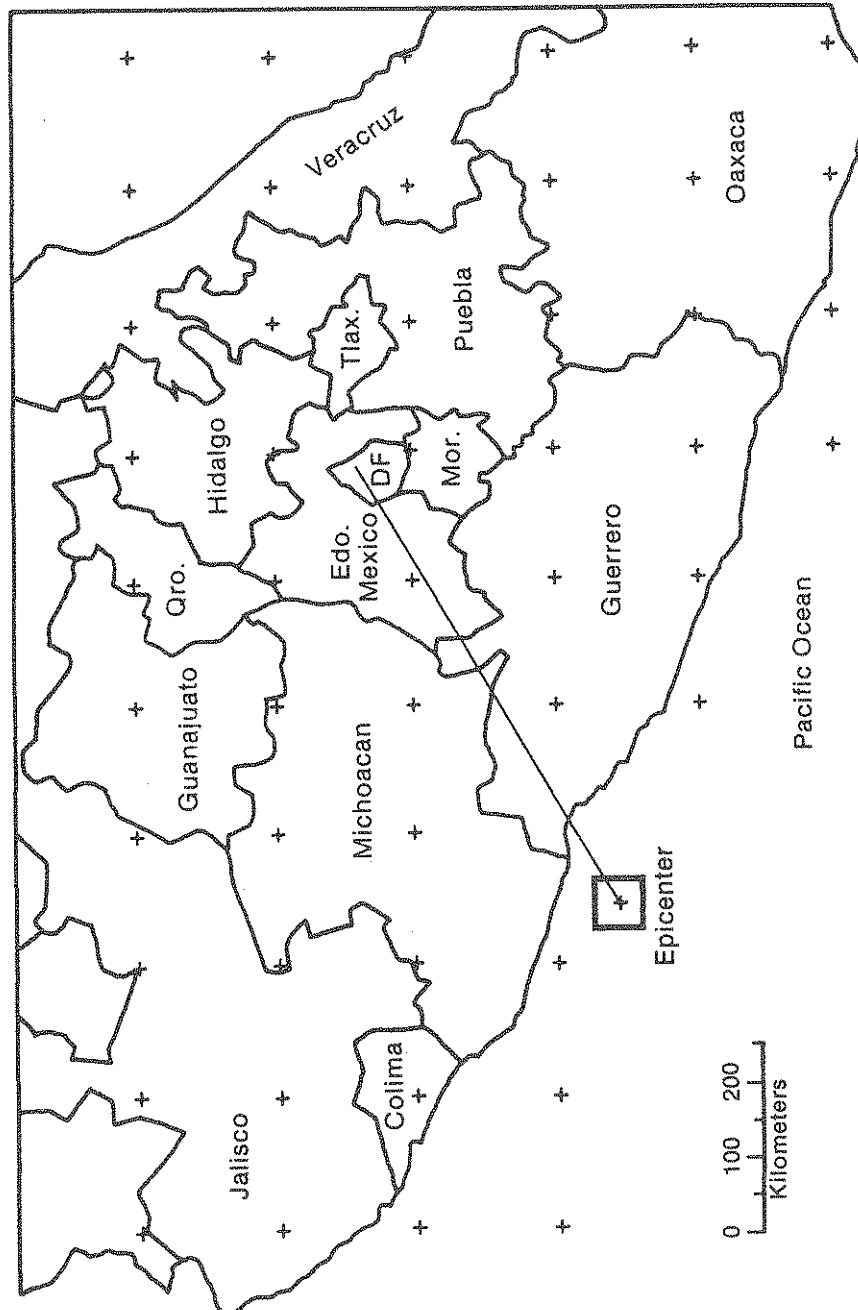

FIGURE 5-5 Epicenter Location For Michoacan Earthquake

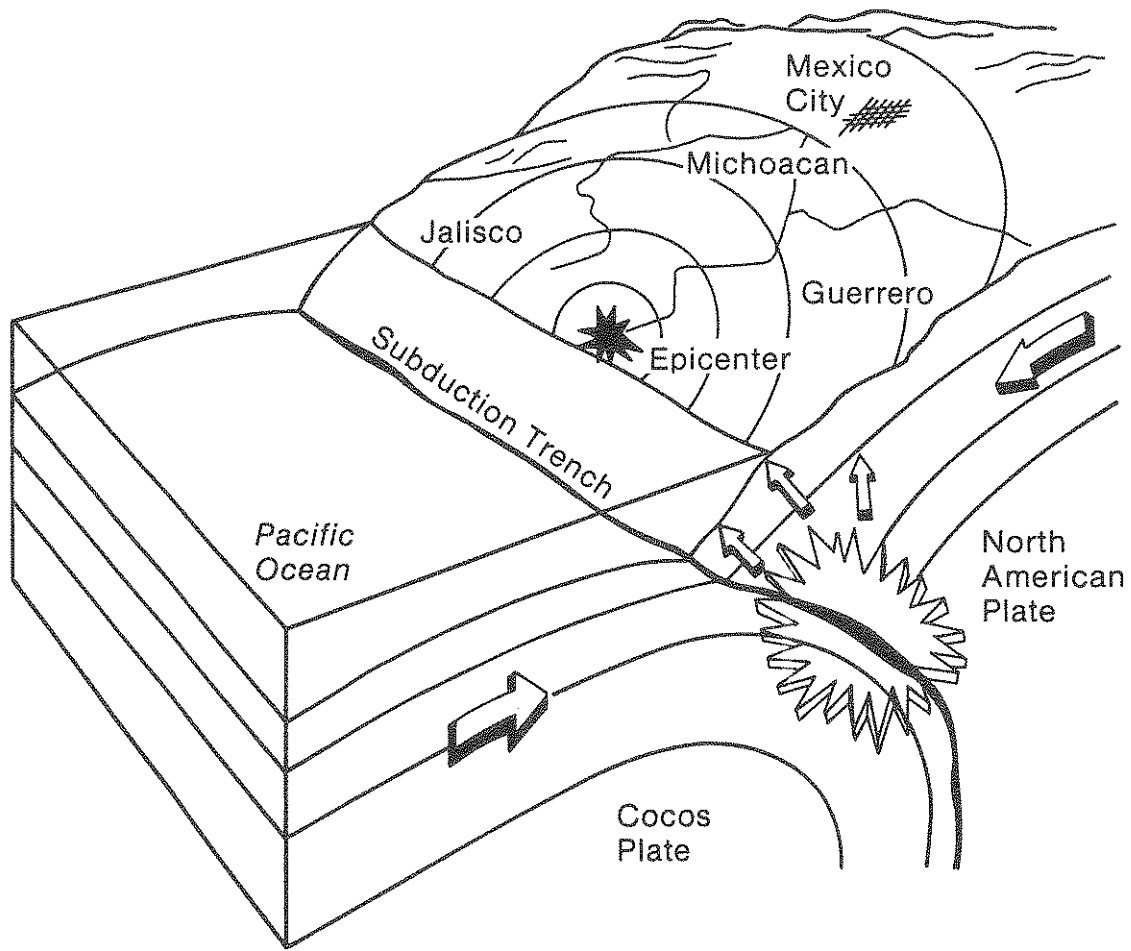

FIGURE 5-6 Movement Of Plates

Sosa ⊙
Texcoco

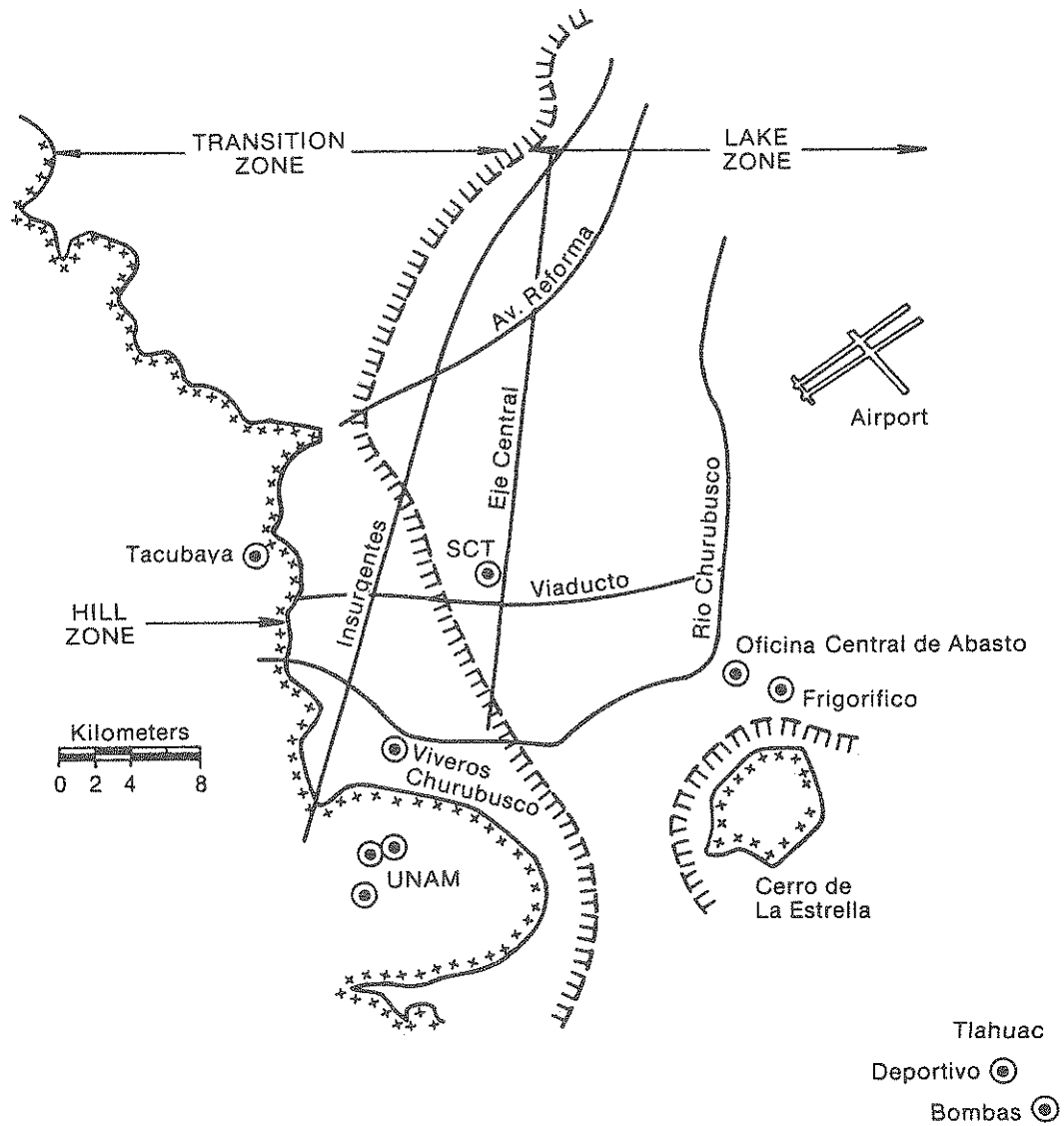

FIGURE 5-7 Location Of Strong Motion Instruments In The Valley Of Mexico

frequency content and large amplification in the Lake Zone. Figure 5-7 shows the location of the recording stations in the Valley of Mexico. Table 5-I presents the peak ground acceleration, velocity and displacement for both horizontal components at each of the Valley of Mexico stations. Table 5-II lists the average values for the peak horizontal ground parameter in the Hill, Transition and Lake Zones respectively. Note that the acceleration in the Lake Zone is roughly three times that for Hill Zone, while the Lake Zone velocities and displacements are roughly four times the Hill Zone values.

A rough measure of the predominate period of ground motion can be determined by assuming simple harmonic motion. Under this assumption, the predominant period becomes

$$T = 2\pi \frac{D_{\max}}{V_{\max}} \quad 5.1$$

where D_{\max} and V_{\max} are the peak ground displacement and velocity respectively. Using this measure, the predominate periods of ground motion ranged from about 2.5 to 5.5 seconds for the stations in Table 5.I. Note that these strong ground motion predominate periods are somewhat longer than those from microtremor measurement shown in figure 5.4.

TABLE 5-I Maximum Horizontal Acceleration, Velocities And Displacements Recorded In The Valley Of Mexico City - 1985 Michoacan Earthquake

Site	Orientation	Max Acceleration (gals)	Max Velocity (cm/sec)	Max Displacement (cm)	Soil zones
1 Central de Abastos - Frigorifico	NS	80.6	24.8	15.0	Lake zone
	EW	94.6	37.6	18.9	
2 Central de Abastos - Oficinas	NS	69.2	35.0	25.1	Lake zone
	EW	80.4	41.9	24.6	
3 Cd. Universitaria Laboratorios	NS	28.1	10.2	6.0	Hill zone
	EW	33.5	9.4	7.0	
4 Cd. Universitaria Patio	NS	31.7	10.3	6.2	Hill zone
	EW	34.7	9.4	8.0	
5 Cd. Universitaria Mesa. Vib.	NS	37.4	9.2	6.0	Hill zone
	EW	38.8	11.0	4.0	
6 Tacubaya	NS	34.4	14.3	12.0	Hill zone
	EW	33.2	9.8	8.6	
7 S.C.T.	NS	98.0	38.7	17.4	Lake zone
	EW	168.0	60.5	21.2	
8 Viveros	NS	44.1	11.5	9.1	Transition zone
	EW	42.4	12.2	7.5	
9 Tlahuac Bombas	NS	135.9	64.1	36.6	Lake zone
	EW	106.7	44.6	39.3	
10 Tlahuac Deportivo	NS	117.7	34.9	20.8	Lake zone
	EW	115.6	36.1	22.1	

TABLE 5-II Average Values Of Peak Ground Motion Parameters For The Valley Of Mexico By Zone (1985 Michoacan Earthquake)

Average Peak Value			
Zone	Acceleration (gals)	Velocity (cm/sec)	Displacement (cm)
Hill	35.4	11.45	8.25
Transition	44.1	12.2	9.1
Lake	119.3	48.0	25.3

SECTION 6
WATER SYSTEM DAMAGE IN METROPOLITAN MEXICO CITY; SEGMENTED PIPELINE

In this section information about damage to segmented pipelines in the water systems of Metropolitan Mexico City caused by the 1985 Michoacan earthquake is presented. Available damage statistics are organized and processed into a form suitable for engineering use.

There was no observed evidence of liquefaction in the metropolitan area. This is not unexpected since the subsurface consists primarily of volcanic rock or soft clay overlaying volcanic rock. In addition there were no landslides or faulting which effected the metropolitan water system. There were some earthquake induced ground settlement as evidenced by ground cracks. However the water system damage was not restricted to the ground settlement areas. Hence it appears that most of the water system damage was due to seismic wave propagation. This damage was mainly in the buried pipelines which comprise the transmission and distribution network. There was some isolated damage to well shafts but essentially no seismic damage to purification plants, pumping stations, reservoirs and other storage facilities.

6.1 Segmented Transmission System Damage

Buried aqueducts located in the southeast part of the city were severely damaged by the 1985 Michoacan earthquake. These large diameter prestressed concrete transmission pipelines had previously been damaged by the 1979 Guerrero earthquake, as previously noted in Section 2. However the breaks due to the 1985 event were more numerous than those due to the 1979 event.

The damaged aqueducts were located south of the Cerro de le Estrella (Hill of the Star) and the Cerro de Sta. Catarina (Hill of St. Catarina). Two aqueduct systems pass through this area. One aqueduct system is controlled by the Federal District (D.F.) while the other is controlled by the Comision de Aguas del Valle de Mexico (CAVM). Plan views showing the aqueduct routes and damage locations along the routes are shown in figures 6-1 and 6-2 for the DF aqueduct and the CAVM aqueduct respectively. In figure 6-1, the cross-hatched aqueduct indicates the general area where leaks occurred in the D.F. aqueduct, while the specific locations of damage for the CAVM aqueduct

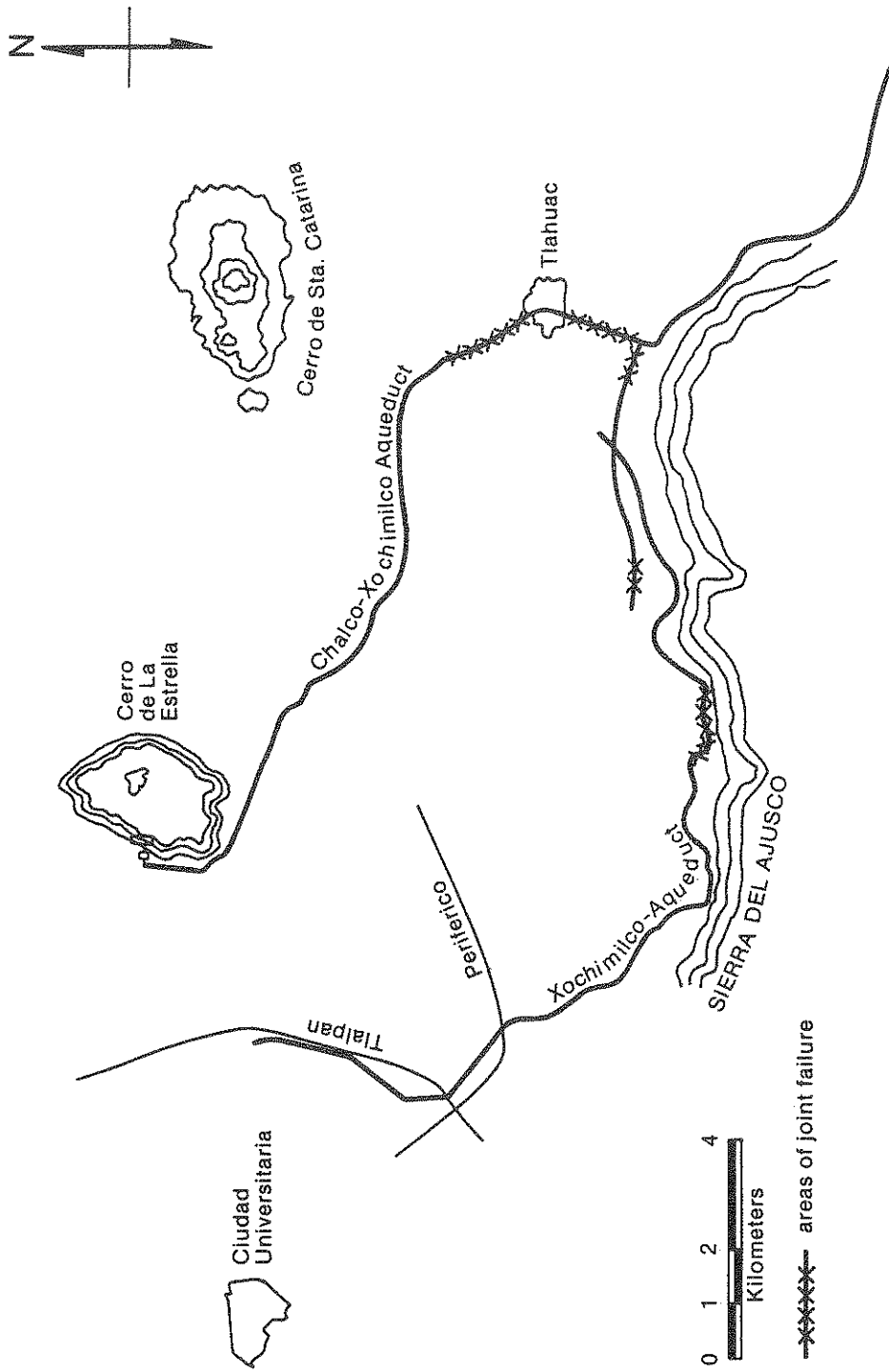

FIGURE 6-1 Aqueducts In Southeastern Mexico City Controlled By The Federal District

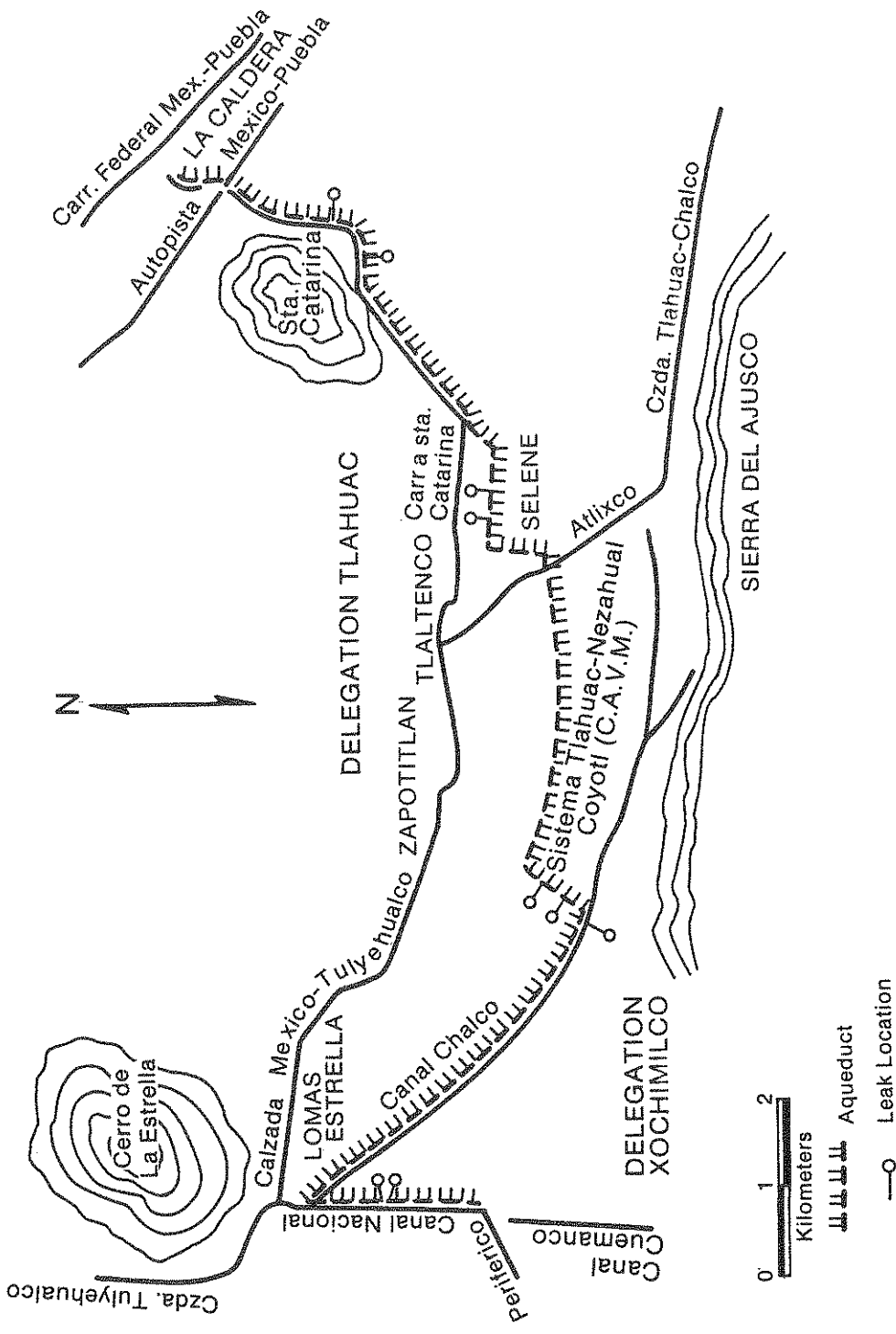

FIGURE 6-2 Aqueducts In Southeastern Mexico City Controlled By C.A.V.M.

are shown in Figure 6-2. For almost the total length, both aqueduct systems are buried in extremely soft alluvial deposits. The 1985 Michoacan earthquake occurred at the end of the rainy season and the water table was within the 1.5 m (4.5 ft.) of the ground surface at that time.

6.1.1 Federal District Aqueduct

There were 60 pipeline breaks (or leaks requiring repair) along the D.F. aqueduct. This yields a damage ratio of 1.7 breaks/km in the affected zone in the southeast part of Mexico City. The distribution of the damage was as follows.

- a. 40 breaks occurred at joints where adjacent segments crushed or separated due to insufficient joint flexibility. All of these breaks were in 36" or 72" diameter "lock joint" prestressed concrete pipe. Typical damage is shown in figure 6-3 and 6-4.
- b. 11 joint failures occurred at a "T" junction in a 72" diameter lock joint line. These failures occurred in the line which formed the "stem" of the "T" (ie, the line deadended by the trust block.) Again these failures were due to crushing and/or separation of the joints. Figure 6-5 shows the damage.
- c. Three 30"φ pipes separated at their joints at a siphon location in the aqueduct. The separation was caused by the rupture of the steel belts that held the sections together.
- d. In the neighborhood of San Isidro, 6 separate failures occurred over a distance of about 500 m. The breaks were caused by severe ground cracking as shown in figure 6-6. The ground cracks were caused by the earthquake in combination with long term regional subsidence.

In addition to the pipeline joint damage described above, the earthquake caused "punching shear" cracking of valve box walls as shown in figure 6-7. It is worth noting that much of the above mentioned damage occurred at joints close to junctions such as "T"s or elbows.

6.1.2 Comision de Aguas del Valle de Mexico Aqueduct

In the CAVM aqueduct, there were 8 breaks in a 48"φ "lock joint" pipe and one

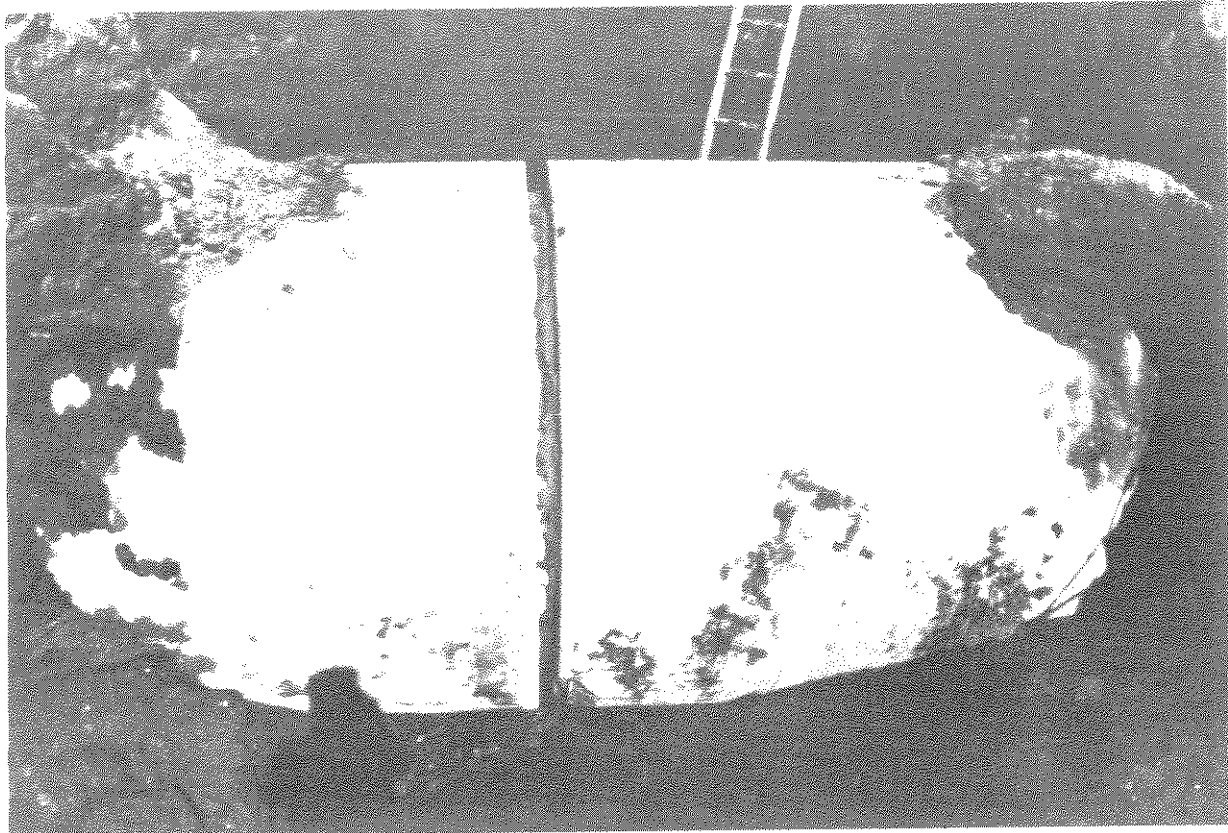

FIGURE 6-3 Joint Separation In A 72"φ 'Lock Joint' Pipe,
1985 Michoacan Earthquake

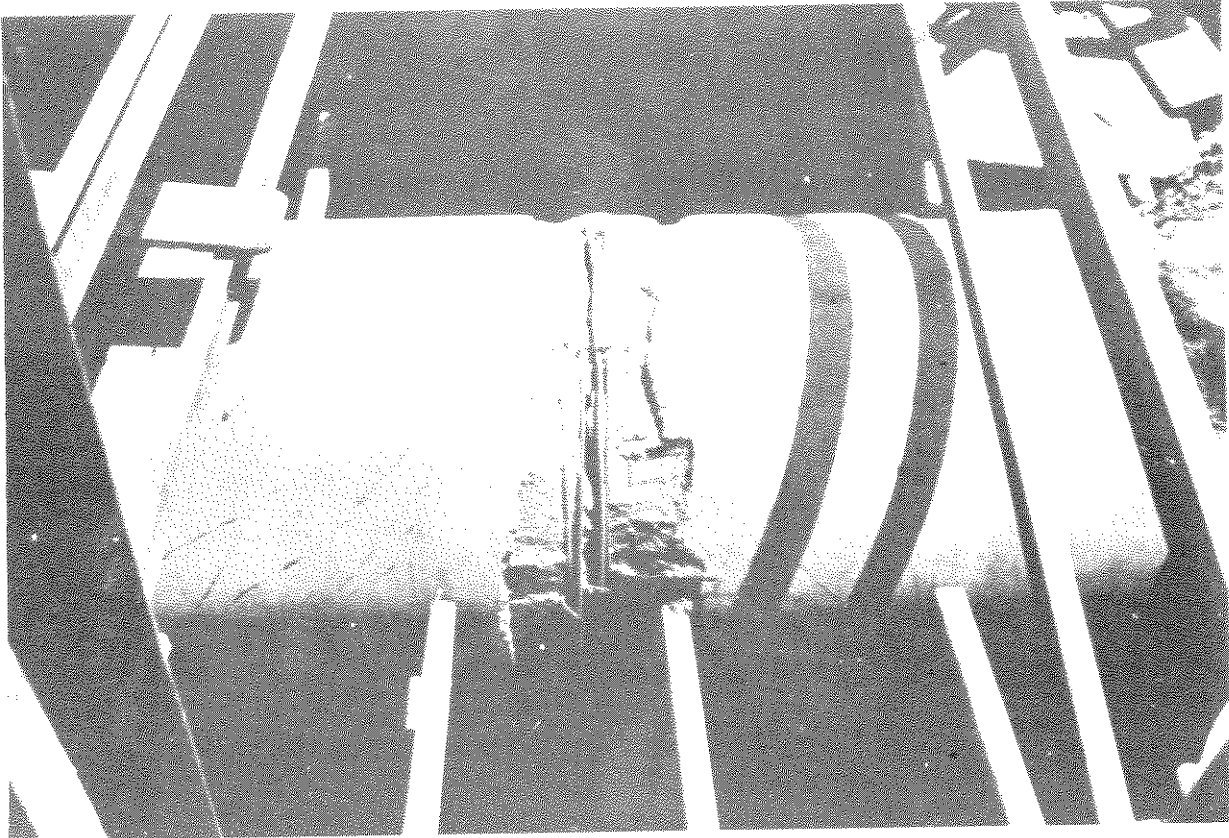

FIGURE 6-4 Crushing Failure In A 72"φ 'Lock Joint' Pipe,
1985 Michoacan Earthquake



FIGURE 6-5 Joint Separation At 11 Points Close To A "T" Junction, 1985 Michoacan Earthquake

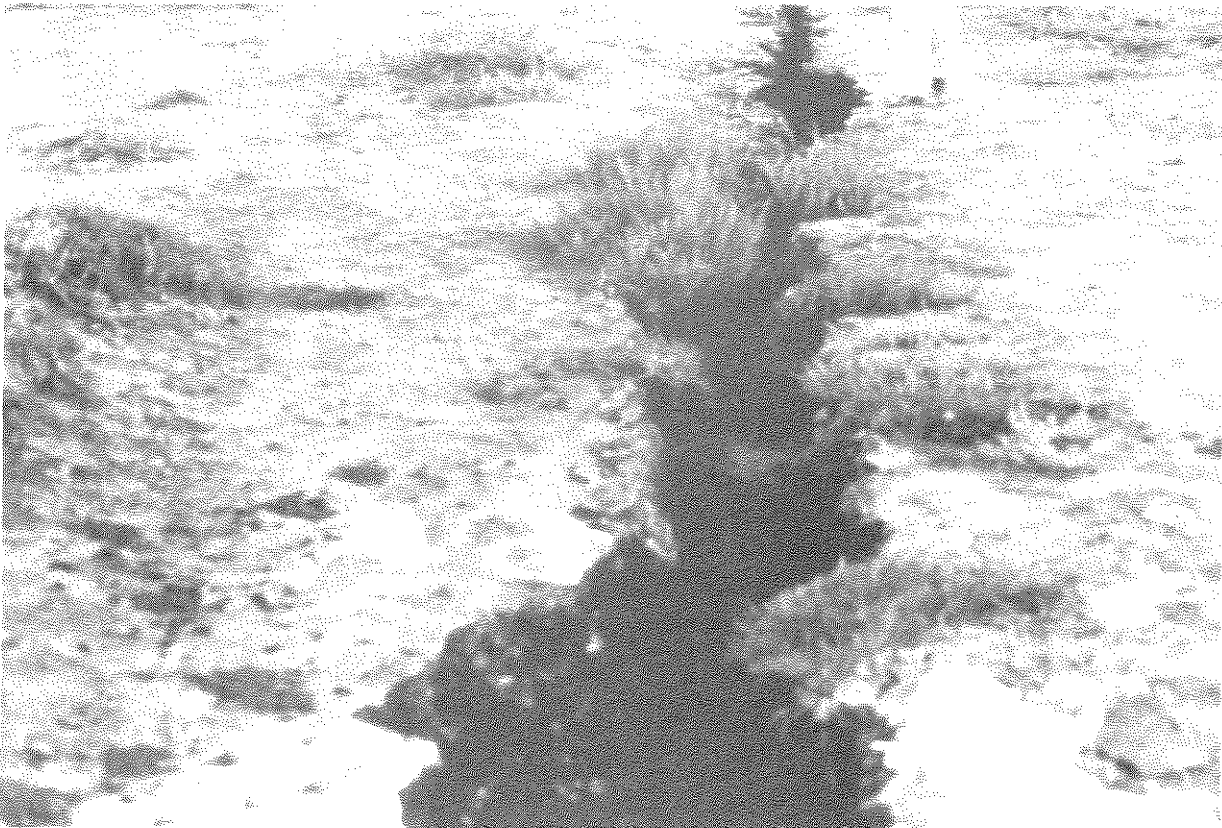

FIGURE 6-6 Severe Ground Cracking In The Vicinity Of The Aqueducts,
1985 Michoacan Earthquake



FIGURE 6-7 Cracking At A Valve Box Wall

break in a 42"φ pipe. Although the CAVM aqueduct damage was similar in many respects to that which occurred in the D.F. aqueduct, the number of leaks were significantly lower. The damage was due to seismic wave propagation in soft ground conditions. The leaks or breaks typically occurred at joints in the large diameter prestressed concrete pipe. In addition, joints near T or elbows junctions appeared to have a somewhat higher probability of damage compared to joints in long straight runs of segmented pipe.

The difference in the number of breaks between the CAVM aqueduct and the D.F. aqueduct is primarily due to location and orientation. Although both aqueducts are located in the southeastern region of the metropolitan area the CAVM aqueduct generally runs East-West and skirts the south side of the Cerro de St. Catarina, while the most heavily damaged portion of the D.F. aqueduct runs thru the town of Tlahuac.

6.1.3. Analysis of Transmission Systems Damage

As mentioned above, the 1985 Michoacan Earthquake damaged aqueducts in the southeastern region of Mexico City but did not significantly damage aqueducts in other parts of the metropolitan area. Ground motions recorded in the valley south of the Cerro de La Estrella indicate large ground displacement amplitudes as well as significant local variation in displacement amplitudes. This is most probably the reason why transmission system damage was concentrated in the southeast part of the metropolitan area. Other contributing factors are ground subsidence and prior repairs. These contributing factors, however, are applicable for all the aqueducts in Mexico City and hence do not by themselves explain the concentration of damage in the southeast.

Figure 6-8 shows the two damaged aqueducts located between the Cerro de la Estrella and the Cerro de Santa Caterina to the north and the Sierra del Ajusco to the south. An approximate elevation view is shown in figure 6-9. Tlahuac, which is considered to be in the Lake Zone, is located in the valley between these two groups of mountains. There were two seismographs located in Tlahuac; one at a pump station (Tlahuac Bombas, TLHB) and another at a sports club (Tlahuac Deportivo, TLHD). Two other Lake Zone seismographs were recorded north of the Cerro de la Estrella and the Cerro de Santa Catarina, at

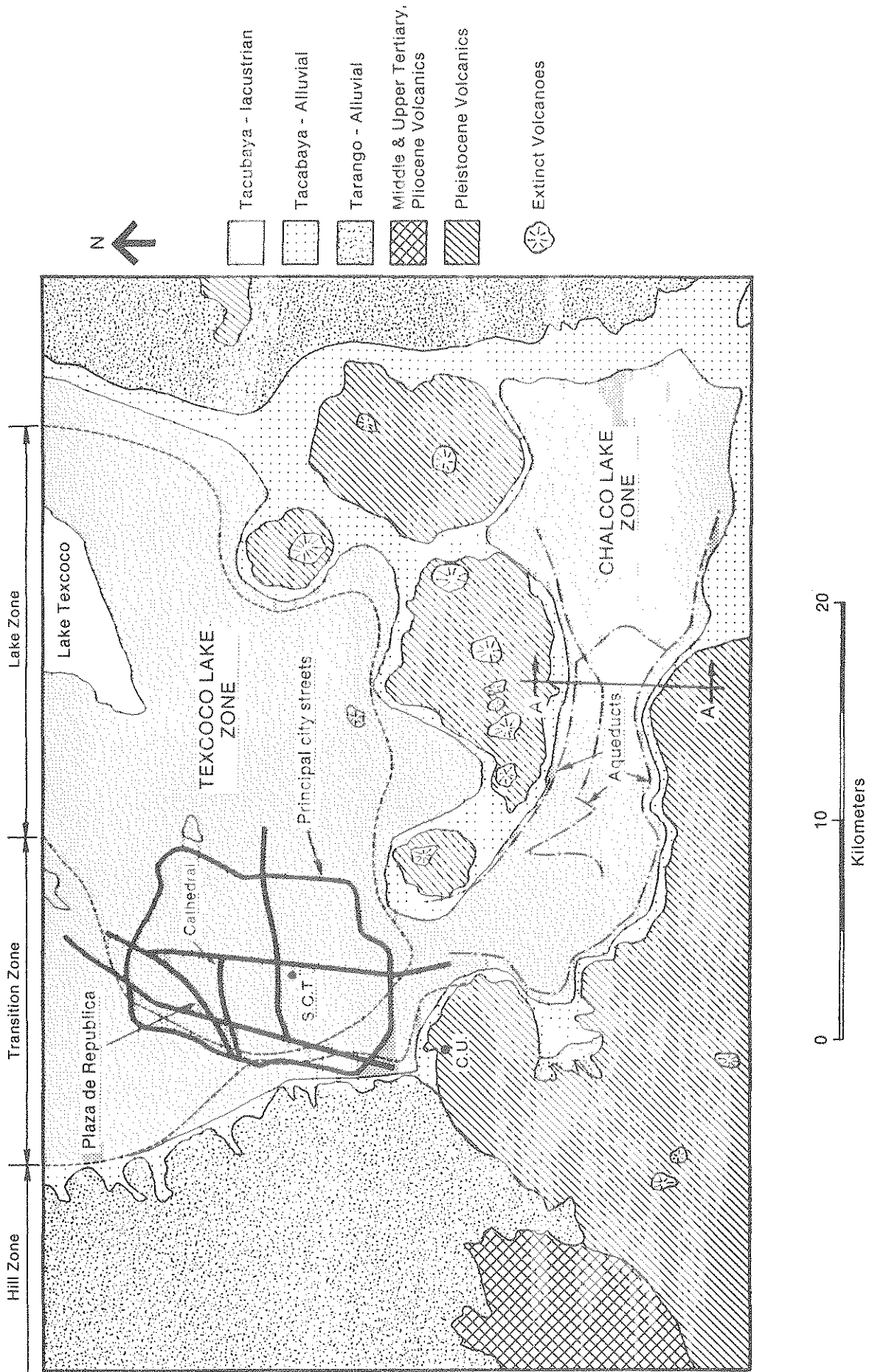

FIGURE 6--8 Location Of Damaged Aqueducts With Respect To Surrounding Mountains

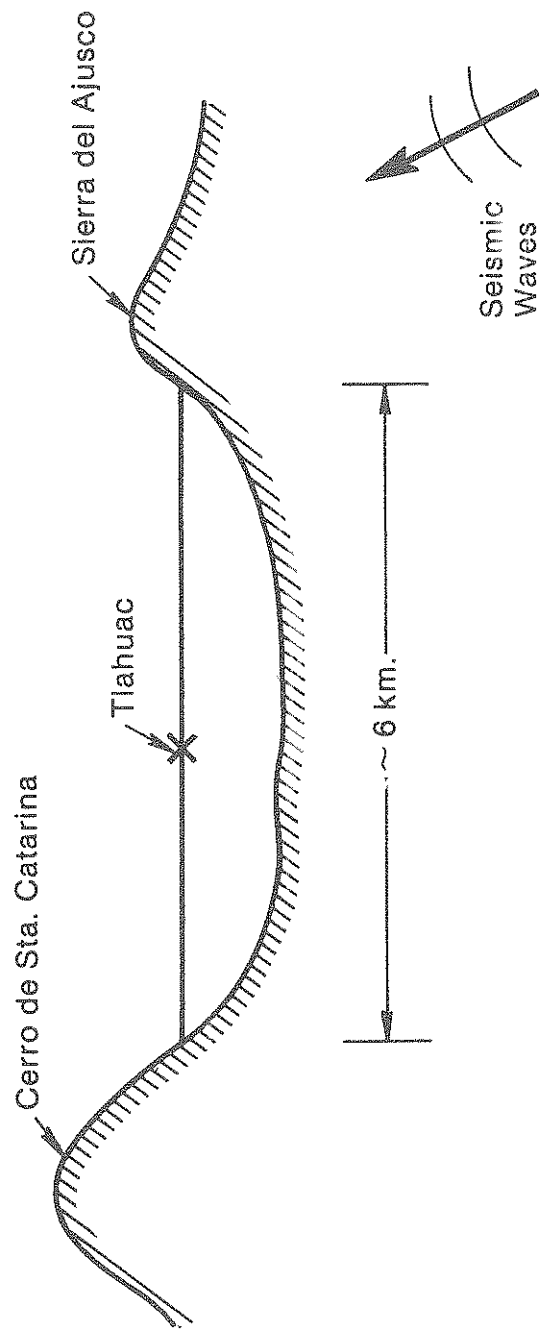

FIGURE 6-9 Idealized Elevation View Showing Tlahuac

Central de Abastos. As shown in table 5-I, the peak horizontal ground displacement at TLHB were the largest recorded in the Valley of Mexico.

The TLHB peak ground displacements were roughly 1.5 times larger than the next largest which were recorded at Central de Abastos. That is, during the 1985 event, the area of aqueduct damage experienced the largest recorded ground displacements.

Another important factor is the large local variation in ground displacement near Tlahuac. Tlahuac Bombas and Tlahuac Deportivo are separated by about 3 km. Yet the horizontal ground displacements at THLB were roughly double those of THLD. This difference is shown graphically in figures 6-10 and 6-11. The North-South ground displacement time histories at THLB and THLD are shown in figure 6-10 while the East-West components at the two stations is shown in Figure 6-11.

It is the authors belief that the local topology of this valley containing Tlahuac resulted in large ground displacement amplitudes as well as fairly severe local variations in ground displacement amplitudes. These factors in turn lead to the transmission system damage.

There were, however, other factors which may have contributed to the aqueduct damage. These are:

- a. The zone where the aqueducts are located is rapidly subsiding due to abatement of the water table. It is common to find ground cracks due to land subsidence in this area. As a result, buried pipeline in this region are subject, over time, to nonearthquake induced deformation. Hence the ability of the joints to accommodate earthquake induced deformation is reduced somewhat. Subsidence is discussed in somewhat more detail in Section 6-4.
- b. Leaks frequently occur at joints due to the subsidence induced deformation of the soil around the aqueducts. In most instances repairs are made using steel saddles, as shown in figure 6-12. Such repairs drastically reduce the flexibility of the repaired joint. As a result the adjacent unrepaired joints would be subject to somewhat higher seismically induced joint deformation because

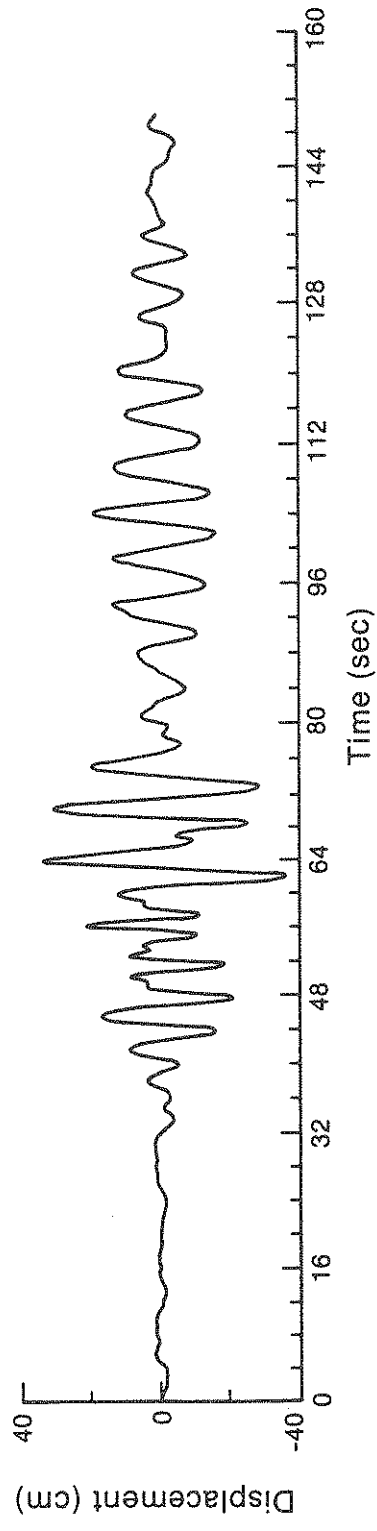

a) Tlahuac Bombas (TLHB)

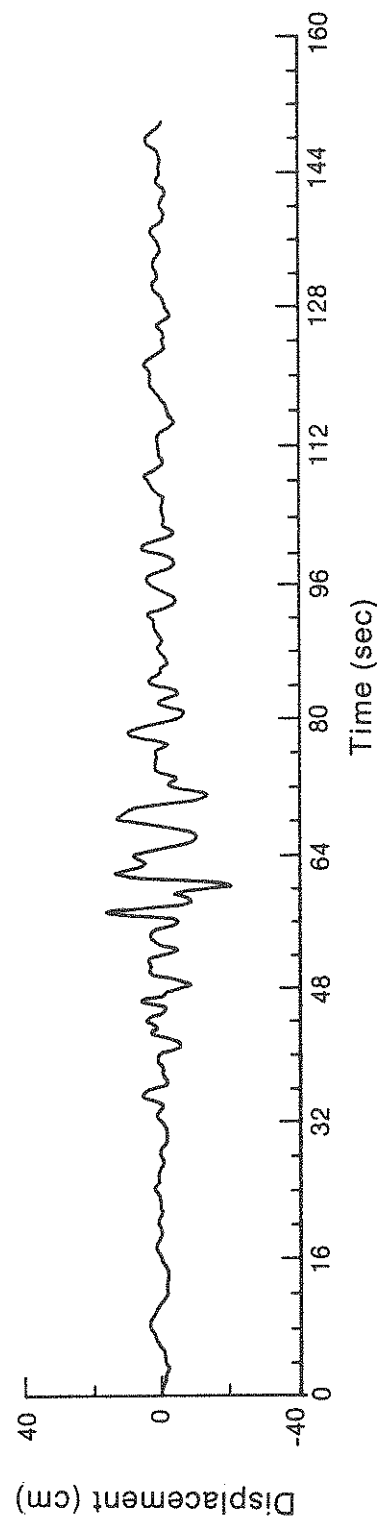

b) Tlahuac Deportivo (TLHD)

FIGURE 6-10 North-South Ground Displacement Time Histories At Tlahuac - 1985 Michoacan Earthquake

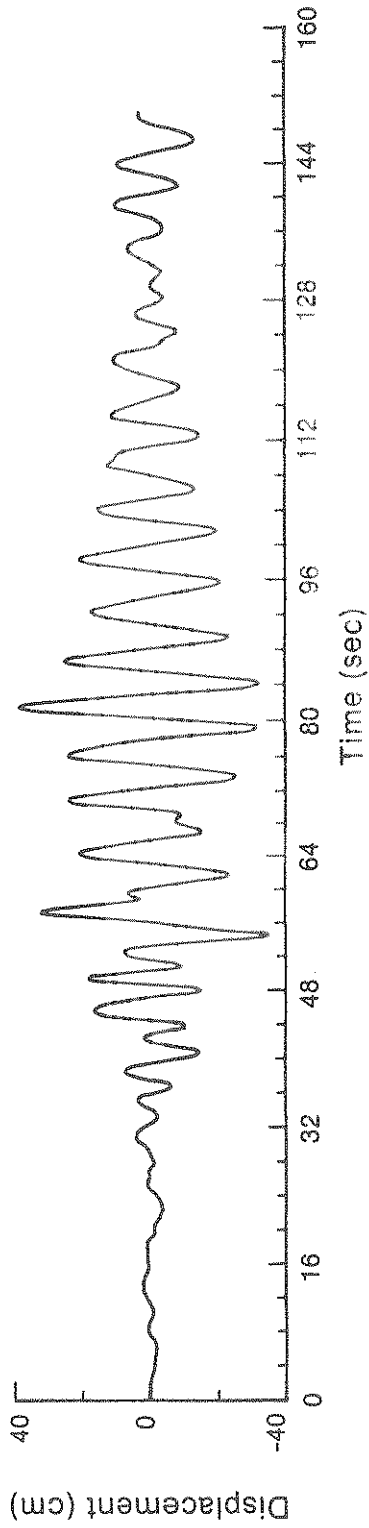

a) Tlahuac Bombas (TLHB)

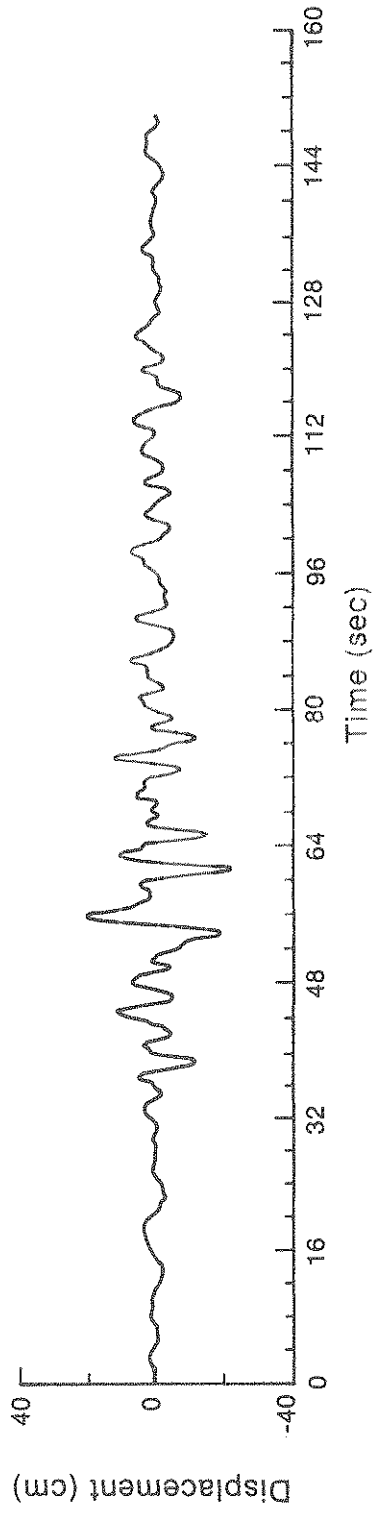

b) Tlahuac Deportivo (TLHD)

FIGURE 6-11 East-West Ground Displacement Time History At Tlahuac - 1985 Michoacan Earthquake

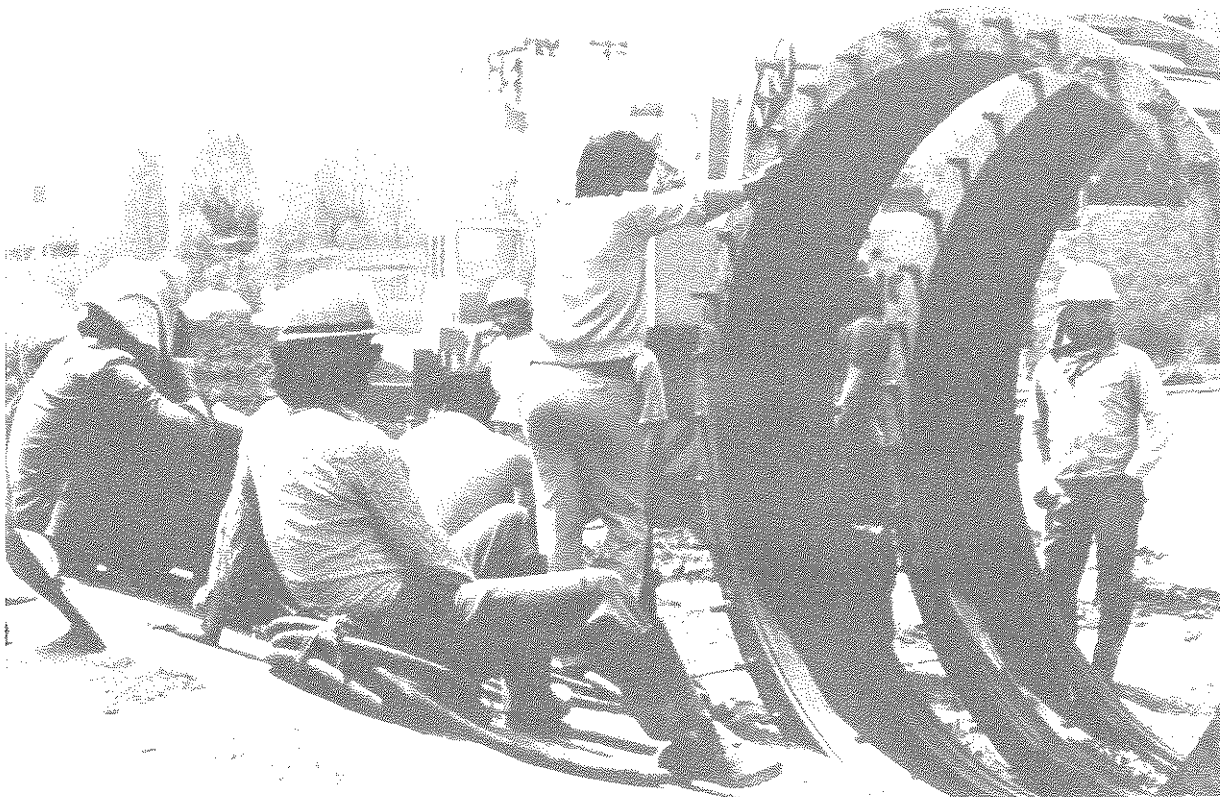

FIGURE 6-12 View Of A Steel Repair Saddle

of the presence of the relatively inflexible repaired joints.

- c. During the inspection of the different aqueducts it was found that degradation of the different components had taken place due to natural aging, root damage and erosion due to leaks.

Note, however, that these factors (subsidence, repairs and degradation) are common to all aqueducts in the city. Hence these factors by themselves do not explain why only aqueducts in the southeastern part of the metropolitan area were heavily damaged while aqueducts in other areas were not.

6.2 Distribution Systems Damage

The Michoacan earthquake caused considerable damage to both primary and secondary lines in the Federal District and the State of Mexico water distribution systems serving the metropolitan area.

6.2.1 Primary Distribution Pipelines in D.F.

Within the Federal District, most of the damage to primary distribution lines (20" diameters and larger) were in asbestos cement and concrete pipes. The breaks were reported as transverse cracks in pipes, crushing or pull-out at joints, and fracture of special pieces at valve boxes. Failures also occurred in cast iron pipelines. Some of these cast iron failures were in heavily corroded pipes in the older parts of the city. An example is a fracture of a "T" joint in a 36 in diameter pipeline shown in figure 6-13. This line was constructed at the beginning of the century and is located in a open gallery in the older part of the city. The line had survived previous strong earthquakes without damage and had experienced no significant corrosion or cracking prior to the September 1985 event.

Table 6-I presents the length, per "Delegacion", of various diameters of primary distribution lines within the Federal District. Table 6-II lists the number of breaks, per Delegacion, for various pipe diameters as well as the corresponding damage ratios.

A summary of damage information for the primary distribution system in the Federal District is presented in table 6-III. The length per diameter,



FIGURE 6-13 Fractured Cast Iron "T", 1985 Michoacan Earthquake

TABLE 6-I Pipeline Lengths For The Primary Distribution System In The Federal District (D.F.)

DELEGACION	(Pipeline Lengths (in km) for various Diameters (in inches))										TOTAL
	20"	24"	30"	32"	36"	42"	48"	72"			
Benito Juarez	9.3	-	-	-	8.4	-	22.4	-	-	40.1	
Coyoacan	14.8	-	-	-	3.3	-	20.9	-	-	39.0	
Tlalpan	1.0	0.7	-	-	-	-	0.6	-	-	2.3	
Iztacalco	5.7	-	3.4	-	5.0	2.4	17.4	-	-	33.9	
Azcapotzalco	8.5	-	-	-	7.5	-	29.1	-	-	45.1	
Venustiano Carranza	12.7	-	-	4.0	11.1	7.8	12.9	-	-	48.5	
Cuauhtemoc	2.9	-	-	6.1	14.1	-	28.5	-	-	51.6	
Gustavo A. Madero	44.0	-	-	-	16.9	-	40.8	12.4	-	114.1	
Cuajimalpa	2.8	-	-	-	-	-	-	-	-	2.8	
Magdalena Contreras	1.7	-	-	-	1.4	-	4.2	-	-	7.3	
Miguel Hidalgo	18.4	-	-	-	7.2	3.5	13.4	-	-	42.5	
Alvaro Obregon	2.6	-	-	-	*	-	31.9	-	-	34.54	
Iztapalapa	28.1	-	2.9	-	8.2	*	53.1	-	-	92.4	
Xochimilco	1.5	-	-	-	9.0**	-	-	-	-	10.5	
Milpa Alta	0.9	-	-	-	-	-	-	-	-	0.9	
Tlahuac	3.2	-	-	-	-	-	-	-	-	3.2	
TOTALS	158.0	0.7	6.3	10.1	92.1**	13.7**	275.3	12.4	-	568.6	

* Not Available

** Estimated

TABLE 6-II Leak Rate And Number Of Leaks For Primary Distribution System Lines In The Federal District

DELAGACION	20"	24"	30"	32"	36"	42"	48"	72"	TOTALS OF BREAKS
	(Leak Rate (in Repairs/km.) for Various Diameters)								
Benito Juarez	0.0(0)	-	-	-	0.96(8)	-	0.09(2)	-	10
Coyoacan	0.0(0)	-	-	-	0.0(0)	-	0.0(0)	-	0
Tlalpan	0.0(0)	0.0(0)	-	-	-	-	0.0(0)	-	0
Iztacalco	0.88(5)	-	0.59(2)	-	0.20(1)	0.0(0)	0.63(11)	-	19
Azcapotzalco	0.0(0)	-	-	-	0.13(1)	-	0.03(1)	-	2
Venustiano Carranza	0.79(10)	-	-	1.74(7)	1.44(16)	0.0(0)	0.31(4)	-	37
Cuauhtemoc	1.38(4)	-	-	1.31(8)	0.78(11)	-	0.32(9)	-	32
Gustavo A. Madero	0.30(13)	-	-	-	0.36(6)	-	0.32(13)	0.0(0)	32
Cuajimalpa	0.0(0)	-	-	-	-	-	-	-	0
Magdalena Contreras	*	-	-	-	*	-	*	-	*
Miguel Hidalgo	0.05(1)	-	-	-	0.0(0)	0.0(0)	0.0(0)	-	1
Alvaro Obregon	0.0(0)	-	-	-	?(6)	0.0(0)	0.06(2)	-	8
Iztapalapa	0.07(2)	-	0.34(1)	-	0.12(1)	?(3)	0.41(22)	-	29
Xochimilco	0.0(0)	-	-	-	0.56(5)	-	-	-	5
Milpa Alta	0.0(0)	-	-	-	-	-	-	-	0
Tlahuac	0.0(0)	-	-	-	-	-	-	-	0

Federal District Average = 31

* unconfirmed information
number of breaks in ()

TABLE 6-III Summary Of Damage Statistics For The Primary Distribution Network
In The Federal District

Diameter (in)	Length (km)	Repairs	Rate (Repairs/km)	% Repair	% Length
20"	118.0	35	.2215	.120	28.40
30"	6.3	3	.4748	.72	1.13
32"	10.1	15	1.4822	8.57	1.81
36"	92.1	55	.597	31.43	16.58
42"	13.7	3	.2187	1.72	2.45
48"	275.4	64	.232	36.66	49.55

percentage of total system length, number of breaks per diameter, percentage of total breaks, and failure rate per diameter are shown in this summary table. Notice that the average rate, that is the number of repaired leaks or breaks, in the primary distribution system in the Federal District was 0.31 repairs per km. It should be mentioned that a leak or break did not necessarily result in a total inability to transmit water through the damaged segment. Some leaks were temporarily left unrepaired in order to provide reduced service to downstream users.

The geographical location of most of the D.F. primary distribution piping breaks were in the lacustrine soil region of the Texcoco and Chalco lakes (Lake Zone). These are shown in figure 6-14. On a smaller geographical scale, a substantial number of leaks/breaks occurred at joints located close to bends, T's, elbows and other hard spots such as junction boxes.

It appears that approximately two thirds (66%) of the leaks/breaks occurred near such junctions while about one quarter (25%) occurred along nominally straight runs of pipe. The precise location of about one tenth (10%) of the leaks/breaks could not be determined.

6.2.2 Secondary Distribution Pipelines in the D.F.

The secondary distribution system controlled by the Federal District was also heavily damaged. As with the primary distribution system, secondary distribution pipelines in the Lake Zone were the most affected as shown in figure 6-15. In addition to the damage characteristics discussed above, a large number of old pipes made of clay and cast iron also broke. It appears that the older components were too rigid or too deteriorated to sustain any substantial earthquake induced deformation. Many special pieces, such as valves, connections, etc in the 2" to 18" diameter range failed. Table 6-IV present statistics of the reported damage while figures 6-16 and 6-17 show typical damage.

6.2.3 Distribution Pipelines in the State of Mexico

The distribution network in 'Ciudad Nezahualcoyotl, located in the State of Mexico, suffered about 750 leaks. Most of these occurred at joints close to



FIGURE 6-14 Well Documented Pipeline Damage In Primary Distribution System Of Federal District - 1985 Michoacan Earthquake

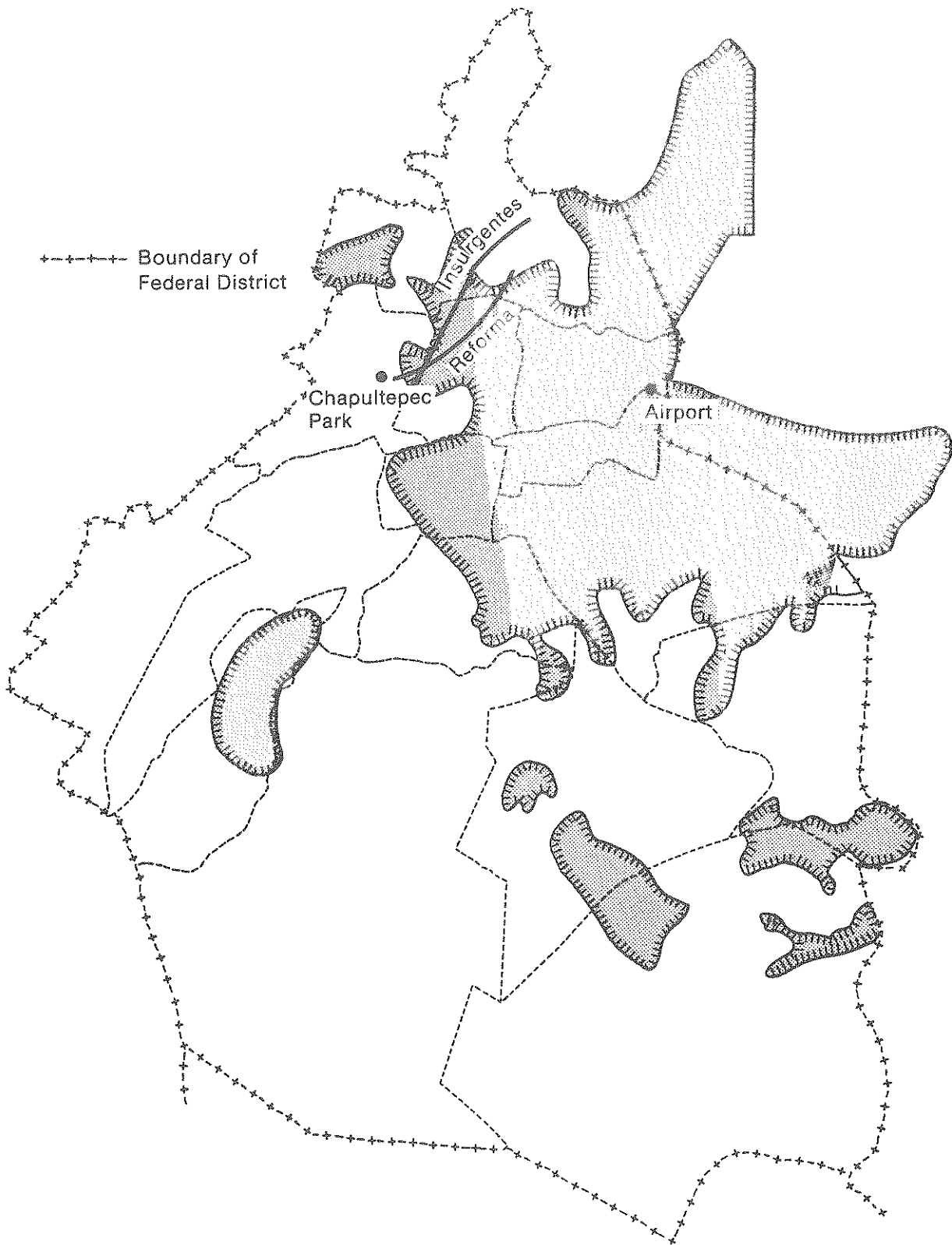

FIGURE 6-15 Areas Of Secondary Distribution System Damage - 1985 Michoacan Earthquake

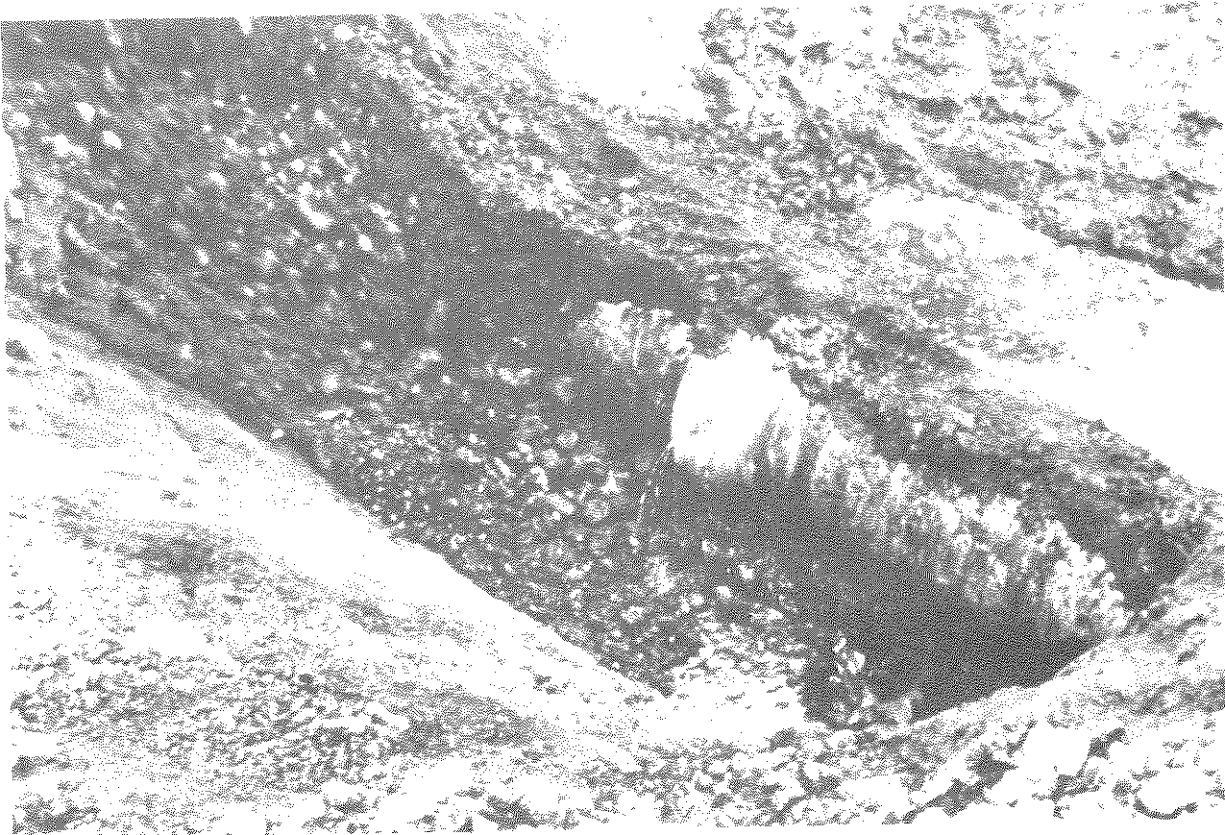

FIGURE 6-16 Leak At The Bell Of An Asbestos Cement Pipe, 1985 Michoacan Earthquake



FIGURE 6-17 Break Near Joint Of An Asbestos Cement Pipe, 1985 Michoacan Earthquake

TABLE 6-IV Number Of Leaks/Breaks Per 'Delegacion' In The Secondary Distribution System In The Federal District

Delegacion	Diameter Of Pipeline, (In)												Total
	2	2 1/2	3	4	6	8	10	12	14	16	18	Other	
Azcapolzalco	8	0	0	53	15	1	0	11	0	0	1	236	325
Cuajimalpa	0	0	0	1	0	0	0	0	0	0	0	2	3
Tlalpan	0	0	0	56	6	1	0	4	0	0	0	6	73
Tlahuac	14	0	0	587	79	3	0	15	0	0	0	75	773
Coyoacan	0	0	1	27	11	0	0	8	0	0	0	34	81
Miguel Hidalgo	3	0	0	44	8	0	0	5	0	0	0	103	163
Magdalena Contreras	5	0	0	28	7	0	1	1	0	0	0	227	269
Alvaro Obregon	0	0	0	65	9	0	0	4	0	0	0	26	104
Benito Juarez	5	0	2	110	31	2	0	13	0	0	0	95	258
Xochimilco	1	0	0	414	16	0	0	3	0	0	0	29	463
Cuauhtemoc	24	0	0	74	117	1	1	26	0	0	0	119	362
Iztacalco	6	0	1	136	95	0	1	34	0	1	0	103	377
Venustiano Carranza	8	2	1	177	84	2	0	18	0	2	0	23	317
Iztapalapa	5	0	7	241	94	1	0	40	0	1	0	374	763
Gustavo A. Madero	16	0	1	341	64	3	5	51	0	0	0	303	784
Totals	95	2	13	2354	636	14	8	233	0	4	1	1755	5115

fixed points such as crossings, bends, 'T's', valve boxes etc., as shown in figure 6-18. Failures in the body of the pipes were less frequent and from discussion with engineers in charge of the repairs, these occurred along pipes already weakened by relative settlements which is common in all the urbanized areas of the Lake Zone. As may have occurred in the D.F, some of the failures may have occurred at the joints weakened by differential settlements. The failure rate for Ciudad Nezahualcoyotl was .831 breaks per km.

Damage to the water distribution system of the 'Municipio de Ecatepec' located in the State of Mexico, consisted of about 760 leaks. Unfortunately only 334 of these leaks are well documented. Table 6-V shows the number of documented failures for each diameter. Failures typically occurred at joints with characteristics similar to those in other damaged areas. For the documented leaks, the corresponding failure rate was 1.11 breaks per km.

Of interest is the damage to the well shaft supplying water to the 'Caldera' tank, as shown in figure 6-19. In addition the shafts of six wells located on the lake 'Nabor Carrillo' where damaged. The machinery of these wells was located 7m above the water surface. Hence the well shaft damage at Nabor Carrillo could have been due to inertia forces.

6.3 Service Connection

Street mains in Mexico City are generally buried at a depth of approximately 60 cm below the street surface. The small pipes which provide water to individual users from the street mains are called service connections. The service connections are attached perpendicular to the street main.

Damage statistics available to the authors indicate that most of the damage to the service connection occurred at its attachment point to the main. Seismic damage to service connections in the Federal District was fairly heavy while no service connection damage was reported in the State of Mexico.

An investigation of the different types of service connections used in the metropolitan area showed that in the affected area controlled by the Federal District, service connections were made of galvanized iron. These galvanized iron service connections shows some signs of deterioration due to corrosion

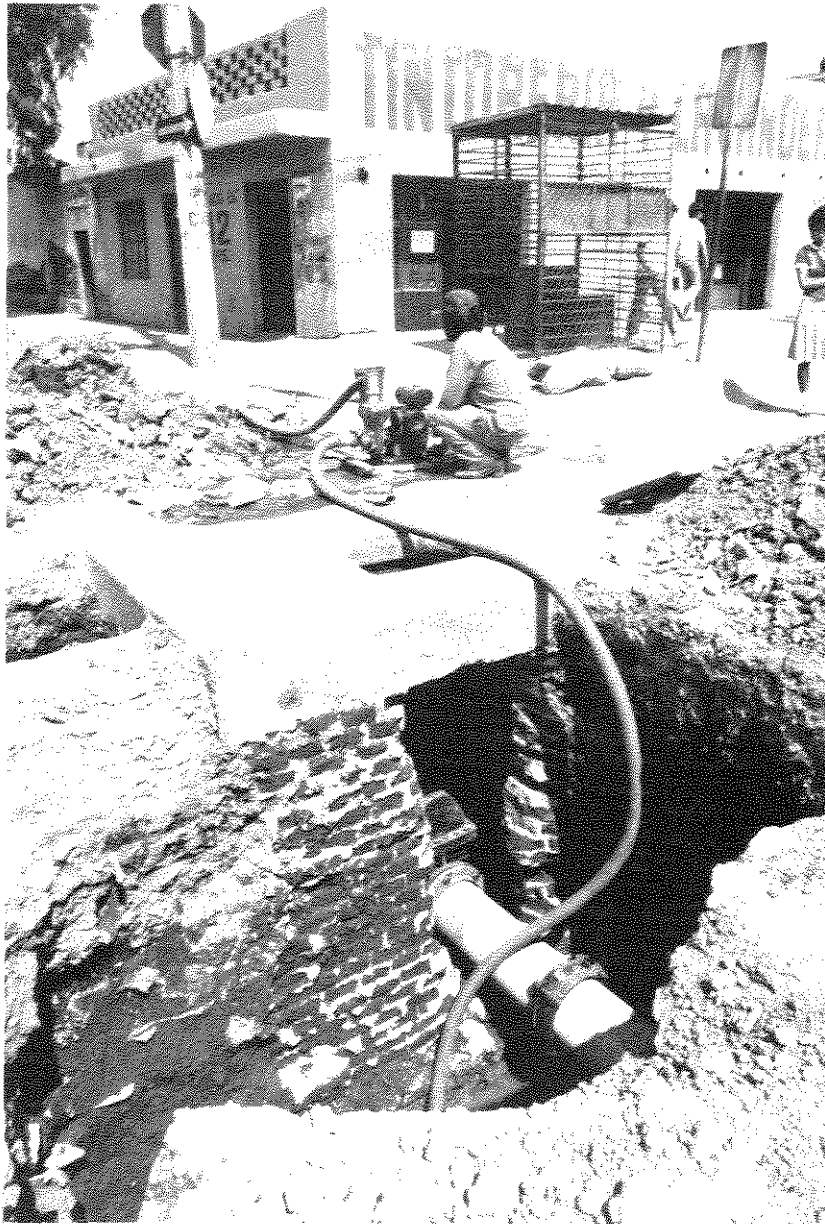

FIGURE 6-18 Repaired Leak At A Valve Box

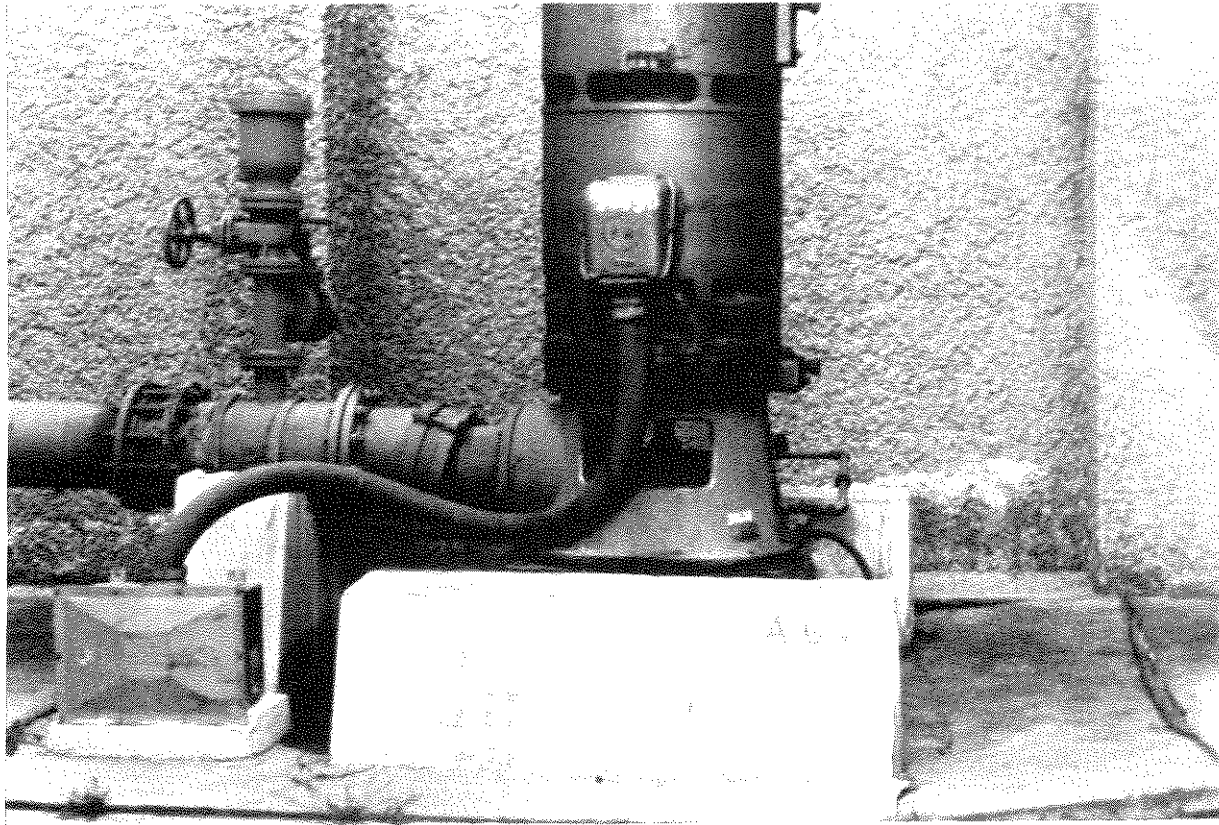

FIGURE 6-19 Well Damage At 'La Caldera' Tank, 1985 Michoacan Earthquake

TABLE 6-V Available Damage Statistics For The Municipio De Ecatepec

Diameter(in)	1/2	2 1/2	3	4	6	8	12	24	30	36	48
# of leaks.	185	15	68	26	14	9	7	1	2	1	1

and also produced a relatively rigid connection at the street main service connection interface. On the other hand, service connections in the State of Mexico were made of plastic materials such as PVC. A typical flexible service connection that behaved successfully during the Michoacan earthquake is shown in figure 6-20.

Apparently the flexible service connections used in the State of Mexico were able to accommodate, without failure, the seismically induced ground deformation. Many of the more rigid service connections used in the Federal District typically broke at the service connection street main interconnection point when subject to similar intensities of ground deformation.

6.4 Subsidence

As mentioned in section 6.1.3, long term subsidence is a possible contributing factor to seismic damage experienced by the Mexico City water systems. This subsidence is due to the removal by pumping of subsurface water and is most pronounced in the older parts of the city. Ground settlement versus time for two sites in the older part of the city is shown in figure 6.21. Note that during the thirty year period from 1940 to 1970, the ground settled about 5 meters at these two sites.

The settlement however was not uniform as shown by the equal subsidence contours in figure 6-22. In 1970 the settlement along Melchor Ocampo was between 3.0 and 3.5m. while the settlement along one section of Avenue Juarez was 8.5m. These two locations are separated by about 2000m. Assuming the 2 km separation distance between the Melchor Ocampo and the Ave. Juarez sites remained constant since the turn of the century, (ie since substantial subsidence began) the subsidence induced ground strain between the two sites would have been about 3.1×10^{-6} in 1970. This subsidence induced ground strain is illustrated in figure 6-23.

As will be shown in Section 7, the earthquake induced ground strain in the Lake Zone soils are estimated to be at least two orders of magnitude larger than the subsidence induced ground strain calculated above. Hence although subsidence surely caused deformation at the joints of the segmented water

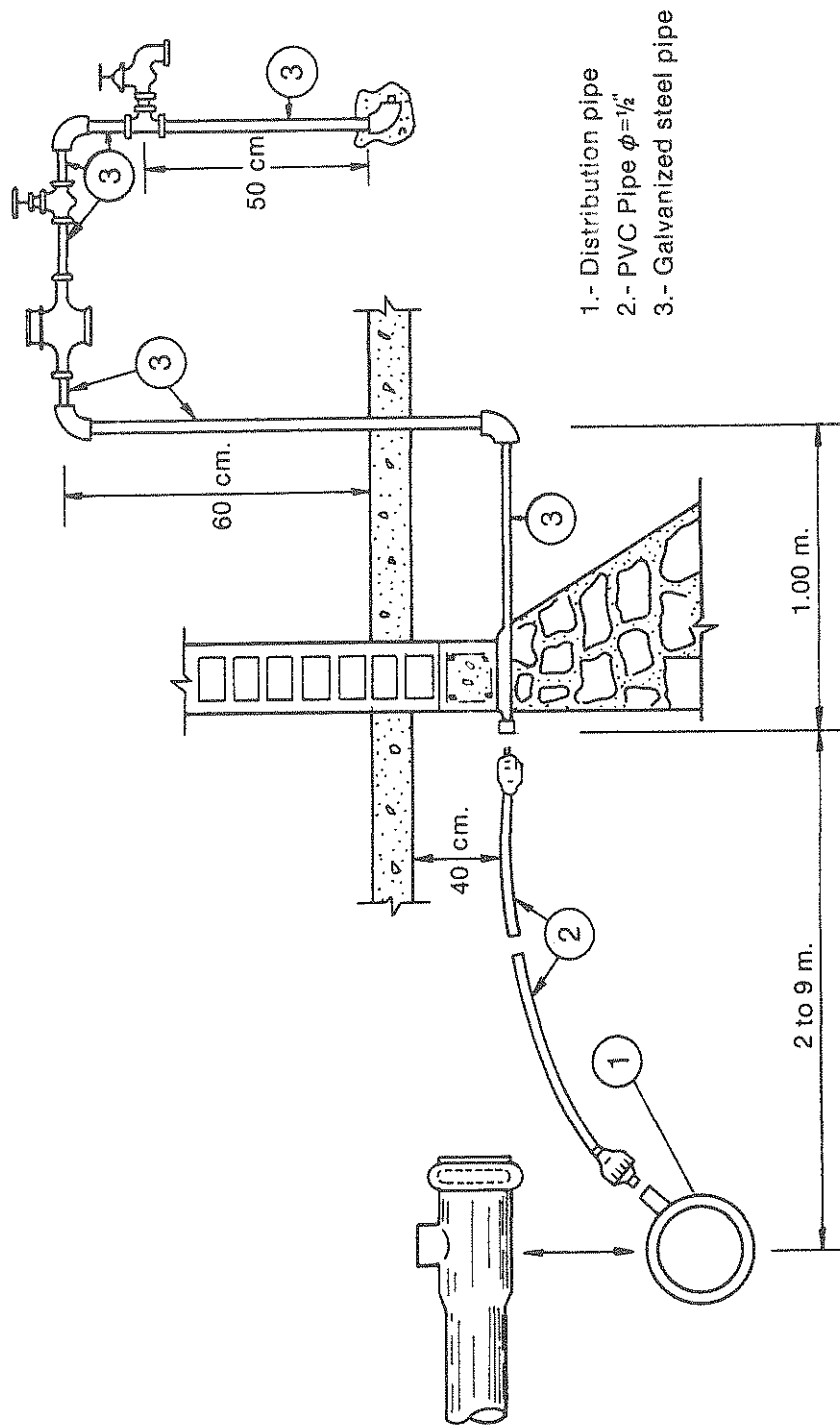

FIGURE 6-20 Typical Residential Service In The State Of Mexico (E.de.M.)

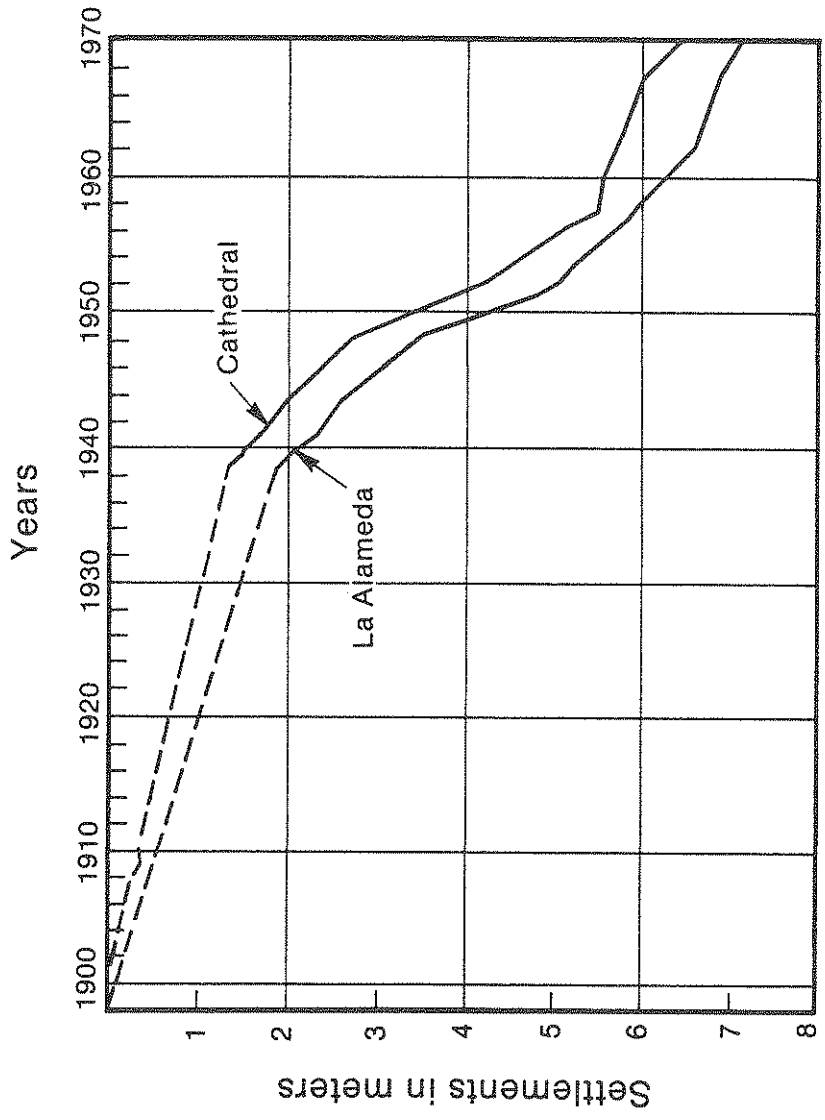

FIGURE 6-21 Settlement Vs. Time For Two Sites In Mexico City (After [5])

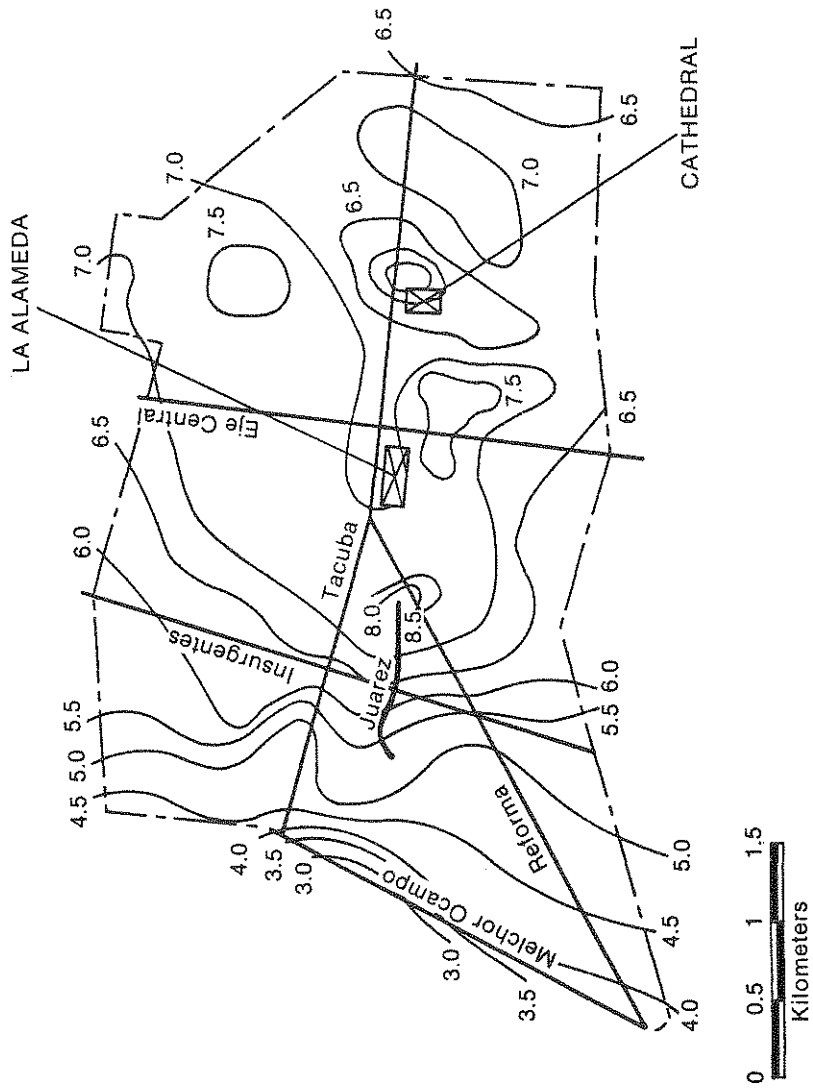

FIGURE 6-22 Contours Of Equal Subsidence In Old Mexico City As Of 1970 (After [5])

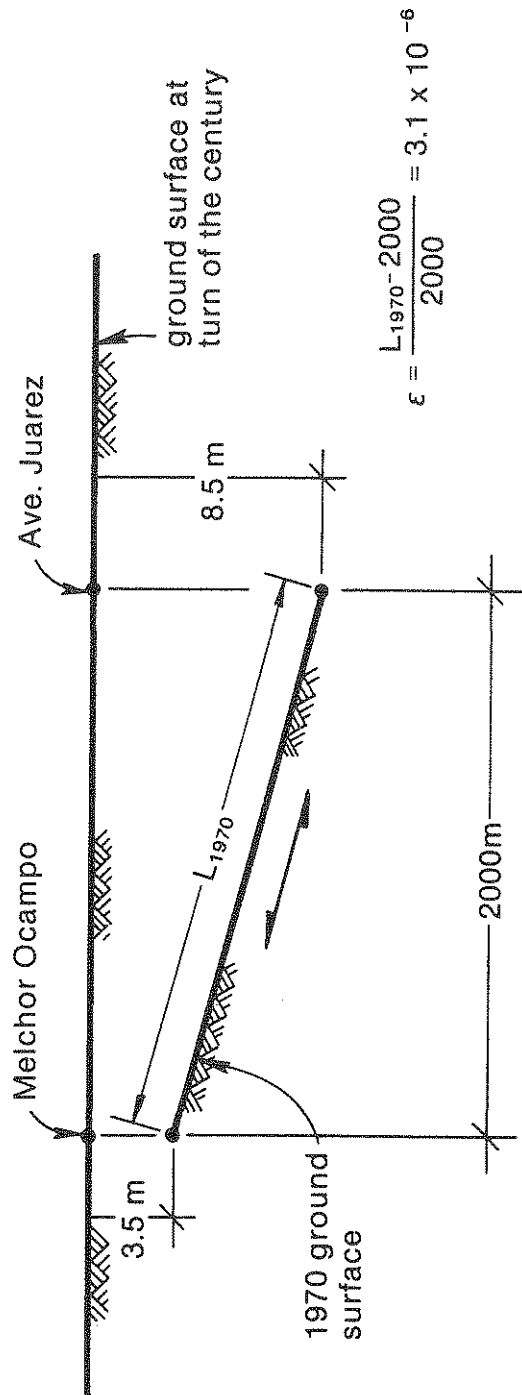

FIGURE 6-23 Ground Strain In Old Mexico City Due To Subsidence As Of 1970

system piping of Mexico City, it appears to be a second order effect vis-a-vis seismic wave propagation effects.

6.5 Comparisons with Other Earthquakes

Figure 6-24 shows data on pipe repairs versus peak ground acceleration, presented by Bresko [9], and based on damage data gathered by Katayama, [10]. Mexico City data for the Lake Zone is included in this figure. It can be seen that data from Mexico City falls within the band of damage data of other major earthquakes. Bresko suggests, based on these data, that failure rates can be expressed in terms of maximum ground acceleration as

$$\log N = A + 6.39 \log a_{\max} \dots \dots \dots (6.1)$$

where N is the number of repairs per kilometer, a_{\max} is the maximum ground acceleration and, A is a function of factors such as soil conditions, pipe age, etc., and is defined as 4.75, 3.65 and 2.20 for poor, average and good conditions respectively.

Theoretical analysis suggests that seismic wave propagation induced ground strain is proportional to peak ground velocity. Figure 6-25 presents the average damage ratios in Mexico City, per soil zone versus peak ground velocity. As one might expect, the peak ground velocities and damage ratios are high in the Lake Zone. However the damage ratio in the Transition Zone is somewhat higher than that in the Hill Zone although the peak ground velocities are comparable. This difference between Transition and Hill Zone damage ratios could be attributed to additional incoherence in ground motion in areas with changing soil types (such as the Transition Zone).

A graph of damage ratio for primary distribution piping vs pipe diameter is shown in figure 6-26. It may be observed that, as previously mentioned by Katayama [10] and others, damage ratio tends to be smaller as pipe diameter increases. Also, as expected, pipeline damage was larger in soft soils than in hard soils as may be observed from the data in table 6-VI.

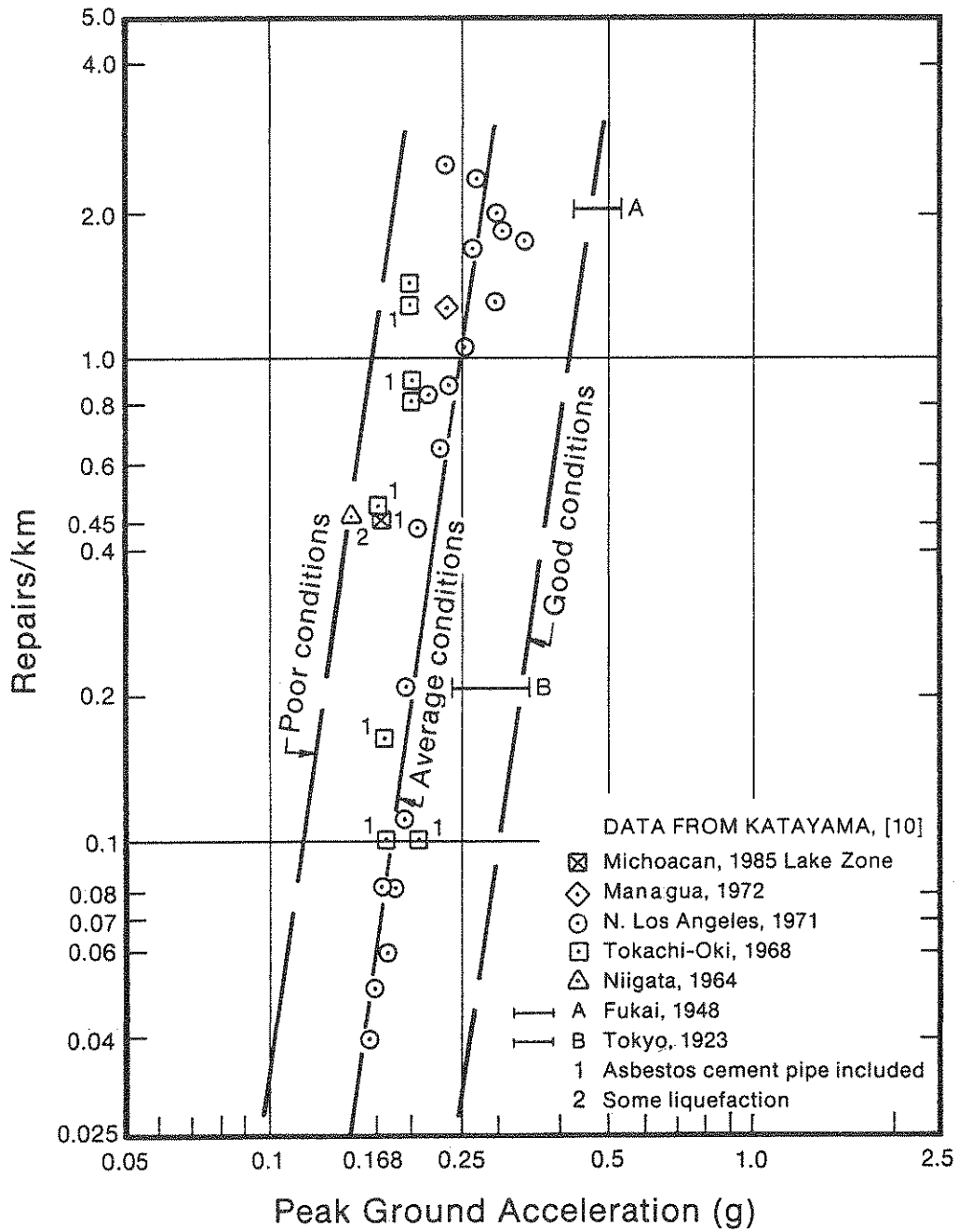

FIGURE 6-24 Pipe Repairs Per Km. Vs. Peak Ground Acceleration For Lake Zone In Mexico City 1985 And Other Historic Earthquakes

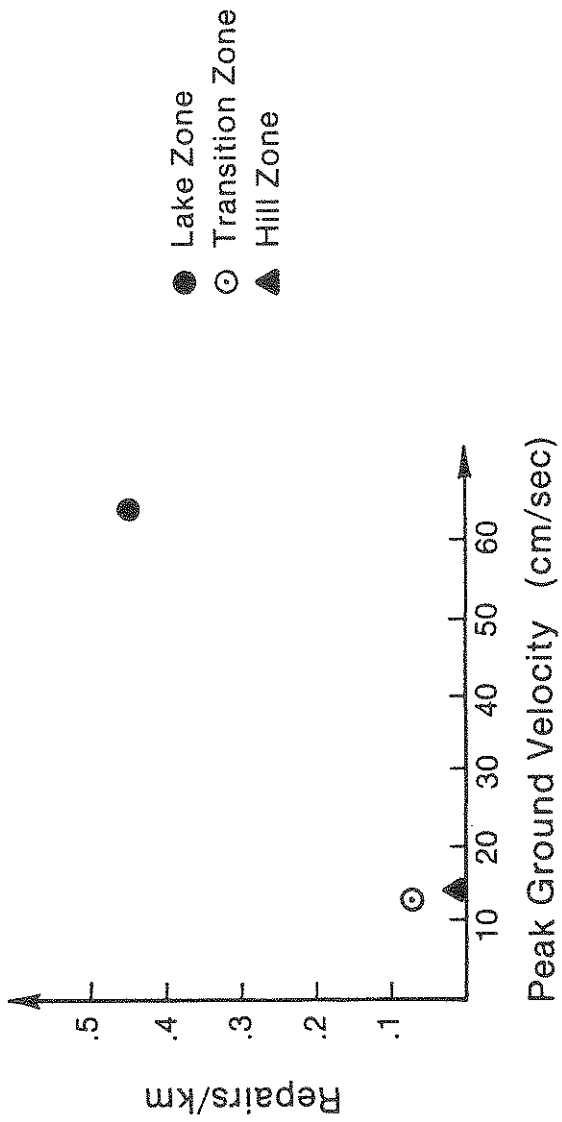

FIGURE 6-25 Damage Ratio Vs. Peak Ground Velocity, Mexico City 1985

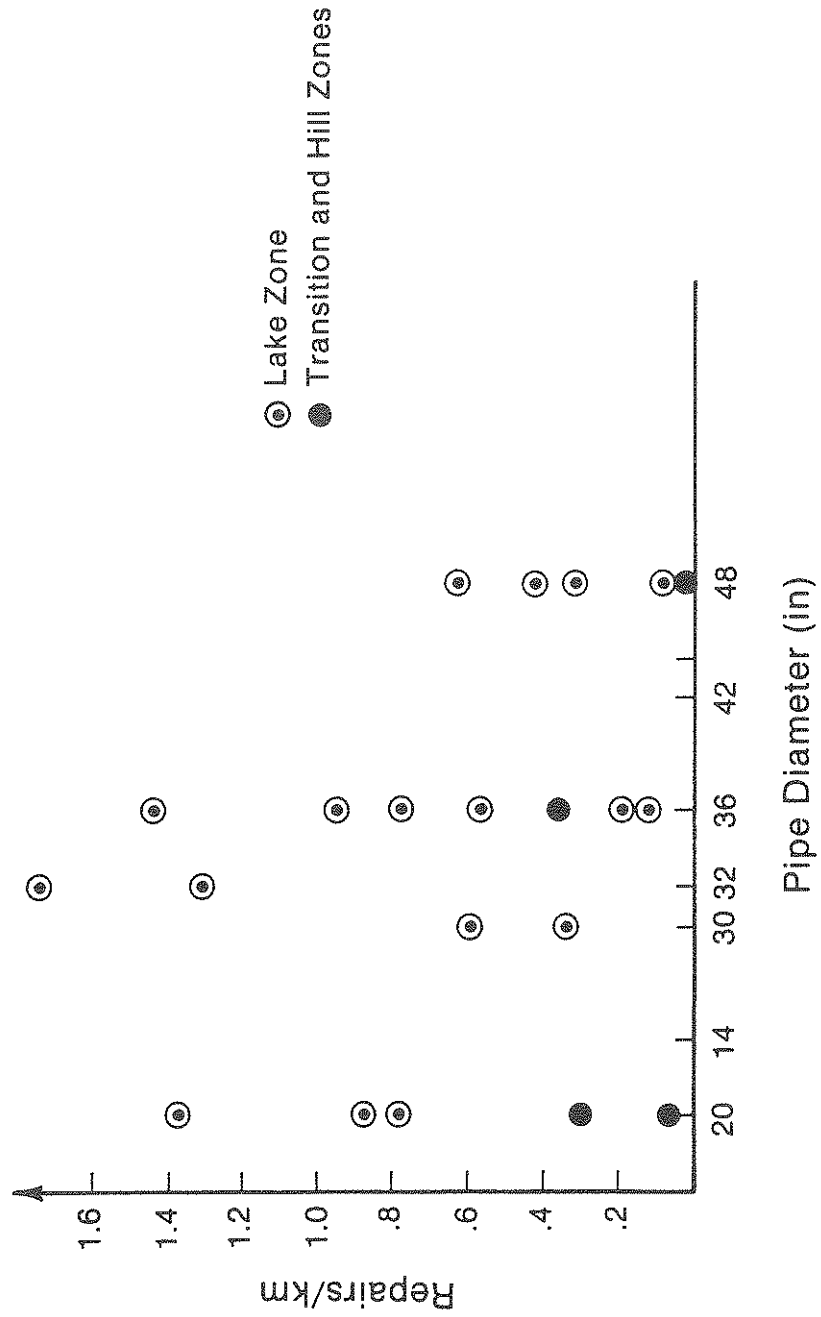

FIGURE 6-26 Damage Ratio Vs. Pipe Diameter, Mexico City 1985

TABLE 6-VI Damage Ratio And Maximum Ground Velocities For Different Soil Conditions

Zone	# Repairs km	Peak Ground Velocity V_{max} (cm/sec)		
		smallest value	average value	highest value
Lake	.45	36.1	48.0	64.1
Transition	.07	-	12.2	-
Hill	.01	-	11.45	14.3

SECTION 7
WELDED STEEL PIPELINE DAMAGE

In this section, a case study of damage to a welded steel pipeline in Mexico City caused by the 1985 Michoacan Earthquake is presented. The water pipeline in question is located in "Ciudad Nezahualcoyotl" in the state of Mexico. There are other welded steel pipelines in Mexico City operated by PEMEX, the state owned oil and gas company. However, the authors were unable to obtain information about seismic performance of PEMEX facilities.

Physical characteristics of the Ciudad Nezahualcoyotl water pipeline and information about the observed seismic damage is presented. In addition, an analysis procedure developed previously by the second author is used to estimate pipeline stress induced by seismic wave propagation. This estimated stress is slightly less than the local compressional buckling stress for the pipeline.

7.1 Physical Characteristics and Observed Damage

The Ciudad Nezahualcoyotl pipeline is the only major underground welded steel pipeline in the Metropolitan Mexico City water system. It is located in the State of Mexico, southeast of the airport and north of Cerro de la Estrella and runs parallel to Avenue Ignacio Zaragoza. The pipeline is about 9km in length and was constructed in the early 1970's of API 120 X-42 grade steel (yield stress = 42 ksi). The pipeline's diameter is 42 in. and it has a wall thickness of 5/16 in. The pipe centerline is about 6.35 ft. below the ground surface. At the time of the earthquake, the internal operating pressure was between 40 and 60 psi and the flow was about 1.6 m³/sec.

The subsoil profile for the general region consists of 40 m of very soft clay with a shear wave velocity (V_s) of about 40 m/sec. Below the top layer are two stiffer strata with thicknesses of 80m and 400m, and shear wave velocities of 300 m/sec and 500 m/sec respectively. These three layers sit atop rock with a shear wave velocity of about 1250 m/sec. This soil profile is shown in figure 7-1.

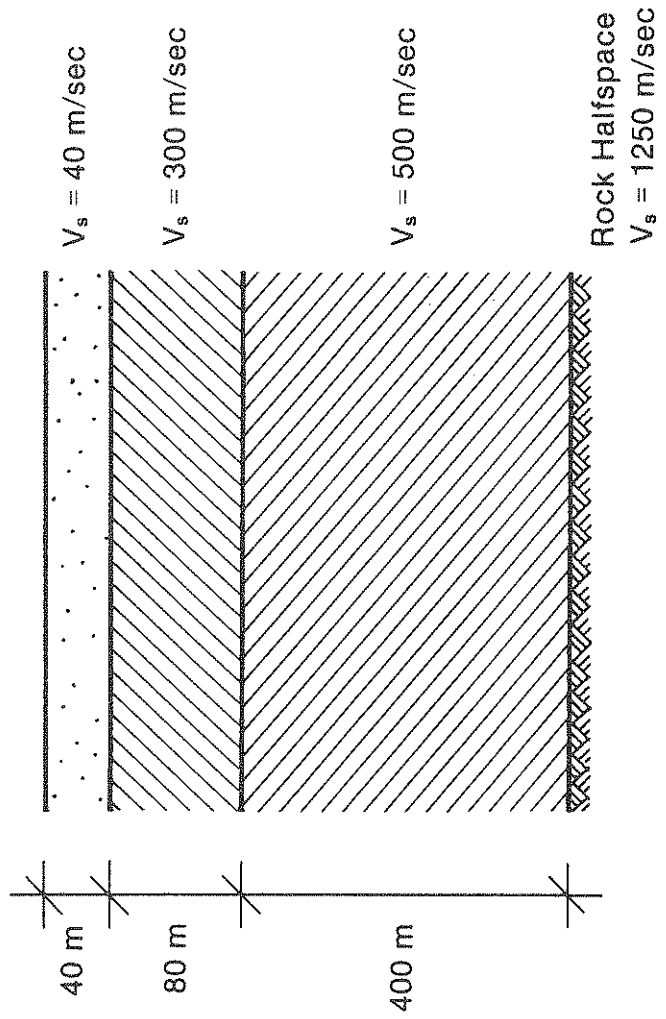

FIGURE 7-1 Estimated Soil Profile For Ciudad Nezahualcoyotl

Seismic damage occurred at a minimum of eight locations along the 9 km length of the line. At six of these points, circumferential cracks resulting from wrinkling deformations (ie, local buckling) were observed as shown in figures 7-2 and 7-3. In addition, a 36"φ butterfly valve located in an air relief valve box, was broken, as shown in figure 7-4. Breaks also occurred at a welded joint along the pipeline and on a 14"φ asbestos cement pipe connection to the steel pipeline. The locations of these failures are shown in figure 7-5. It is believed however that there were more failures than those shown in figure 7-5 since several engineers involved in the repair work reported that failures occurred consistently at 300 to 500 m intervals along the line. As mentioned previously, there was no evidence of liquefaction in the metropolitan area. In addition there was no evidence of permanent ground deformation in the metropolitan area, except for the previously mentioned subsidence. Hence it would appear that the seismic damage to the welded Ciudad Nezahualcoyotl pipeline as well as the other segmented pipelines in the water system was due to seismic wave propagation.

7.2 Stress Analysis

An analysis procedure developed by the second author [11] is herein used to estimate the compressive strain induced in the Nezahualcoyotl pipeline by seismic wave propagation. The procedure compares axial strain in the soil with the strain in a continuous pipeline due to soil friction along its length. It is assumed that the soil strain is due to Rayleigh Wave (surface wave) propagation along the pipeline axis. This soil strain is a decreasing function of separation distance or wavelength. The strain due to friction at the soil-pipeline interface is an increasing function of separation distance or wavelength. At a particular separation distance, that is for a particular wavelength, the friction strain matches the soil strain. This unique strain then becomes the peak strain induced in a continuous pipeline.

7.2.1 Soil Strain

The maximum horizontal strain in the soil is based upon the assumption of a Rayleigh wave (R-wave) propagating in the direction of the pipeline axis. This longitudinal soil strain ϵ_s between two sites separated by a distance L

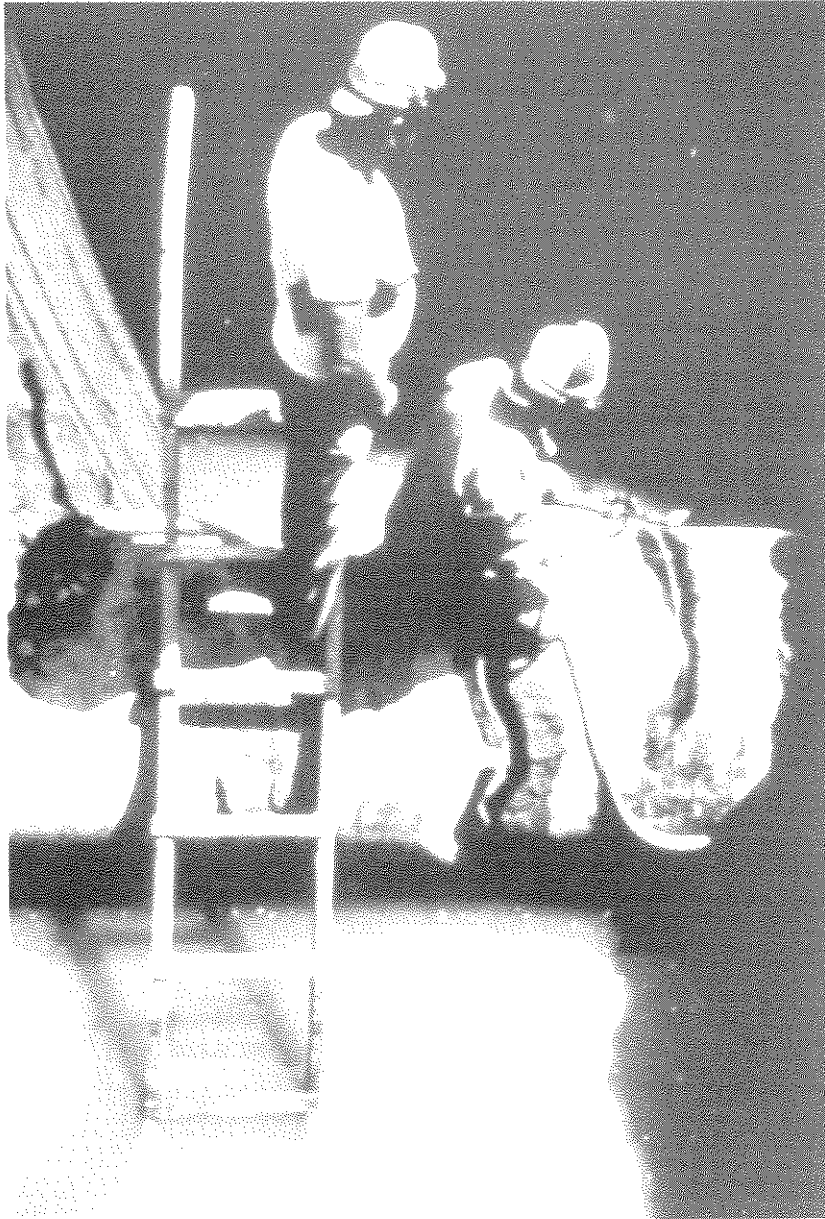

FIGURE 7-2 Local Buckling Failure Of Ciudad Nezahualcoyotl Pipeline - 1985
Michoacan Earthquake

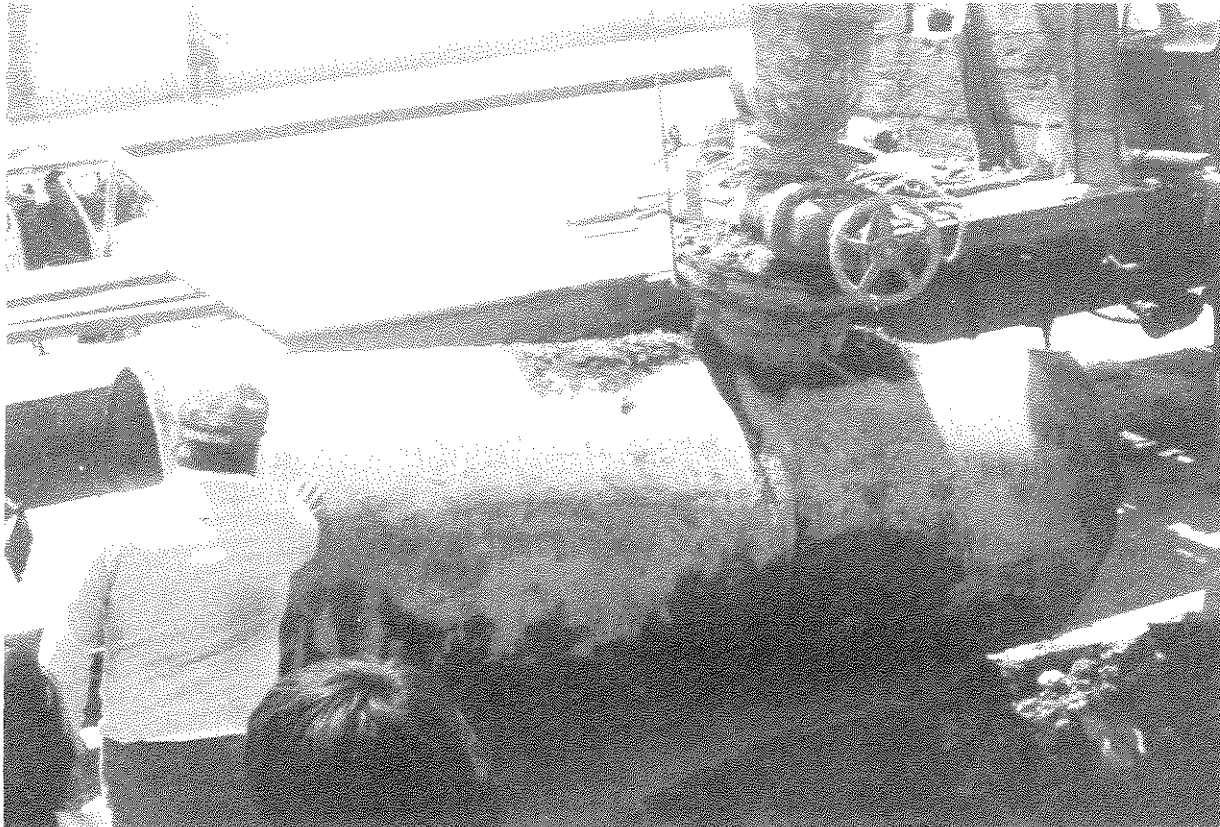

FIGURE 7-3 Wrinkling Deformation Close To A Valve Location, Ciudad Nezahualcoyotl Pipeline, 1985 Michoacan Earthquake



FIGURE 7-4 Broken Butterfly Valve

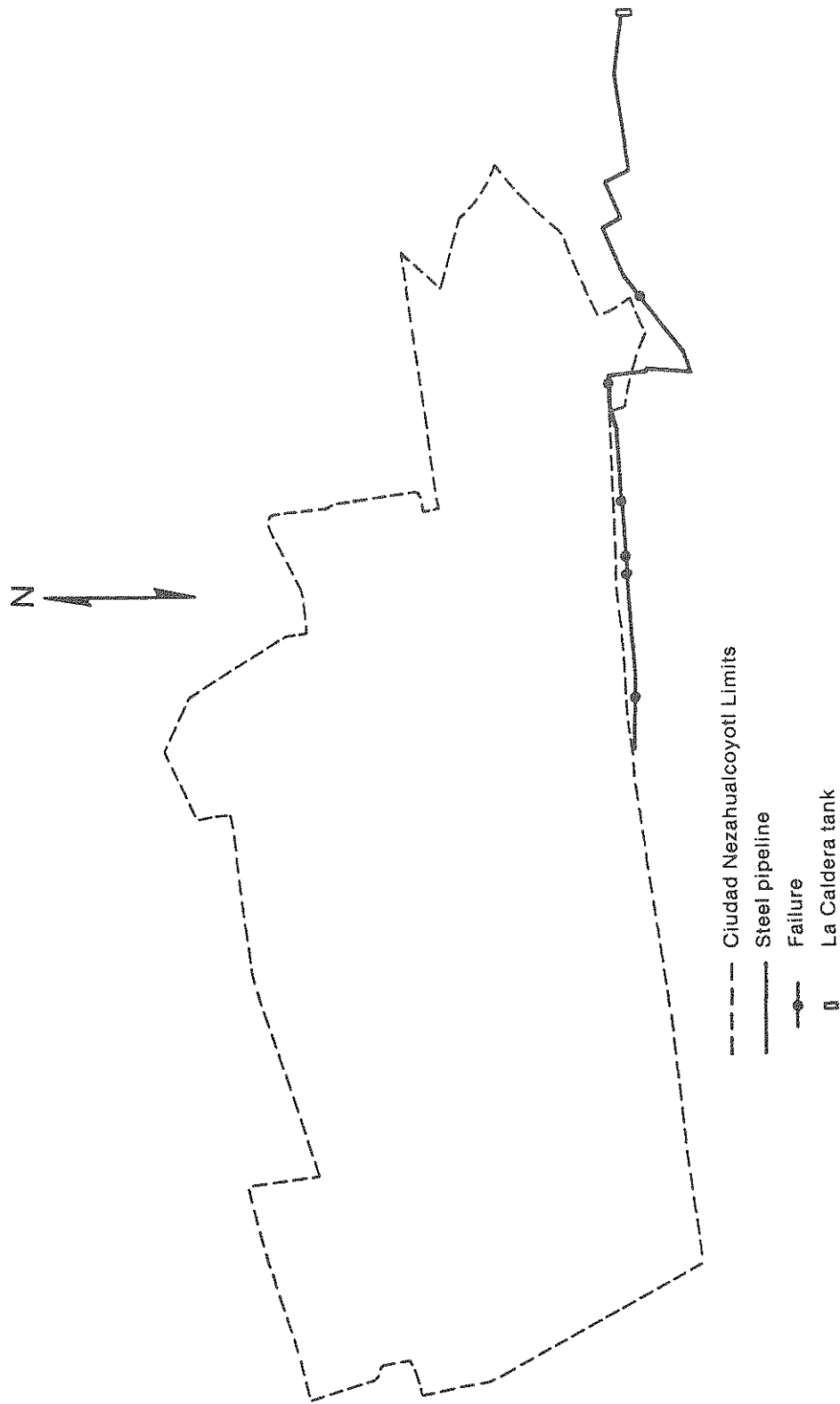

FIGURE 7-5 Reported Failures Along Steel Pipelines In Ciudad Nezahualcoyotl (E.de.M.) in 1985

is given by

$$\epsilon_s = V_{\max}/C \dots \dots \dots (7.1)$$

when V_{\max} is the peak ground velocity in the region and C is the appropriate phase velocity of the R-wave. Using empirical data from the 1971 San Fernando Earthquake, O'Rourke, Castro and Hossain [12] have shown that the appropriate R-wave phase velocity has a wavelength equal to four times the separation distance. That is, equation (7.1) gives the ground strain over a quarter wavelength separation distance.

The two stations closest to Ciudad Nezahualcoyotl are Central de Abastos-Frigorifico and Central de Abastos-Oficinas. Like Ciudad Nezahualcoyotl, both the Central de Abastos station are located in the Lake Zone. The plausability of R-wave propagation near Central de Abastos is shown in figures 7-6 and 7-7. These figures show the North-South and East-West velocity time histories at both Central de Abastos-Oficinas (Lake Zone) and at Ciudad Universitaria - Laboratories (Hill Zone). Notice in these Hill Zone records, the peak ground velocities are about 10 cm/sec and the ground motion dies out about 60 seconds after initial triggering of the recording devise. In the Lake Zone records, the ground velocities during the first 30 or 40 sec. after initial triggering are roughly about 10 cm/sec. However the peak ground velocities of 30 or 40 cm/sec occur between a minute and two and a half minutes after initial triggering. This suggests that R-waves could well have been present near Central de Abastos. Note that if R-wave are present, they occur after the arrival of the direct body waves.

As shown in table 5-I, the peak horizontal ground velocities at the two Central de Abastos stations were 24.8, 37.6, 35.0 and 41.9 cm/sec. It is assumed herein that V_{\max} for the Ciudad Nezahualcoyotl site is the average of the Central de Abastos values or 34.8 cm/sec.

In order to determine the soil strain by equation 7-1, one needs a R-wave dispersion curve (plot of phase or propagation velocity versus frequency) for the site. A computer program based upon a procedure developed by Schwab and Knopoff [13] was used herein. For the Ciudad Nezahualcoyotl soil profile in

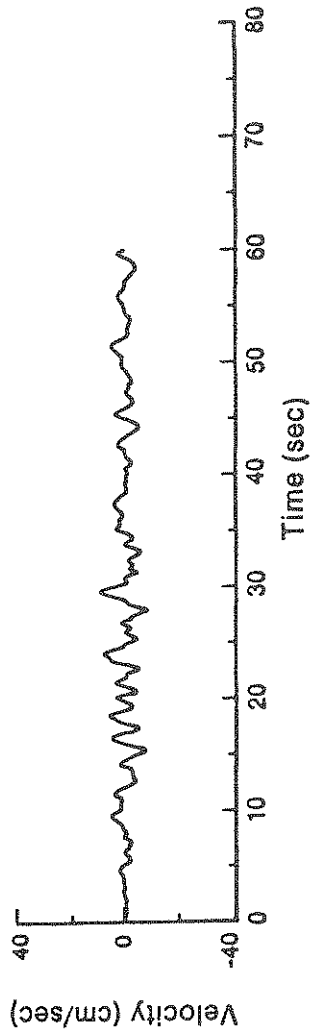

a) Ciudad Universitaria - Lab. (Hill Zone)

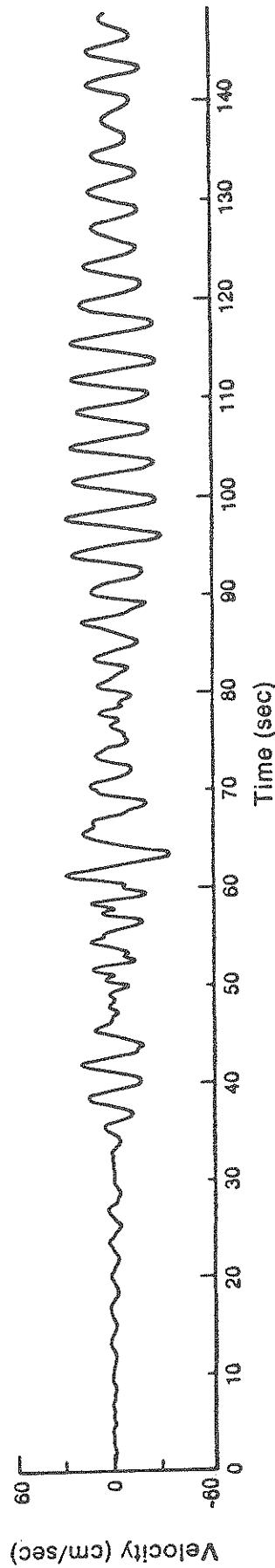

b) Central de Abastos - Oficinas (Lake Zone)

FIGURE 7-6 North-South Velocity Time Histories In Hill And Lake Zones Of Mexico City - 1985 Michoacan Earthquake

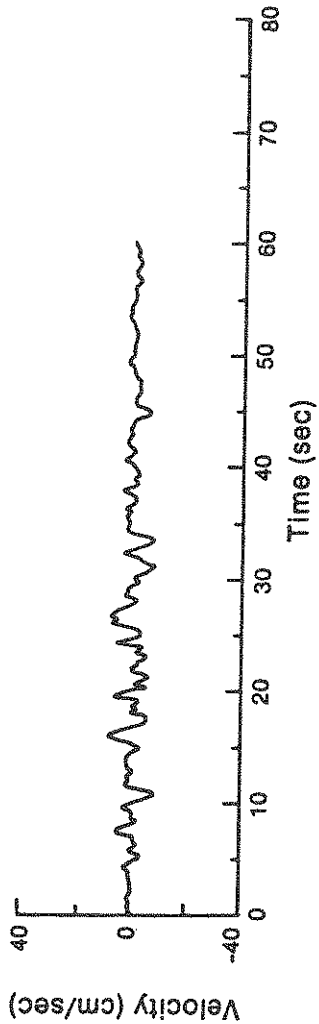

a) Ciudad Universitaria - Lab. (Hill Zone)

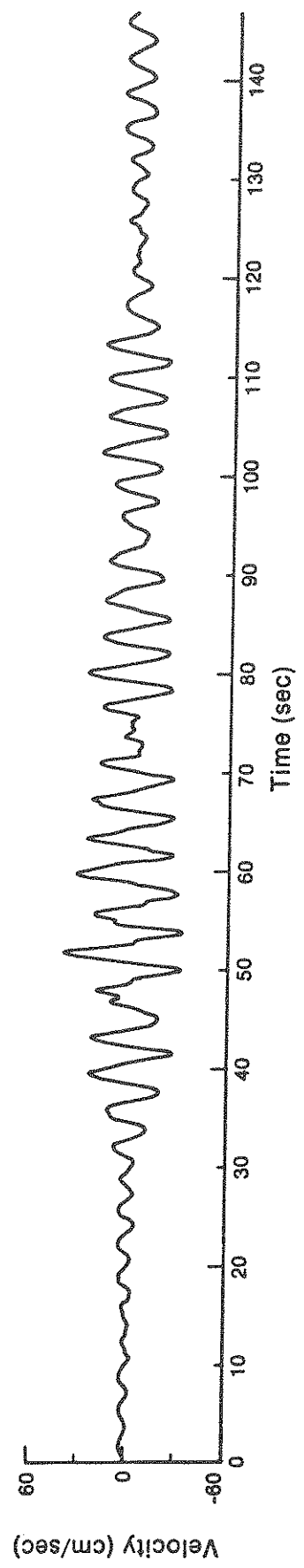

b) Central de Abastos - Oficinas (Lake Zone)

FIGURE 7-7 East-West Velocity Time Histories In Hill And Lake Zones Of Mexico City - 1985 Michoacan Earthquake

figure 7-1, the resulting R-wave dispersion curves for Poisson ratios (ν) of 0.25 and 0.48 are shown in figure 7-8. Notice for low frequencies (long wavelengths) the R-wave phase velocity is close to the shear wave velocity of the rock half space while at high frequencies (short wavelengths) the phase velocity is close to V_s for the soft top layer.

Having the R-wave dispersion curve plot of phase velocity versus frequency, the ground strain as a function of separation distance can be generated by equation 7.1. This calculation is presented in table 7-I and utilizes the relationship between phase velocity C , wavelength λ and frequency f ;

$$C = \lambda \cdot f \dots \dots \dots (7.2)$$

The variation of soil strain ϵ_s with quarter wavelength separation distance is shown in figure 7-9 for an assumed Poissons ratio of 0.48. Note that the ground strain is a decreasing function of the quarter wavelength separation distance.

7.2.2 Frictional Strain

Strain in the pipeline is induced by friction at the soil pipeline interface. The friction force per unit length f_m at this interface is taken as the coefficient of friction times the product of the average overburden pressure and the circumference

$$f_m = \mu \cdot \gamma \cdot z \left(\frac{1+k_0}{2} \right) \pi D \dots \dots \dots (7.3)$$

when μ is the coefficient of friction, γ is the unit weight of the soil, z is the burial depth, k_0 is the coefficient of lateral earth pressure and D is the outside diameter of the pipe.

For a ground wave with wavelength λ , the points of zero ground strain are separated by $\lambda/2$. The maximum friction force which such a wave could induce in a pipeline is the friction force per unit length times a quarter wavelength.

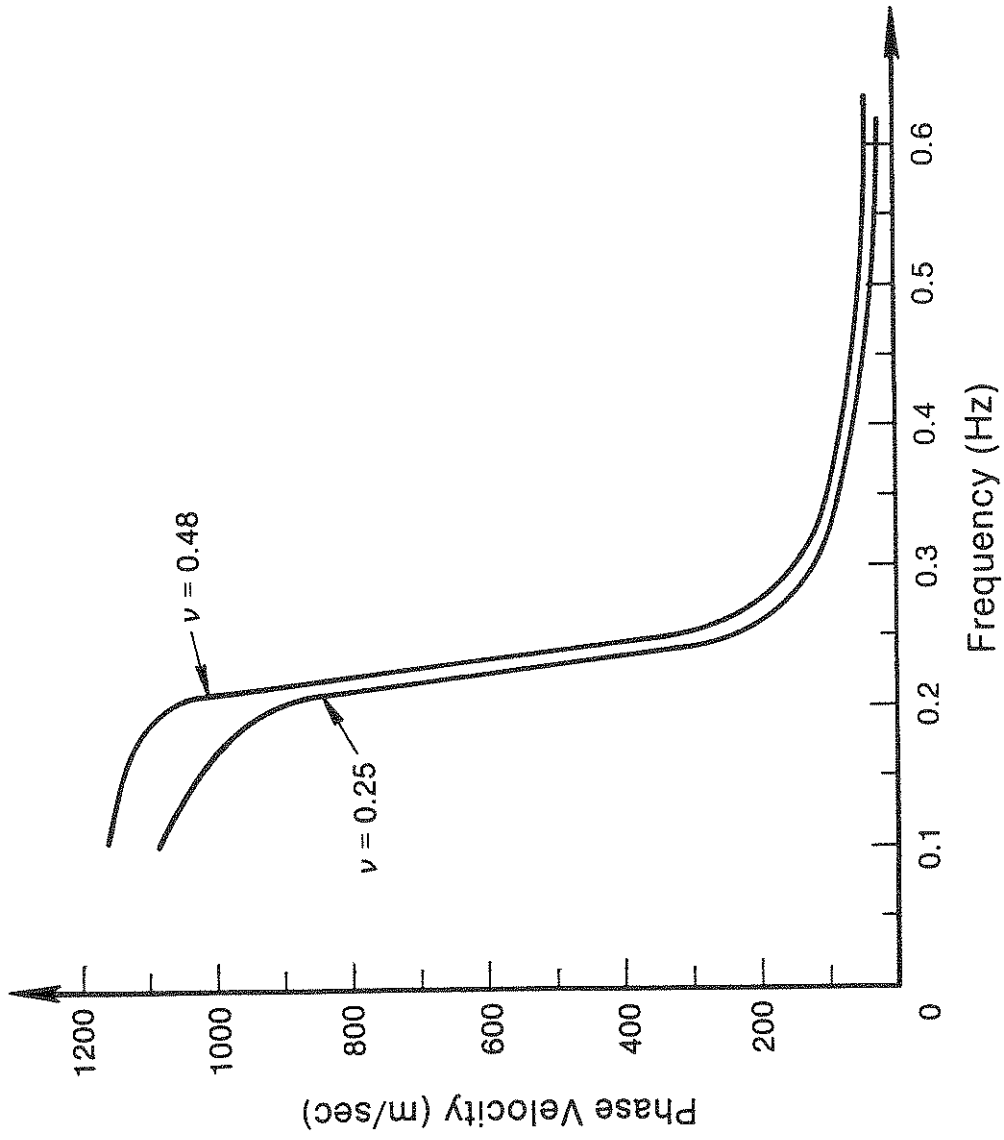

FIGURE 7-8 R-wave Dispersion Curve For Ciudad Nezahualcoyotl Site

TABLE 7-I Calculation Of Soil Strain Vs. Quarter Wavelength Separation Distance For Ciudad Nezahualcoyotl Site

Frequency f (hz)	Phase Velocity C (m/sec)	Wavelength $\lambda = C/f$ (m)	Quarter Wavelength Separation Distance $L = \lambda/4$ (m)	Soil Strain $\epsilon_s = V_{\max}/C$
0.15	1140	7600	1900	.0003
0.20	1110	5550	1388	.0003
0.25	330	1320	330	.00105
0.30	137	456	114	.0025
0.35	107	306	76.5	.00325
0.40	91.6	229	57	.0038

$$F_{\max} = f_m \lambda / 4 \dots \dots \dots (7.4)$$

Hence the maximum pipeline stress σ_f due to friction at the soil-pipeline interface becomes

$$\sigma_f = \frac{F_{\max}}{A} = \mu \gamma z \left(\frac{1+k_o}{2} \right) \frac{\pi D \lambda}{4A} \dots \dots \dots (7.5)$$

where A is the cross sectional area of the pipeline. At shorter quarter wavelength separation distances, the pipeline frictional stress σ_f is low, the material is linearly elastic and the pipeline frictional strain ϵ_f is linearly proportional to the quarter wavelength separation distance. However at longer quarter wavelength separation distances, ϵ_f is no longer proportional to $\lambda/4$ because of nonlinear material behavior at high stress. Modeling the API 120 x-42 steel as a Ramberg-Osgood material with shape parameter $n=15$, the frictional pipeline strain is plotted as a function of the quarter wavelength separation distance in figure 7-9. In this plot, the known values for the cross sectional area A, the buried depth z and the pipe diameter are used. In addition the coefficient of friction μ is taken as 0.5, the unit weight of the soil γ is taken as 110 lbs/ft³, and the coefficient of lateral earth pressure k_o is taken as 1.0.

The actual maximum pipeline strain is the smaller of the ground strain ϵ_g or the frictional strain ϵ_f . Note for a quarter wavelength separation distance of about 130m, $\epsilon_g = \epsilon_f$ and hence the actual maximum pipe strain is about 0.0023 by the procedure described above. Again using a Ramberg-Osgood model with shape parameter $n=15$ for the API 120x-42 material, the corresponding actual maximum pipeline stress is about 40.9 ksi.

As mentioned previously, the observed locations of compressional wrinkling were at 300 to 500 meter spacings. Note that at any particular instant in time, the procedure described above suggests that areas of high compressive stress would occur at a spacing of about 520m. That is high compression regions are a wavelength apart, or 520m for the critical quarter wavelength of 130m.

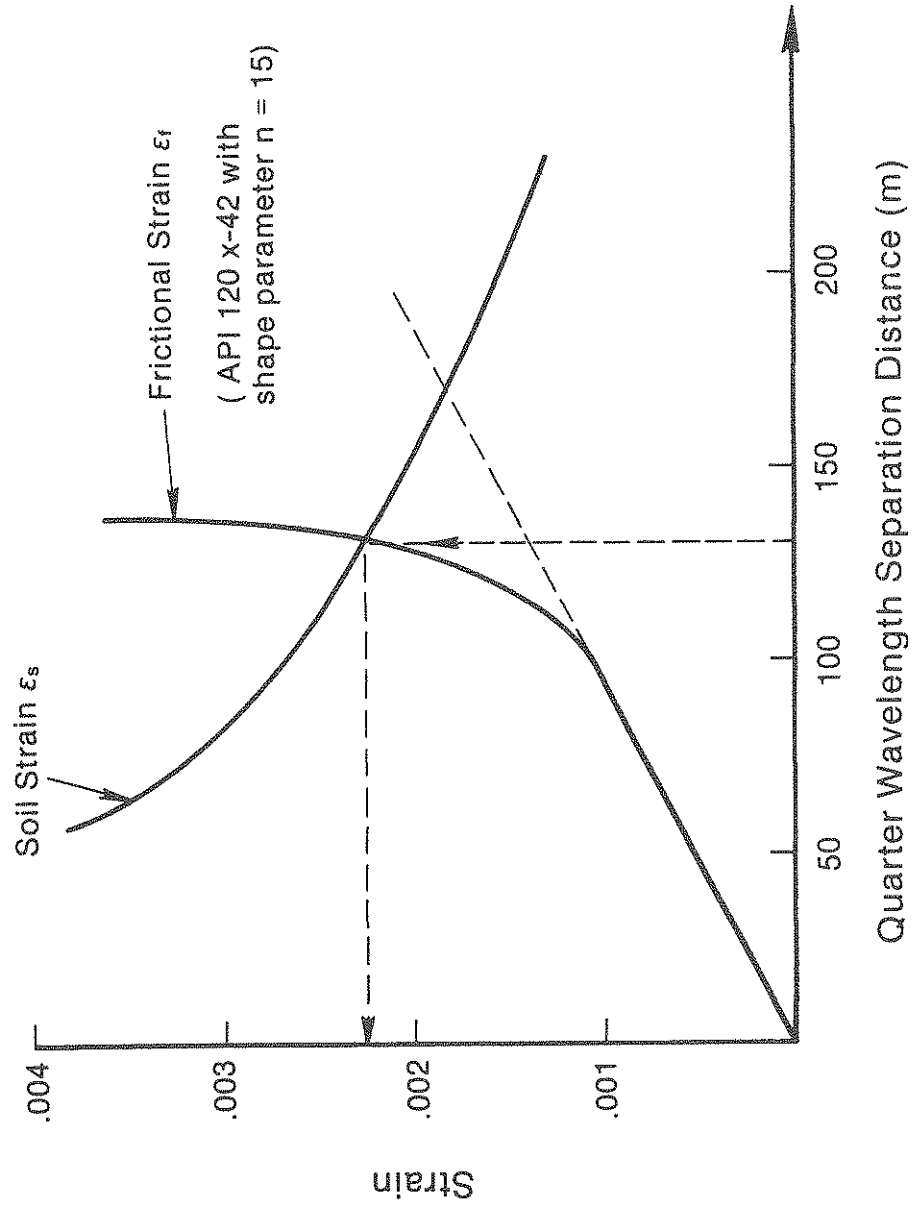

FIGURE 7-9 Soil And Friction Strain For Ciudad Nezahualcoyotl Pipeline

7.3 Critical Local Buckling Stress

As noted by Schilling (14), the critical compressive stress for local buckling of a unpressurized thin circular cylinder in air is

$$\sigma_{cr} = a \cdot c \cdot E \cdot t / R \dots \dots \dots (7.6)$$

where t is the wall thickness, R is the pipeline radius, E is Youngs Modulus, c is a local buckling in perfection parameter and a is a plasticity reduction factor. The local buckling imperfection parameter is plotted in Schillings paper as a function of the radius to thickness ratio R/t. For the pipeline in question $R/t = 67.2$ for which $c = 0.46$.

The plasticity reduction term is defined as

$$a = 1.10 \sqrt{\frac{E_s \cdot E_t}{E^2}} \dots \dots \dots (7.7)$$

where E_s and E_t are the secant and tangent modulus for the level of stress in question. Relationships for E_s and E_t in terms of E are given below.

$$\frac{E}{E_s} = 1 + \frac{3}{7} \left(\frac{\sigma}{\sigma_{0.7}} \right)^{n-1} \dots \dots \dots (7.8)$$

and

$$\frac{E}{E_t} = 1 + \frac{3n}{7} \left(\frac{\sigma}{\sigma_{0.7}} \right)^{n-1} \dots \dots \dots (7.9)$$

where $\sigma_{0.7}$ is the stress corresponding to the intersection of the 0.7E secant modulus line with the actual stress-strain curve. For API 120 x-42 steel, $\sigma_{0.7}$ is approximately 39.3 ksi.

Since the plasticity reduction factor is a function of the level of stress, an iterative procedure must be used to solve for the critical buckling stress. For an unpressurized API 120 x-42 with $t=5/16$ in and $R=21$ in, a number of

trials yields 41.4 ksi as the critical local buckling stress. Note that this value falls in the range of experimental values as reported by Schilling (14).

The Ciudad Nezahualcoyotl pipeline was pressurized. The effective internal pressure ρ on the pipeline, internal gage pressure minus overburden pressure, was about 45 psi. Internal pressure has the effect of increasing the local buckling stress. Harris et.al. (15) show that for moderate values of the normalized internal pressure $\frac{\rho}{E} (R/t)^2$, the percentage increase in the local buckling stress for a unstiffened circular cylinder is linearly proportional to the normalized internal pressure. Specifically, the percentage increase in buckling stress is zero for zero internal pressure and is about 61% for a normalized internal pressure $\frac{\rho}{E} (R/t)^2 = 0.169$ and above. For the pipeline in question, the normalized internal pressure is 0.007 which would correspond to about a 3% increase in the buckling stress. That is, considering the effective internal pressure in the Ciudad Nezahualcoyotl pipeline, the estimate local buckling stress for the pipeline in an $41.4 \text{ ksi} \times 1.03 = 42.6 \text{ ksi}$.

The local buckling stress presented above is for a circular cylinder in air, while the pipeline in question was buried. That is, the passive resistance of the surrounding soil has been neglected. The authors feel that this is a reasonable assumption since, as shown in Figure 7-2, the volume of soil mobilized by local buckling would be quite small.

In summary, the compressive stress in the pipeline due to R-wave propagation is estimated to be about 40.9 ksi while the local buckling stress is estimated to be about 42.6 ksi. That is, this analysis procedure suggests that the pipeline was very close to buckling. Given the scatter between predicted and observed buckling stresses presented by Schilling (14) it is not surprising that the pipeline did, in fact, suffer a local buckling failure.

7.4 Case Study Summary

Because of the lack of liquefaction or permanent ground displacement, it is clear that the observed compressional wrinkling of the Ciudad Nezahualcoyotl

pipeline was due to seismic wave propagation. Recorded ground motion at the station closest to the pipeline suggest the presence of surface waves in this area of the Lake Zone.

A previously developed analysis procedure based upon the assumption of R-wave propagation results in estimated pipeline stress slightly below the estimated local buckling stress for the API 120 x-42 pipe yield stress.

. It should be mentioned that wave propagation damage to a modern welded steel pipeline is unusual. In the past, earthquakes have caused damage to other continuous steel pipeline but the damage mechanisms in those cases have been relative displacement at a fault, permanent ground displacement due to liquefaction, or pin hole leaks in a pipe previously weakened by corrosion. The authors believe that the Nezahualcoyotl pipeline is the only reported case of seismic wave propagation to a corrosion free modern continuous steel pipeline.

The authors believe there are three factors which make this case somewhat unique. That is, the factors listed below help explain why the Ciudad Nezahualcoyotl pipeline was damaged while earthquakes in other parts of the world have apparently not resulted in seismic wave propagation damage to modern continuous steel pipeline.

- o R-waves; it appears that R-waves were present at the Nezahualcoyotl site, whereas they are not always present in other ground motion records.

- o Peak Ground Velocity; V_{max} is the ground motion parameter which controls ground strain due to wave propagation. The peak ground velocity near the Nezahualcoyotl site was about 35 cm/sec. This value is large in absolute terms and is particularly large in comparison to the recorded peak accelerations of about 80 gals. Note Newmark [16] presents $122 \frac{\text{cm/sec}}{\text{g}}$ as a typical value for the ratio of peak ground velocity to peak ground acceleration in alluvium. Using Newmark's value, a peak ground acceleration of about 300 gals would "typically" be associated with a V_{max} value of 35 cm/sec in alluvium.

o Soft Soil Layer; Ground strain is inversly proportional to the propagation velocity of the seismic waves. The soil in the Lake Zone is particularly soft with the top layer having a propagation velocity of only 40 m/sec.

SECTION 8
DAMAGE TO OTHER BURIED LIFELINES IN METROPOLITAN MEXICO CITY

In this section, observed seismic damage to other buried lifelines in Metropolitan Mexico City is discussed. Minor damage occurred in the underground Metro tunnels and stations and in the sewer system. It is concluded that the lack of significant seismic damage to the Metro System may be attributed in part to its larger burial depth as compared with that of the water systems. For the sewer system, the lack of observed damage can be attributed to burial depth effects as well as difficulty in recognizing damage in a unpressurized system.

8.1 Sewer System Damage

The 1985 Michoacan Earthquake caused minor damage to the sewer system of Mexico City. Worth mentioning are several fractures in the main pipeline that collects wastewater from areas in the southeast part of the city. Fractures also occurred in collectors that discharge into the 'Gran Canal' and at construction joints along 6.5 km of a cast-in-place line known as the 'Rio de la Piedad' which is located in the Lake Zone. Preliminary information indicates that the fracture's in the cast-in-place line were equally spaced as was observed in the continuous steel pipeline in Ciudad Nezahualcoyotl, previously discussed in section 7. In the State of Mexico, damage was reported in the shaft of a 36" pump located at a waste and runoff water pumping facility known as Pumping Station #2.

All the reported sewer damage occurred in areas where water pipelines were also damaged. The difference between the amount of sewer system damage compared to the amount of water system damage can be attributed to two factors.

- 1) For obvious health reasons, sewer lines are buried deeper than water lines. Since seismic motion decreases with depth below the surface, sewer lines experience somewhat less seismic deformation than water lines.
- 2) Gravity flow sewer lines are not pressurized while water pipelines are pressurized. Significant joint extension or crushing at the bell

in a pressurized line will result in a leak which is eventually evidenced by water of the ground surface. However, for a gravity flow sewer line, significant joint extension or bell crushing may never manifest itself at the ground surface.

Hence, because of the difference in burial depth between sewer and water lines, actual sewer system damage was probably somewhat less than the actual water system damage. In addition, because of difficulties in detecting sewer system damage the observed water system damage was many times greater than the observed sewer system damage.

8.2 Underground Metro Damage

Some of the underground installations most carefully inspected after the earthquake were the Metro tunnels and stations. This inspection revealed only minor cracks at junctions between stations and tunnels, and at sites with drastic changes in stiffness (e.g. near ventilation shafts.) The Metro subway system could have been operated immediately after the earthquake if power was available. It had been thought that underground Metro installations were possibly the cause of above ground building damage. However both damage statistics and an analytical study [17] showed that the Metro tunnels did not have a significant effect upon the distribution and intensity of damage to above ground structures in the city.

SECTION 9
WATER SYSTEM DAMAGE IN EPICENTRAL AREA

In this section water system damage in the epicentral region of the 1985 Michoacan earthquake is described. Information on all reported failures is presented.

9.1 Observed Damage

In contrast to the heavy damage experienced by the Mexico City water systems, water supply in the epicentral region was lightly damaged. In the industrial part of Lazaro Cardenas, wells, above ground pipelines and buried pipelines were damaged. The locations of water system damage in the epicentral region is shown in figure 9-1. Presented below is a description of the specific damage.

a. Damage to wells:

Earthquake induced soil subsidence caused wells shaft to emerge from the ground surface. As shown in figure 9-2 this relative upward movement of the well shaft resulted in damage to the valve system and the pipes connecting to it

b. Damage to above ground pipelines:

Seismic wave propagation caused joint pull-out and misalignment damage to a 72"φ above ground reinforced concrete pipeline. This damage is shown in figure 9-3.

c. Damage to Buried Pipelines:

The 72"φ reinforced concrete pipeline mentioned above in (b) was buried over part of its length. Seismic damage along the buried portion of this line occurred near a thrust block.

It should be mentioned that the epicentral region experienced liquefaction with accompanying significant ground movements. However, water supply

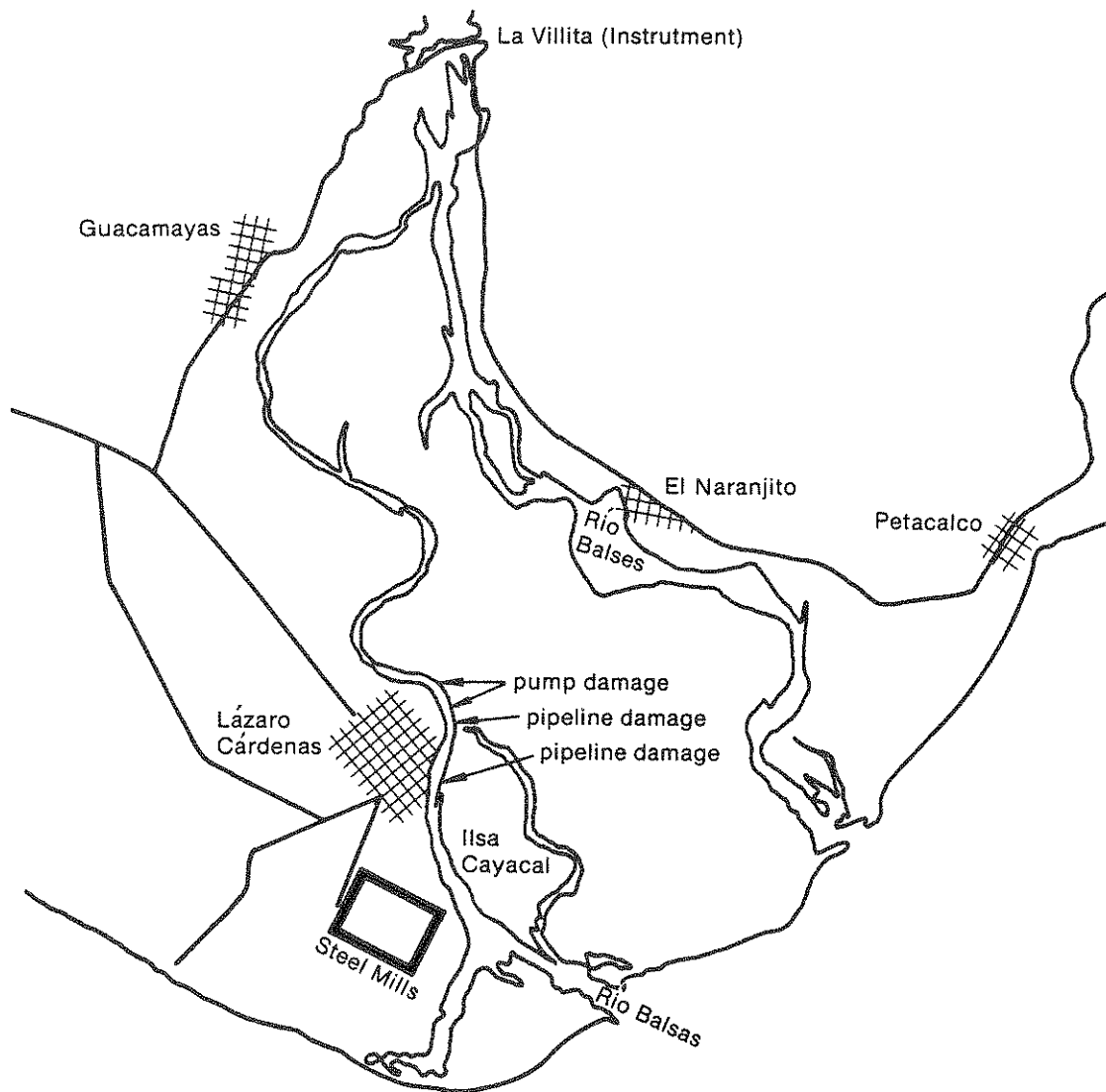

FIGURE 9-1 Water System Damage In Epicentral Region - 1985 Michoacan Earthquake

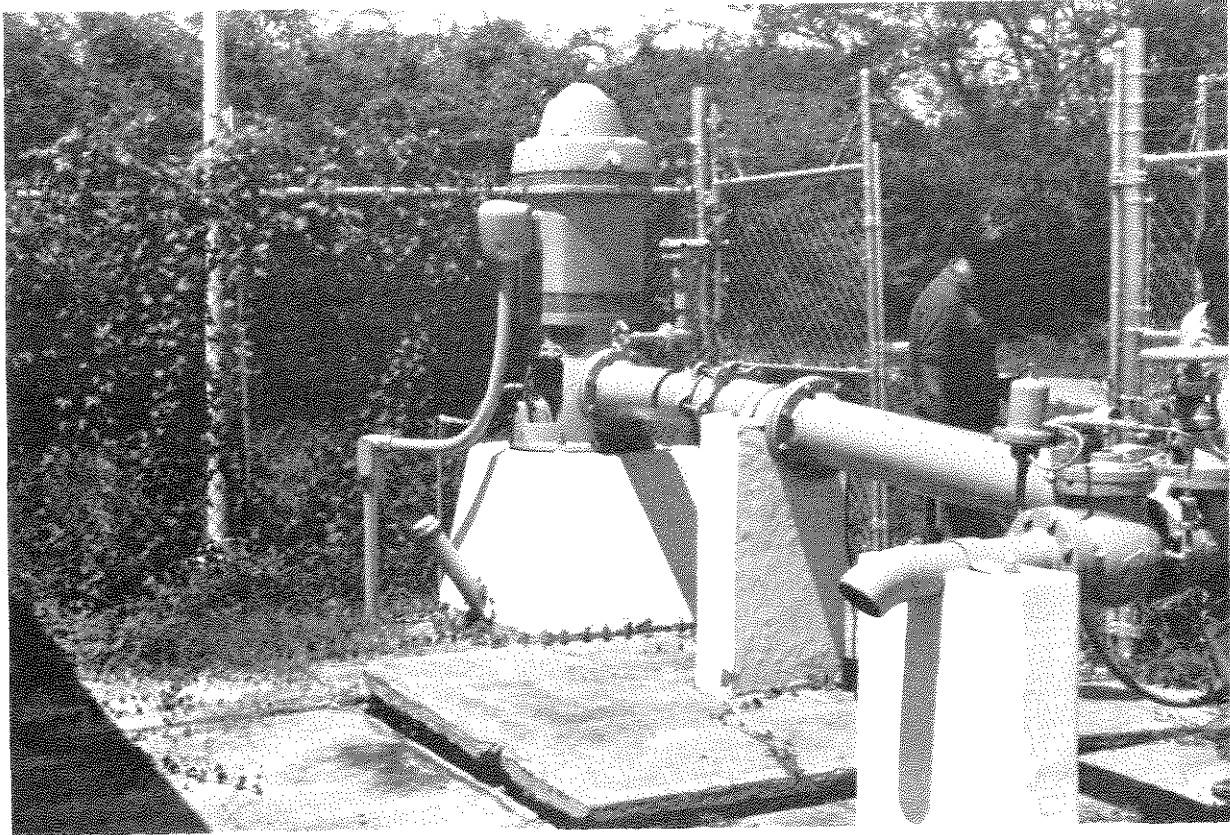

FIGURE 9-2 Damage To A Well, Epicentral Region - 1985 Michoacan Earthquake

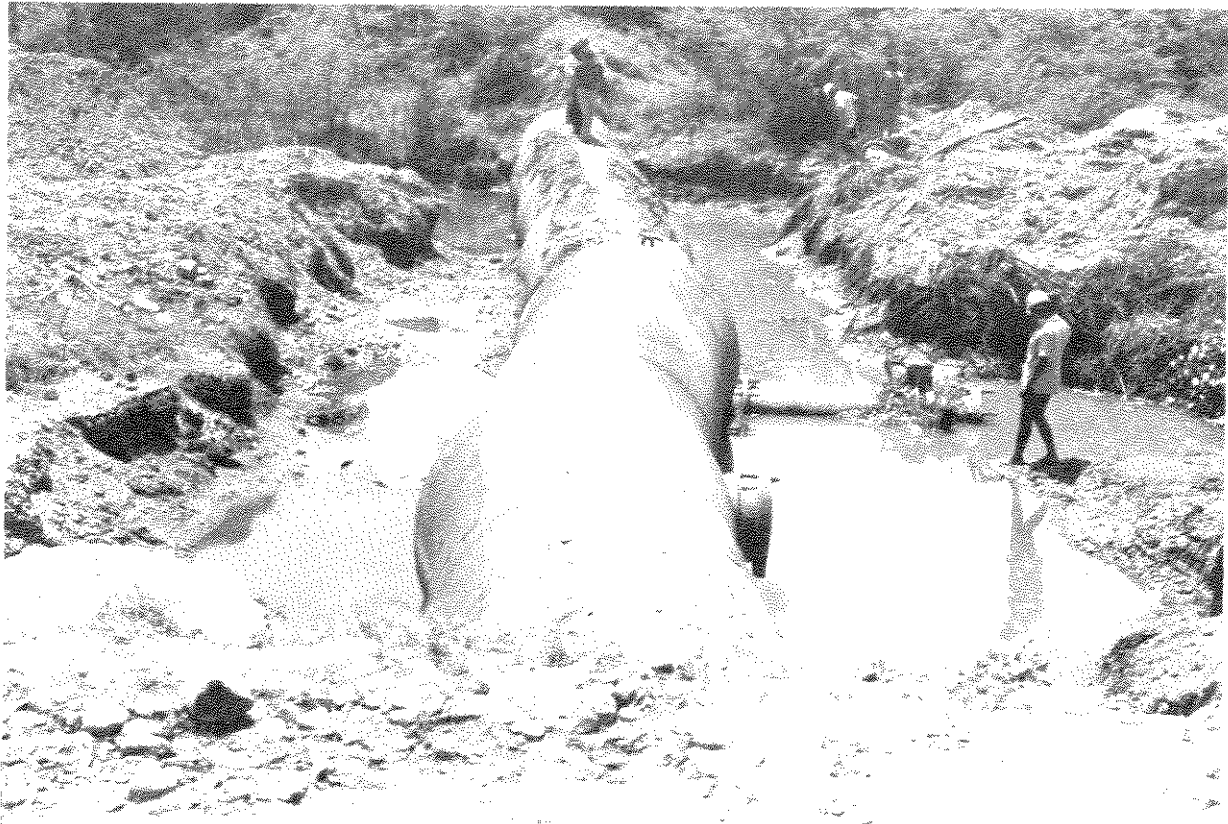

FIGURE 9-3 Damage To A 72"φ Above Ground Pipeline, Epicentral Region, 1985 Michoacan Earthquake

supply pipelines did not transverse the liquefied zones and hence the liquefaction did not result in pipeline damage.

9.2 Analysis of Damage

At first glance it may seem strange that water system damage in the epicentral region was significantly less than in Mexico City which is located about 400 km (240 miles) northeast of the epicenter. A ground motion station at La Villita is close to the September 19, 1985 epicenter. As shown in figure 9-1 La Villita is also reasonably close to Lazaro Cardenas. The peak horizontal ground acceleration recorded during the September 19, 1985 event at La Villita were 125 gals (N-S) and 122 gals (E-W). Referring to Tables 5-I and 5-II, these epicentral accelerations were three to four times larger than those recorded in the Hill Zone of Mexico City but were about the same amplitude as those recorded in the Lake Zone of Mexico City. Note that the two Tlahuac stations recorded peak horizontal ground acceleration of 136 gals (TLHB N-S), 107 gals (TLHB E-W), 118 gals (TLHD N-S) and 115 gals (TLHD E-W). That is, in terms of peak ground acceleration, the decrease in ground motion due to attenuation between the epicentral region and Mexico City was essentially canceled by amplification due to soft soil deposits in the Lake Zones of Mexico City. However, of more importance to buried lifelines are differences in the frequency content and resulting ground velocities and displacements between the epicentral region and Mexico City. The marked difference in frequency contents are shown in figure 9-4 and 9-5 which present horizontal acceleration time histories at La Villita and Tlahuac Bombas. Note that the epicentral record (La Villita) has a much higher frequency content than the Lake Zone Mexico City record (Tlahuac Bombas). Hence although the peak ground accelerations were comparable, the longer period motion in the Lake Zone of Mexico City resulted in significantly higher peak ground velocities and peak ground displacements than in the epicentral region.

The average values for the peak horizontal ground velocity and displacements at La Villita were 13.3 cm/sec and 5.4 cm respectively. As shown in Table 5-II, the corresponding values for the Lake Zone of Mexico City were 42.1 cm/sec and 25.3 cm.

Since pipeline response to seismic wave propagation is related theoretically to peak ground velocity, it is not surprising that the buried water system components in Mexico City were heavily damaged by the 1985 Michoacan earthquake while the system in Lazaro Cardenaes was only slightly damaged.

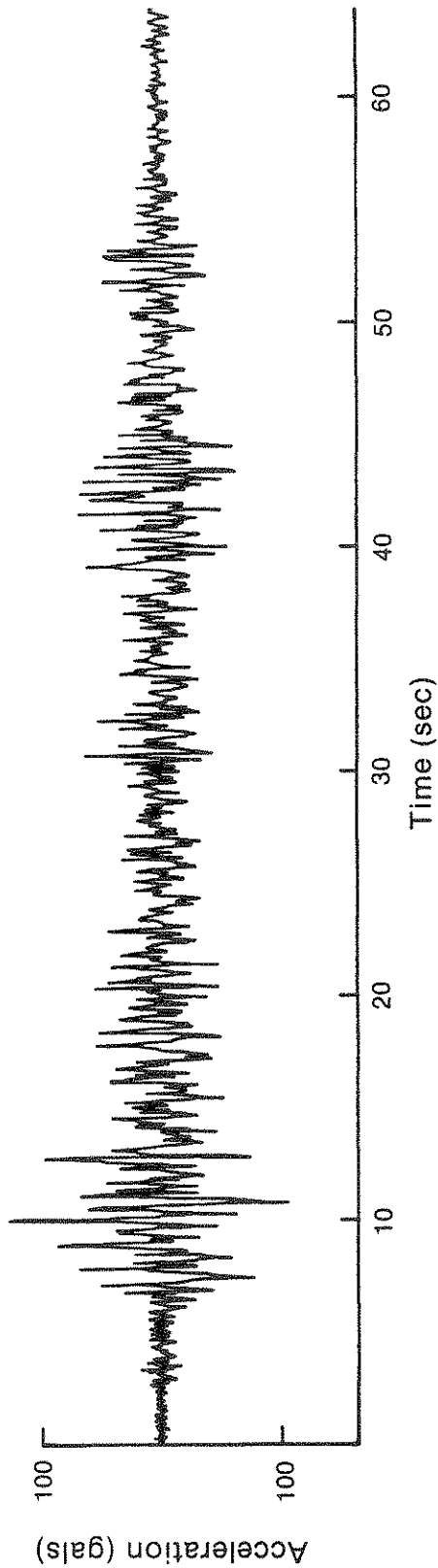

a) La Villita (Epical Region)

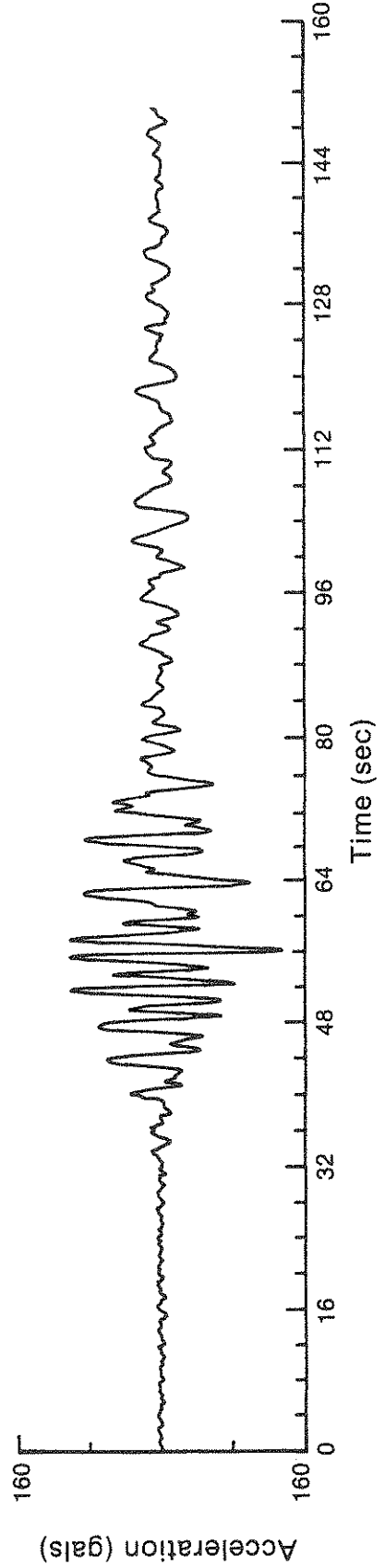

b) Tlahuac Bombas (Mexico City)

FIGURE 9-4 North-South Acceleration Time Histories In Epical Region And Mexico City - 1985 Michoacan Earthquake

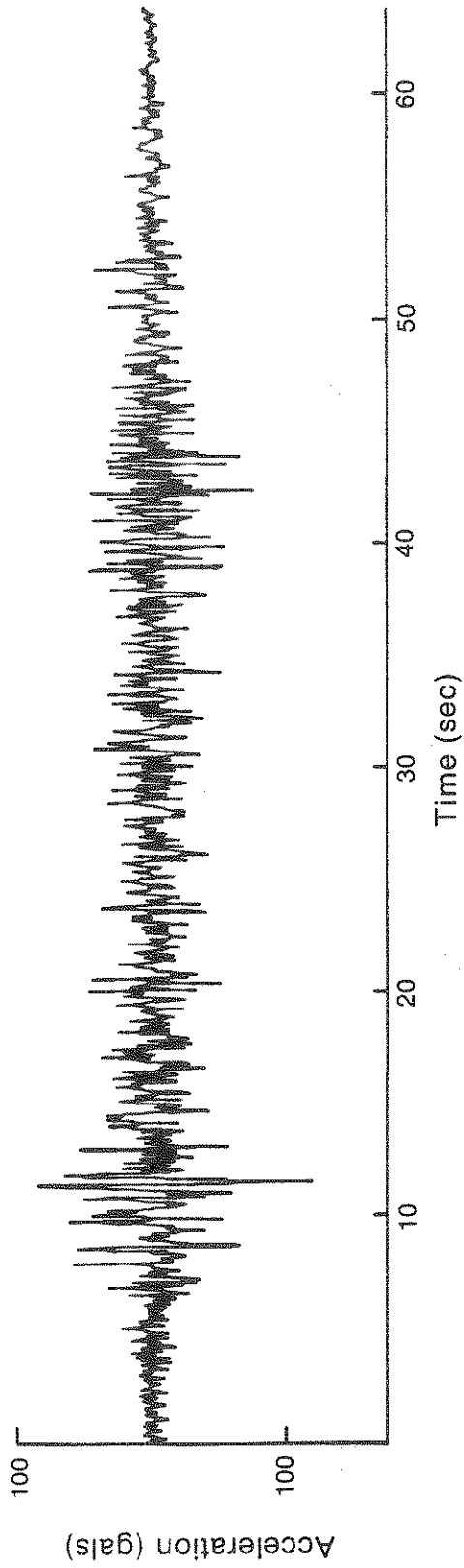

a) La Villita (Epicentral Region)

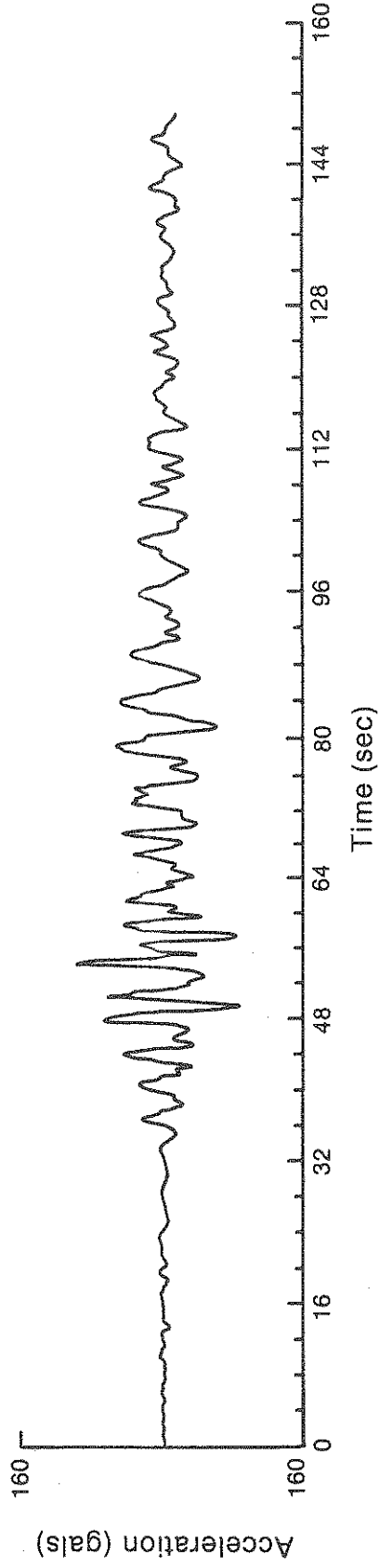

b) Tlahuac Bombas (Mexico City)

FIGURE 9-5 East-West Acceleration Time Histories In Epicentral Region And Mexico City, 1985 Michoacan Earthquake

SECTION 10
SUMMARY AND RECOMMENDATIONS

Information on seismic damage to the water systems of Mexico caused by the September 1985 event was compiled and analyzed in this report. All known sources of information were explored and data was used from those considered reliable.

10.1 Summary

The characteristics of the Michoacan earthquakes and the local soil conditions in Mexico City led to widespread damage to the water systems in the metropolitan area. Approximately one third of the 18 million residents of the metropolitan area were without water after the earthquake. There was no observed soil liquefaction or permanent ground displacement in the Mexico City area. Hence the water service disruption is attributed to seismic wave propagation damage to buried pipelines. Other water system components such as tanks, pumping stations and treatment facilities were not significantly damaged.

Most of the damage occurred in segmented piping which comprise the vast majority of the transmission and distribution network. However, the one continuous steel water pipeline in the system was also damaged. Damage to this Ciudad Nezahualcoyolt pipeline is unusual in that earthquakes in other parts of the world have apparently not resulted in seismic wave propagation damage to modern continuous steel pipelines. The Ciudad Nezahualcoyolt damage appears to be due to fairly high peak ground velocity, very low soil stiffness and the apparent presence of surface waves in this area of the Valley of Mexico.

In the segmented pipeline, the damage typically occurred at joints due to an inability of the joint to accommodate earthquake induced extension, compression and rotation. These leaks/breaks often occurred near T's, elbows, junction boxes or other hard spots. A possible contributing factor is the subsidence which the metropolitan area has experienced over the past decades. The pipeline deformation due to this subsidence reduced somewhat the ability of

the pipelines to accommodate without failure the earthquake induced deformation. However the ground strain due to subsidence is estimated to be at least an order of magnitude lower than the seismic strain produced by the 1985 event.

In the rush to restore the system after the earthquake, information gathered on leaks/breaks was not as detailed as one would like. Nevertheless, the analysis contained herein indicates that the damage was heaviest in the soft soil areas (ie, Lake Zone) and significantly less in the harder soil areas (ie, Transition Zone and Hill Zone). In the affected zones, the leak/break rate for the primary distribution pipelines (20"φ and above) ranged from about 0.2 to 1.5 repairs/km with an average value of about 0.3 repairs/km. Figure 6.25 presents a plot of leak rate versus peak ground velocity.

A buried aqueduct in the southeastern portion of the metropolitan area near Tlahuac suffered significant damage. The damage to this large (72"φ) segmented prestressed concrete line can be attributed to large amplitude and the large local variations in ground motion in this valley between two mountains.

Damage was also extensive in smaller diameter piping. One important observation in relation to the smaller diameter piping is the absence of seismic damage to PVC service connections used in the State of Mexico while there were numerous leaks/breaks in the galvanized iron service connections used in the Federal District.

Although the peak ground acceleration in the epicenter region and in the Lake Zone at Mexico City were comparable, the long period frequency content of the Mexico City records lead to peak ground velocity and displacements which were many times larger than those in the epicentral region. As a result, buried pipeline damage in the epicentral region was light compared to that in Mexico City.

10.2 Recommendations

Reducing the seismic vulnerability of an existing water system is a formidable

task. For almost all such systems, replacing the existing elements with ones which have enhanced seismic resistance would be economically impractical. However, the authors feel that the following recommendations are worthy of consideration.

- 1) All new construction, as well as routine replacements of existing parts of the system, should be made with seismically resistant elements. For buried segmented pipelines, this can be accomplished by using joint details which allows significant axial extension, axial compression and rotation without failure. An alternate approach is to use shorter pipe segment lengths particularly near T's, elbows, valve boxes etc. This would result in more joints per unit length at these critical areas and hence enhanced ability to accommodate seismic deformation without failure.
- 2) Typical repair items should be stockpiled in an open yard or a earthquake resistant building. This would facilitate rapid repair after an earthquake.
- 3) An emergency response plan should be prepared. This would include designation of an emergency headquarters as well as an alternate with system maps, establishing a line of command with alternates, purchase emergency communication devices (ie hand-held radios), etc.
- 4) As part of routine maintenance, shutoff valves should be checked on a regular basis and nonfunctioning valves replaced. This would allow small segments of the system to be isolated after an earthquake, quickly dewatered, and repaired.
- 5) New forms should be developed so that seismic damage to water systems can be properly documented. This would serve two purposes. First of all, properly documented pipeline damage is needed before a water system in the U.S. can be reimbursed from Federal Emergency Funds. Secondly, detailed information on location and specific damage will allow researchers and water system officials to better understand the problem.

SECTION 11
REFERENCES

1. Ayala A.G., "Seismic Design of Buried Pipelines", (in Spanish), Ingenieri Hidraulica en Mexico, Vol. 2, No.1, 1986, pp. 76-80
2. O'Rourke M.J., "Earthquakes and Buried Pipelines, Mexico City 1985 and Beyond", Abatement of Seismic Hazards to Lifelines; Proceedings of a Workshop on Development of an Action Plan. Vol. 1, Papers on Water and Sewer Lifeline, Federal Emergency Management Agency, FEMA 135/July 1987.
3. Suarez, G., 'The Seismic Potential in Mexico: A Historic Perspective', (in Spanish), Proceedings of the National Symposium in Earthquake Engineering, National Society of Earthquake Engineering, Mexico, November 1986.
4. Lee G.M. and Moreno-Mejia S., "The Effects of the 1985 Mexico City Earthquake on Underground Water and Sewer Pipelines", Lifeline Seismic Risk Analysis - Case Studies, Eguchi R.T. (ed). ASCE, 1986, pp 131-137.
5. Marsal R.J., "The Lacustrine Clays of the Valley of Mexico", Report E16, Instituto de Ingenieri, UNAM, Mexico 1975.
6. Marsal R.J., and Mazari M, "The Subsoil of Mexico City," Instituto de Ingenieria, UNAM, Mexico, 1959.
7. Suarez, M., Sanchez-Sesma, F., Bravo, M., and Lerno, J., "Caracteristicas de los Depositos Superficiales del Valle de Mexico" Instituto de Ingenieria, UNAM Mexico, May 1987.
8. Ayala, G et al 'Basic Studies for the Elaboration of Reinforcing and Repairing Plans', (in Spanish), Research Report Proy 6505, Instituto de Ingenieria, UNAM, November 1986.
9. Bresko D., "Seismic Risk Analysis of a Water System", Research Report NSF-RANH, ENV-75-20977, Department of Civil Engineering Carnegie-Mellon University - GAI Consultants Inc., Pittsburgh, PA June 1980.

10. Katayama T., et. al., "Earthquake Damage to Water and Gas Distribution Systems", Proc. U.S. National Conference on Earthquake Engineering, EERI, Ann Arbor, Michigan, 1975, pp 396-405.
11. O'Rourke, M., and El Hmadi, K., "Analysis of Continuous Buried Pipelines For Seismic Wave Effects" accepted Inter. J. Earthquake Engineering and Structural Dynamics.
12. O'Rourke, M., Castro, G., and Hossain, I., "Horizontal Soil Strain Due to Seismic Waves", J. Geotechnical Engineering, ASCE, Vol 110, No.9, September 1984, pp. 1173-87.
13. Schwab, F., and Knopff, L., "Fast Surface Wave and Free Mode Computations" in Seismology; Surface Waves and Earth Oscillations, ed Bolt, B., Methods in Computational Physics, Vol 11, Academic Press, N.Y. 1977 pp. 87-180.
14. Schilling, C, "Buckling Strength of Circular Tubes" Journal of Structural Div., ASCE, Vol 91, No. ST5, Oct. 1965, pp 325-348.
15. Harris, L., Sver, H., Skene, W., and Benjamin, R., "The Stability of Thin-Walled Unstiffened Circular Cylinders Under Axial Compression Including the Effects of Internal Pressure" Journal of Aeronautical Sciences, Vol 24, No. 8, Aug. 1957, pp. 587-596.
16. Newmark, N., "A Study of Vertical and Horizontal Earthquake Spectra", Directorate of Licensing, U.S. Atomic Energy Commission, Washington, D.C., 1973.
17. Kausel, E., "Mexico City's 1985 Earthquake: The Influence of Local Soil Conditions on Damage," Research in progress, Department of Civil Engineering, Massachusetts Institute of Technology, Cambridge, MA, 1988.

**NATIONAL CENTER FOR EARTHQUAKE ENGINEERING RESEARCH
LIST OF PUBLISHED TECHNICAL REPORTS**

The National Center for Earthquake Engineering Research (NCEER) publishes technical reports on a variety of subjects related to earthquake engineering written by authors funded through NCEER. These reports are available from both NCEER's Publications Department and the National Technical Information Service (NTIS). Requests for reports should be directed to the Publications Department, National Center for Earthquake Engineering Research, State University of New York at Buffalo, Red Jacket Quadrangle, Buffalo, New York 14261. Reports can also be requested through NTIS, 5285 Port Royal Road, Springfield, Virginia 22161. NTIS accession numbers are shown in parenthesis, if available.

- NCEER-87-0001 "First-Year Program in Research, Education and Technology Transfer," 3/5/87, (PB88-134275/AS).
- NCEER-87-0002 "Experimental Evaluation of Instantaneous Optimal Algorithms for Structural Control," by R.C. Lin, T.T. Soong and A.M. Reinhorn, 4/20/87, (PB88-134341/AS).
- NCEER-87-0003 "Experimentation Using the Earthquake Simulation Facilities at University at Buffalo," by A.M. Reinhorn and R.L. Ketter, to be published.
- NCEER-87-0004 "The System Characteristics and Performance of a Shaking Table," by J.S. Hwang, K.C. Chang and G.C. Lee, 6/1/87, (PB88-134259/AS).
- NCEER-87-0005 "A Finite Element Formulation for Nonlinear Viscoplastic Material Using a Q Model," by O. Gyebi and G. Dasgupta, 11/2/87, (PB88-213764/AS).
- NCEER-87-0006 "Symbolic Manipulation Program (SMP) - Algebraic Codes for Two and Three Dimensional Finite Element Formulations," by X. Lee and G. Dasgupta, 11/9/87, (PB88-219522/AS).
- NCEER-87-0007 "Instantaneous Optimal Control Laws for Tall Buildings Under Seismic Excitations," by J.N. Yang, A. Akbarpour and P. Ghaemmaghami, 6/10/87, (PB88-134333/AS).
- NCEER-87-0008 "IDARC: Inelastic Damage Analysis of Reinforced Concrete Frame - Shear-Wall Structures," by Y.J. Park, A.M. Reinhorn and S.K. Kunnath, 7/20/87, (PB88-134325/AS).
- NCEER-87-0009 "Liquefaction Potential for New York State: A Preliminary Report on Sites in Manhattan and Buffalo," by M. Budhu, V. Vijayakumar, R.F. Giese and L. Baumgras, 8/31/87, (PB88-163704/AS). This report is available only through NTIS (see address given above).
- NCEER-87-0010 "Vertical and Torsional Vibration of Foundations in Inhomogeneous Media," by A.S. Veletsos and K.W. Dotson, 6/1/87, (PB88-134291/AS).
- NCEER-87-0011 "Seismic Probabilistic Risk Assessment and Seismic Margins Studies for Nuclear Power Plants," by Howard H.M. Hwang, 6/15/87, (PB88-134267/AS). This report is available only through NTIS (see address given above).
- NCEER-87-0012 "Parametric Studies of Frequency Response of Secondary Systems Under Ground-Acceleration Excitations," by Y. Yong and Y.K. Lin, 6/10/87, (PB88-134309/AS).
- NCEER-87-0013 "Frequency Response of Secondary Systems Under Seismic Excitation," by J.A. HoLung, J. Cai and Y.K. Lin, 7/31/87, (PB88-134317/AS).
- NCEER-87-0014 "Modelling Earthquake Ground Motions in Seismically Active Regions Using Parametric Time Series Methods," by G.W. Ellis and A.S. Cakmak, 8/25/87, (PB88-134283/AS).
- NCEER-87-0015 "Detection and Assessment of Seismic Structural Damage," by E. DiPasquale and A.S. Cakmak, 8/25/87, (PB88-163712/AS).
- NCEER-87-0016 "Pipeline Experiment at Parkfield, California," by J. Isenberg and E. Richardson, 9/15/87, (PB88-163720/AS).

- NCEER-87-0017 "Digital Simulation of Seismic Ground Motion," by M. Shinozuka, G. Deodatis and T. Harada, 8/31/87, (PB88-155197/AS). This report is available only through NTIS (see address given above).
- NCEER-87-0018 "Practical Considerations for Structural Control: System Uncertainty, System Time Delay and Truncation of Small Control Forces," J.N. Yang and A. Akbarpour, 8/10/87, (PB88-163738/AS).
- NCEER-87-0019 "Modal Analysis of Nonclassically Damped Structural Systems Using Canonical Transformation," by J.N. Yang, S. Sarkani and F.X. Long, 9/27/87, (PB88-187851/AS).
- NCEER-87-0020 "A Nonstationary Solution in Random Vibration Theory," by J.R. Red-Horse and P.D. Spanos, 11/3/87, (PB88-163746/AS).
- NCEER-87-0021 "Horizontal Impedances for Radially Inhomogeneous Viscoelastic Soil Layers," by A.S. Veletsos and K.W. Dotson, 10/15/87, (PB88-150859/AS).
- NCEER-87-0022 "Seismic Damage Assessment of Reinforced Concrete Members," by Y.S. Chung, C. Meyer and M. Shinozuka, 10/9/87, (PB88-150867/AS). This report is available only through NTIS (see address given above).
- NCEER-87-0023 "Active Structural Control in Civil Engineering," by T.T. Soong, 11/11/87, (PB88-187778/AS).
- NCEER-87-0024 "Vertical and Torsional Impedances for Radially Inhomogeneous Viscoelastic Soil Layers," by K.W. Dotson and A.S. Veletsos, 12/87, (PB88-187786/AS).
- NCEER-87-0025 "Proceedings from the Symposium on Seismic Hazards, Ground Motions, Soil-Liquefaction and Engineering Practice in Eastern North America," October 20-22, 1987, edited by K.H. Jacob, 12/87, (PB88-188115/AS).
- NCEER-87-0026 "Report on the Whittier-Narrows, California, Earthquake of October 1, 1987," by J. Pantelic and A. Reinhorn, 11/87, (PB88-187752/AS). This report is available only through NTIS (see address given above).
- NCEER-87-0027 "Design of a Modular Program for Transient Nonlinear Analysis of Large 3-D Building Structures," by S. Srivastav and J.F. Abel, 12/30/87, (PB88-187950/AS).
- NCEER-87-0028 "Second-Year Program in Research, Education and Technology Transfer," 3/8/88, (PB88-219480/AS).
- NCEER-88-0001 "Workshop on Seismic Computer Analysis and Design of Buildings With Interactive Graphics," by W. McGuire, J.F. Abel and C.H. Conley, 1/18/88, (PB88-187760/AS).
- NCEER-88-0002 "Optimal Control of Nonlinear Flexible Structures," by J.N. Yang, F.X. Long and D. Wong, 1/22/88, (PB88-213772/AS).
- NCEER-88-0003 "Substructuring Techniques in the Time Domain for Primary-Secondary Structural Systems," by G.D. Manolis and G. Juhn, 2/10/88, (PB88-213780/AS).
- NCEER-88-0004 "Iterative Seismic Analysis of Primary-Secondary Systems," by A. Singhal, L.D. Lutes and P.D. Spanos, 2/23/88, (PB88-213798/AS).
- NCEER-88-0005 "Stochastic Finite Element Expansion for Random Media," by P.D. Spanos and R. Ghanem, 3/14/88, (PB88-213806/AS).
- NCEER-88-0006 "Combining Structural Optimization and Structural Control," by F.Y. Cheng and C.P. Pantelides, 1/10/88, (PB88-213814/AS).
- NCEER-88-0007 "Seismic Performance Assessment of Code-Designed Structures," by H.H.-M. Hwang, J.-W. Jaw and H.-J. Shau, 3/20/88, (PB88-219423/AS).

- NCEER-88-0008 "Reliability Analysis of Code-Designed Structures Under Natural Hazards," by H.H-M. Hwang, H. Ushiba and M. Shinozuka, 2/29/88, (PB88-229471/AS).
- NCEER-88-0009 "Seismic Fragility Analysis of Shear Wall Structures," by J-W Jaw and H.H-M. Hwang, 4/30/88, (PB89-102867/AS).
- NCEER-88-0010 "Base Isolation of a Multi-Story Building Under a Harmonic Ground Motion - A Comparison of Performances of Various Systems," by F-G Fan, G. Ahmadi and I.G. Tadjbakhsh, 5/18/88, (PB89-122238/AS).
- NCEER-88-0011 "Seismic Floor Response Spectra for a Combined System by Green's Functions," by F.M. Lavelle, L.A. Bergman and P.D. Spanos, 5/1/88, (PB89-102875/AS).
- NCEER-88-0012 "A New Solution Technique for Randomly Excited Hysteretic Structures," by G.Q. Cai and Y.K. Lin, 5/16/88, (PB89-102883/AS).
- NCEER-88-0013 "A Study of Radiation Damping and Soil-Structure Interaction Effects in the Centrifuge," by K. Weissman, supervised by J.H. Prevost, 5/24/88, (PB89-144703/AS).
- NCEER-88-0014 "Parameter Identification and Implementation of a Kinematic Plasticity Model for Frictional Soils," by J.H. Prevost and D.V. Griffiths, to be published.
- NCEER-88-0015 "Two- and Three- Dimensional Dynamic Finite Element Analyses of the Long Valley Dam," by D.V. Griffiths and J.H. Prevost, 6/17/88, (PB89-144711/AS).
- NCEER-88-0016 "Damage Assessment of Reinforced Concrete Structures in Eastern United States," by A.M. Reinhorn, M.J. Seidel, S.K. Kunnath and Y.J. Park, 6/15/88, (PB89-122220/AS).
- NCEER-88-0017 "Dynamic Compliance of Vertically Loaded Strip Foundations in Multilayered Viscoelastic Soils," by S. Ahmad and A.S.M. Israil, 6/17/88, (PB89-102891/AS).
- NCEER-88-0018 "An Experimental Study of Seismic Structural Response With Added Viscoelastic Dampers," by R.C. Lin, Z. Liang, T.T. Soong and R.H. Zhang, 6/30/88, (PB89-122212/AS).
- NCEER-88-0019 "Experimental Investigation of Primary - Secondary System Interaction," by G.D. Manolis, G. Juhn and A.M. Reinhorn, 5/27/88, (PB89-122204/AS).
- NCEER-88-0020 "A Response Spectrum Approach For Analysis of Nonclassically Damped Structures," by J.N. Yang, S. Sarkani and F.X. Long, 4/22/88, (PB89-102909/AS).
- NCEER-88-0021 "Seismic Interaction of Structures and Soils: Stochastic Approach," by A.S. Veletsos and A.M. Prasad, 7/21/88, (PB89-122196/AS).
- NCEER-88-0022 "Identification of the Serviceability Limit State and Detection of Seismic Structural Damage," by E. DiPasquale and A.S. Cakmak, 6/15/88, (PB89-122188/AS).
- NCEER-88-0023 "Multi-Hazard Risk Analysis: Case of a Simple Offshore Structure," by B.K. Bhartia and E.H. Vanmarcke, 7/21/88, (PB89-145213/AS).
- NCEER-88-0024 "Automated Seismic Design of Reinforced Concrete Buildings," by Y.S. Chung, C. Meyer and M. Shinozuka, 7/5/88, (PB89-122170/AS).
- NCEER-88-0025 "Experimental Study of Active Control of MDOF Structures Under Seismic Excitations," by L.L. Chung, R.C. Lin, T.T. Soong and A.M. Reinhorn, 7/10/88, (PB89-122600/AS).
- NCEER-88-0026 "Earthquake Simulation Tests of a Low-Rise Metal Structure," by J.S. Hwang, K.C. Chang, G.C. Lee and R.L. Ketter, 8/1/88, (PB89-102917/AS).
- NCEER-88-0027 "Systems Study of Urban Response and Reconstruction Due to Catastrophic Earthquakes," by F. Kozin and H.K. Zhou, 9/22/88, to be published.

- NCEER-88-0028 "Seismic Fragility Analysis of Plane Frame Structures," by H.H.-M. Hwang and Y.K. Low, 7/31/88, (PB89-131445/AS).
- NCEER-88-0029 "Response Analysis of Stochastic Structures," by A. Kardara, C. Bucher and M. Shinozuka, 9/22/88.
- NCEER-88-0030 "Nonnormal Accelerations Due to Yielding in a Primary Structure," by D.C.K. Chen and L.D. Lutes, 9/19/88, (PB89-131437/AS).
- NCEER-88-0031 "Design Approaches for Soil-Structure Interaction," by A.S. Veletsos, A.M. Prasad and Y. Tang, 12/30/88.
- NCEER-88-0032 "A Re-evaluation of Design Spectra for Seismic Damage Control," by C.J. Turkstra and A.G. Tallin, 11/7/88, (PB89-145221/AS).
- NCEER-88-0033 "The Behavior and Design of Noncontact Lap Splices Subjected to Repeated Inelastic Tensile Loading," by V.E. Sagan, P. Gergely and R.N. White, 12/8/88.
- NCEER-88-0034 "Seismic Response of Pile Foundations," by S.M. Mamoon, P.K. Banerjee and S. Ahmad, 11/1/88, (PB89-145239/AS).
- NCEER-88-0035 "Modeling of R/C Building Structures With Flexible Floor Diaphragms (IDARC2)," by A.M. Reinhorn, S.K. Kunnath and N. Panahshahi, 9/7/88.
- NCEER-88-0036 "Solution of the Dam-Reservoir Interaction Problem Using a Combination of FEM, BEM with Particular Integrals, Modal Analysis, and Substructuring," by C-S. Tsai, G.C. Lee and R.L. Ketter, 12/31/88.
- NCEER-88-0037 "Optimal Placement of Actuators for Structural Control," by F.Y. Cheng and C.P. Pantelides, 8/15/88.
- NCEER-88-0038 "Teflon Bearings in Aseismic Base Isolation: Experimental Studies and Mathematical Modeling," by A. Mokka, M.C. Constantinou and A.M. Reinhorn, 12/5/88.
- NCEER-88-0039 "Seismic Behavior of Flat Slab High-Rise Buildings in the New York City Area," by P. Weidlinger and M. Ettouney, 10/15/88, to be published.
- NCEER-88-0040 "Evaluation of the Earthquake Resistance of Existing Buildings in New York City," by P. Weidlinger and M. Ettouney, 10/15/88, to be published.
- NCEER-88-0041 "Small-Scale Modeling Techniques for Reinforced Concrete Structures Subjected to Seismic Loads," by W. Kim, A. El-Attar and R.N. White, 11/22/88.
- NCEER-88-0042 "Modeling Strong Ground Motion from Multiple Event Earthquakes," by G.W. Ellis and A.S. Cakmak, 10/15/88.
- NCEER-88-0043 "Nonstationary Models of Seismic Ground Acceleration," by M. Grigoriu, S.E. Ruiz and E. Rosenblueth, 7/15/88.
- NCEER-88-0044 "SARCF User's Guide: Seismic Analysis of Reinforced Concrete Frames," by Y.S. Chung, C. Meyer and M. Shinozuka, 11/9/88.
- NCEER-88-0045 "First Expert Panel Meeting on Disaster Research and Planning," edited by J. Pantelic and J. Stoyke, 9/15/88.
- NCEER-88-0046 "Preliminary Studies of the Effect of Degrading Infill Walls on the Nonlinear Seismic Response of Steel Frames," by C.Z. Chrysostomou, P. Gergely and J.F. Abel, 12/19/88.
- NCEER-88-0047 "Reinforced Concrete Frame Component Testing Facility - Design, Construction, Instrumentation and Operation," by S.P. Pessiki, C. Conley, T. Bond, P. Gergely and R.N. White, 12/16/88.

- NCEER-89-0001 "Effects of Protective Cushion and Soil Compliancy on the Response of Equipment Within a Seismically Excited Building," by J.A. HoLung, 2/16/89.
- NCEER-89-0002 "Statistical Evaluation of Response Modification Factors for Reinforced Concrete Structures," by H.H-M. Hwang and J-W. Jaw, 2/17/89.
- NCEER-89-0003 "Hysteretic Columns Under Random Excitation," by G-Q. Cai and Y.K. Lin, 1/9/89.
- NCEER-89-0004 "Experimental Study of 'Elephant Foot Bulge' Instability of Thin-Walled Metal Tanks," by Z-H. Jia and R.L. Ketter, 2/22/89, to be published.
- NCEER-89-0005 "Experiment on Performance of Buried Pipelines Across San Andreas Fault," by J. Isenberg, E. Richardson and T.D. O'Rourke, 3/10/89, to be published.
- NCEER-89-0006 "A Knowledge-Based Approach to Structural Design of Earthquake-Resistant Buildings," by M. Subramani, J.F. Abel, P. Gergely and C.H. Conley, 1/15/89, to be published.
- NCEER-89-0007 "Liquefaction Hazards and Their Effects on Buried Pipelines," by T.D. O'Rourke and P.A. Lane, 2/1/89, to be published.
- NCEER-89-0008 "Fundamentals of System Identification in Structural Dynamics," by H. Imai, C-B. Yun, O. Maruyama and M. Shinozuka, 1/26/89.
- NCEER-89-0009 "Effects of the 1985 Michoacan Earthquake on Water Systems and Other Buried Lifelines in Mexico," by A.G. Ayala and M.J. O'Rourke, 3/8/89.

