

Resilience-Based Design of Natural Gas Distribution Networks

G. P. Cimellaro, Ph.D., A.M.ASCE¹; O. Villa²; and M. Bruneau, A.M.ASCE³

Abstract: The concept of disaster resilience has received considerable attention in recent years and is increasingly used as an approach for understanding the dynamic response to natural disasters. In this paper, a new performance index measuring the functionality of a gas distribution network has been proposed, which includes the restoration phase to evaluate the resilience index of the entire network. The index can also be used for any type of natural or artificial hazard, which might lead to the disruption of the system. The gas distribution network of the municipalities of Introdacqua and Sulmona, two small towns in the center of Italy that were affected by the 2009 earthquake, has been used as a case study. The pipeline network covers an area of 136 km², with three metering pressure reduction (M/R) stations and 16 regulation groups. Different analyses simulating different breakage scenario events due to an earthquake have been considered. The numerical results showed that the functionality of the medium-pressure gas distribution network is crucial for ensuring an acceptable delivery service during the postearthquake response. Furthermore, the best retrofit strategy to improve the resilience index of the entire network should include emergency shutoff valves along the steel pipes. **DOI: 10.1061/(ASCE)IS.1943-555X.0000204.** © 2014 American Society of Civil Engineers.

Author keywords: Resilience; Disaster resilience; Vulnerability; Gas networks; Damage assessment; Lifelines; Serviceability; Natural gas; Distributed systems; Resilience-based design.

Introduction

The reliability assessment of infrastructure systems providing power, natural gas, and potable water is an integral part of societal preparedness to unforeseen hazards (e.g., earthquakes and fire). Earthquake safety of lifeline systems (e.g., gas networks, power networks, water distribution systems, and road transportation systems) has attracted great attention in recent years. In fact, a significant amount of damage was observed especially in the gas distribution networks during recent earthquakes such as the 1995 Kobe, 1999 Kocaeli (Scawthorn and Johnson 2000), 1999 Chi-Chi (Chen et al. 2002), and 2011 Great East Japan Earthquake. These earthquakes occurred mainly close to urban areas and caused significant damage to buried pipelines because of their dimensions and because of weaknesses in the system such as aging and corrosion of rigid joints.

In the European Union, more than 20% of the total energy consumption comes from natural gas (Montiel et al. 1996), which is currently one of the most important sources of energy. According to the national data in Italy from 1971 to 2006, the primary forms of energy include fossil fuels (i.e., coal, natural gas, and petroleum), which are responsible for most of the national electric energy supply, with most of the remainder being hydroelectric energy and a smaller percentage being renewable sources (e.g., wind and solar).

Then the gas distribution network has a significant impact on the Italian national economy; however, because of earthquakes and other extreme events such as landslides, it is often exposed to significant economic, social, and physical disruptions. One of the major hazards after earthquakes for gas pipelines is fire because an escape of gas, either within a building or on a network, can result in a fire or explosion. The risk of fire or explosion due to gas leakages is significantly higher inside a building than outside; however, the hazard arising from gas leakages in a distribution system may be more severe than in the transmission pipelines; therefore, this paper focuses on gas leakages in an urban gas distribution network. In fact, disruptions of the gas distribution network can induce significant consequences on the population and the economy of the community. The literature related to the seismic performance of the gas distribution networks has focused mainly on the seismic vulnerability of gas pipelines when subjected to permanent ground deformations (PGDs) and liquefaction (Jeon and O'Rourke 2005; Choo et al. 2007). More attention on the overall gas network performance has been provided by Shinozuka et al. (1999), who focused on loss estimation methodologies for lifelines, considering loss of connectivity between substations, failure of substations, and imbalance of the power system under a scenario earthquake in the Memphis, Tennessee, area. Recently, Adachi and Ellingwood (2008) focused on infrastructure system interactions due to earthquakes using fault-tree analysis and a shortest-path algorithm.

When considering risk assessments methods for natural gas distribution networks, several approaches are available in literature, which can be grouped in qualitative and quantitative methods (Han and Weng 2011). Qualitative methods use indexes, which are based on pipeline length, flow rate, population density, and external interferences. Several approaches are available for qualitative methods such as analytical hierarchy process (AHP), event-tree analysis (ETA), data envelopment analysis (DEA), and fuzzy logic (FL) method (Markowski and Mannan 2009; Yuhua and Datao 2005). The limit of these methods is that they can identify the causes of the accidents, but are not able to identify the risk.

¹Assistant Professor, Dept. of Structural, Building and Geotechnical Engineering (DISEG), Politecnico di Torino, 10129 Turin, Italy (corresponding author). E-mail: gianpaolo.cimellaro@polito.it

²Research Engineer, ITALGAS.SPA, Largo Regio Parco 9, 10153 Turin, Italy. E-mail: Omar.Villa@mail.italgas.it

³Professor, Dept. of Civil, Structural and Environmental Engineering, Univ. at Buffalo (SUNY), State Univ. of New York, 130 Ketter Hall, Buffalo, NY 14260. E-mail: bruneau@buffalo.edu

Note. This manuscript was submitted on September 4, 2012; approved on November 26, 2013; published online on March 7, 2014. Discussion period open until August 7, 2014; separate discussions must be submitted for individual papers. This paper is part of the *Journal of Infrastructure Systems*, © ASCE, ISSN 1076-0342/05014005(14)/\$25.00.

Quantitative methods are based on probability assessment (Cimellaro and Reinhorn 2011), consequences analysis, and risk evaluation of gas distribution networks. Belonging to this group is the recent method proposed by Poljansek et al. (2012), which analyzed the seismic vulnerability of the gas and electric network from the topological point of view. However, the limit of these methods is that they fail analyzing the consequences of various accidents, which can cause different harms to people (Jo and Crowl 2008).

The studies summarized previously consider the performance measures of the gas distribution network and other lifelines in general; only a few studies on seismic risk analysis of gas distribution networks take into account all the aspects of the component of risk (hazard, vulnerability, and loss), but none of them take into account the restoration process during the analysis. Therefore, further research is required to evaluate the economic and social consequences caused by the reduced functionality of a damaged gas distribution network and its consequences (Cimellaro 2013).

In sum, this paper introduces a performance assessment methodology for gas distribution networks including the restoration process right after an extreme event such an earthquake.

This paper is organized as follows. First, the paper outlines the motivations of the research and provides the state of art related to the seismic performance of the gas network.

Second, the performance index is presented along with the required methodological steps for the natural gas distribution network. Then, a description of the Italian natural gas supply system both at the national and local level is provided, which includes the analysis of the restoration process. Third, the model's assumptions in describing the network and the failure mode are described. Fourth, the method is applied to the gas distribution network of the municipalities of Introdacqua and Sulmona, two small towns in the center of Italy that were affected by the 2009 earthquake, which have been used as case study to show the implementation issues of the proposed methodology. Different breakage scenarios due to an earthquake have been selected considering the deaggregated seismic hazard maps and the seismic damage assessment of the distributing elements. Then the paper analyzes the results of the numerical analyses and provides retrofit recommendations in practice. Finally, the paper presents major conclusions concerning the proposed performance assessment methodology of the gas distribution network.

Performance Assessment Procedure of Natural Gas Distribution Network

There is a large debate in literature on how resilience is defined. An extensive description of the state of the art in the definition of resilience can be found in Cimellaro et al. (2009). After analyzing the literature carefully, the definition provided by Bruneau et al. (2003), which has been clarified and extended in Cimellaro et al. (2010a, b), has been adopted.

Performance of a system can be measured through a unique decision variable defined as resilience (R), which combines other dimensions (e.g., economic losses, casualties, recovery time) that are usually employed to judge the performance of a network. In other words, resilience is an index measuring the capacity to sustain a level of functionality or performance for a given infrastructure or community over a given period range. It can be defined graphically as the normalized shaded area underneath the functionality of a system $Q(t)$ given in Fig. 1. Analytically, resilience is defined as (Cimellaro et al. 2010b)

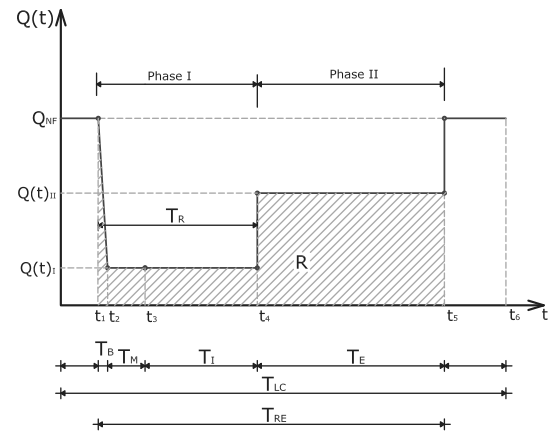

Fig. 1. Functionality of natural gas network after disruption

$$R = \int_{t_1}^{t_6} \frac{Q(t)}{T_{LC}} dt \quad (1)$$

where $Q(t)$ = nonstationary stochastic process and each ensemble is a piecewise continuous function as the one shown in Fig. 1; T_{LC} = control period range that is usually decided by owners or communities (usually is the life cycle or life span of the system, or it can be a shorter period depending on the problem at hand) (Cimellaro et al. 2010a); t_1 = time instant when resilience starts to be evaluated; $t_6 = t_1 + T_{LC}$ is the time instant when resilience evaluation ends. The control period range T_{LC} has been divided in two phases as shown in Fig. 1. Phase I corresponds to the period range necessary to repair the distribution network and go back to partial service after the extreme event. During this phase, there is no gas network in service because the valves are closed, so pipes are empty. Phase II corresponds to the period range right after the first emergency intervention on the gas network, during which the network is partially in service, before reaching full restoration. Different period ranges can be distinguished inside the two phases: T_B = network balancing period range; T_M = operating period range, which should be less than 1 h according to the ITALGAS regulations; T_I = repair period range to bring the network to partial service in Phase II; T_E = transition period during which the network is partially in service, which corresponds to Phase II; $T_{RE} = (T_B + T_M + T_I + T_E)$ = recovery period range.

The gas flow in the network after disruption is shown in Fig. 2. After the pipeline breaks, the flow in the network increases to the

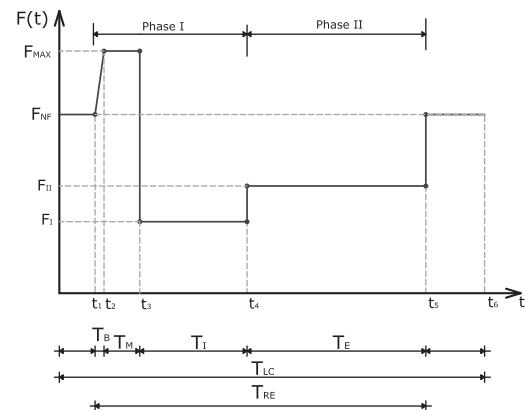

Fig. 2. Flow rate inside the pipelines after disruption

maximum system capability F_{MAX} (Phase I) during the balancing period T_B . Then, after repairing, the network goes back to partial service and the flow reduces to lower values with respect to the flow F_{NF} in normal operating conditions. The evaluation of resilience using Eq. (1) necessitates the definition of the serviceability or functionality of the analyzed system. Communities depend heavily on the availability of distributed civil infrastructure systems, such as the gas distribution networks. During the emergency, the serviceability of such systems can be measured by the ratio of the satisfied customer demand to the total customer demand within the area served. However, serviceability can be directly correlated to the gas flow and the length of operating pipes. These are quantities that can be determined more easily during numerical analysis using commercial software available in the market. Therefore, based on these practical considerations, a new functionality index $Q(t)$ of the gas distribution network is proposed as a combination of the normalized gas flow rate and the total length of the network in service before and after the event. Therefore, $Q(t)$ of the gas network is given by the following expression:

$$Q(t) = \left[w_1 \cdot \frac{F(t)}{F_{NF}} + w_2 \cdot \frac{L(t)}{L_{NF}} \right] \cdot 100;$$

$$\text{where} \begin{cases} \text{if } t_3 \leq t \leq t_4 & w_1 = 1; w_2 = 0 \\ \text{if } t_4 < t \leq t_5 & \forall w_1 \in [0, 1]; w_2 = 1 - w_1 \end{cases} \quad (2)$$

where F_{NF} = gas flow in normal operating conditions; L_{NF} = length in kilometers of the gas network working in normal operating conditions; $F(t)$ = gas flow right after the extreme event and after the valve closure by the operator ($t \geq t_3$); L = length of gas network in partial service after the extreme event (e.g., earthquake); and w_1, w_2 = weight factors. The weights inside Eq. (2) describe the significance of the two combined indexes, which take into account both pipeline length and flow rate and they can be determined using the reliability engineering theory and the Gray correlation theory. Therefore, the evaluation of weights is based on the real data of gas pipeline network such as operation information, environment information, and statistical analysis of historical accident data (Han and Weng 2011). However, when no information is provided, both values can be assumed equal to 0.5, such as in the case study described subsequently. In fact, it has been proven that there is not much difference in the final results of the resilience index if more complex methods to evaluate the weights are provided such as the one proposed by Cimellaro et al. (2013).

Restoration Model

The restoration model and the recovery time T_{RE} , which corresponds to the time necessary to restore the gas distribution network to the initial conditions, are essential components for the resilience quantification of the gas network. In particular, T_{RE} is a parameter characterized by high uncertainties due to the difficulty of evaluating and distinguishing between the shutoff time and the repairing time. The restoration phase of the components of the gas distribution network has been evaluated using the technical reports made by ITALGAS (the distribution network operator in the region) that describe the repair and replacement activities following the earthquake. Unfortunately, the technical reports describing the repair activities right after the earthquake in the month of April 2009 are not available because assistance and emergency support interventions were the main operations undertaken during the first month, with a limited activity of repair and restoration of the gas network. However, on the reports of the following months, it could be observed that right after the main shock and during the first phase of the

emergency, the gas network was shut down to avoid explosions, gas leaks, and fires and to allow emergency vehicles and search-and-rescue teams to act in the safest way possible. To ensure this priority, the entire network in the affected area was shut off via the closure of the three operating metering pressure reduction (M/R) stations in less than 2 h. In the days following the event, all the gas valves external to each residential building were closed as well. The recovery phase following the earthquake started gradually opening first the gas flow in the medium pressure network, then in the low-pressure (LP) network, and finally in the external end-user valves of each residential building that were previously closed. The restoration process, which lasted a few days, was the only option for the emergency management authorities because emergency shutoff valves were not inserted in the network. The presence of these valves would have avoided the shutdown of the entire network and limited the damage effects as shown in the numerical example in this paper.

In detail, the service reactivation was managed in the following four steps: (1) seal verification; (2) nitrogen check; (3) repair of damaged pipes and/or valves; and (4) reopening. In the seal verification phase, the detection of broken pipes and/or the possible joint slip off was made, acting in the first instance, from node to node, and further segmenting the network when necessary. The adopted strategy ensured the restoration of more than 90% of the gas network in 3 months after the earthquake. Using the same restoration strategy described previously, which is based on real information available from the most recent earthquake in the region, it has been assumed a recovery period T_{RE} of 4 months for the scenario events considered in the analyses to ensure the restoration of full functionality. During the 2009 earthquake in the region, no damage to the gas facilities was detected; therefore, the adopted restoration time that is a function of the failure mode is valid only for pipeline failures due to permanent ground deformations, which is the one that was observed during the 2009 earthquake. Other countries like Japan have developed advanced disaster countermeasures; therefore, the recovery time is shorter as in the case of the 2011 Tohoku earthquake in Japan where the eight Japanese municipalities were able to go back to full functionality in less than a month. The reason for this fast recovery is justified from the analysis of the Tokyo gas distribution network. Approximately 4,000 seismographs are installed in different locations throughout the supply area so that local gas supply for each district is shut off automatically in the event of a major earthquake. Segmentation of the gas network is carried out at two levels: one for medium-pressure (MP) lines and another for LP lines (Fig. 3). Emergency shutoff of gas networks can be carried out for these units, called K-blocks for medium-pressure lines and L-blocks for low-pressure lines. In this

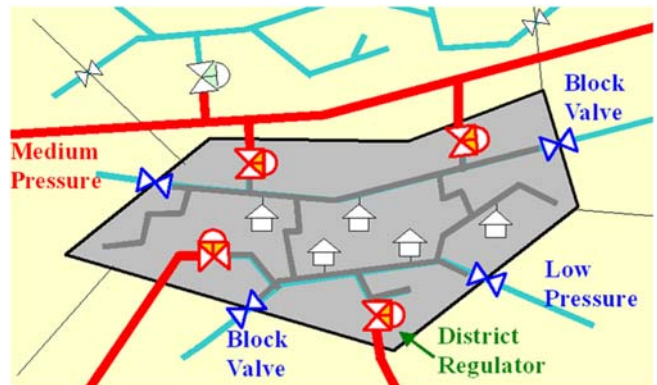

Fig. 3. Japanese district supply system

way, it is possible to separate areas with more damage from areas with less damage, minimizing the impact on the less affected areas. This method can be used to quickly shut off the gas supply to the affected areas only. For the areas where the gas supply is shut down, personnel are trained to restore the supply as early as possible.

Description of the Italian Natural Gas Supply System

The Italian gas supply system is divided into transport, storage, and distribution.

Principal components of Italian gas supply system include (Fig. 4): (1) high-pressure transmission lines; (2) M/R stations (M/R); (3) medium pressure distribution networks; (4) reduction groups; (5) low-pressure distribution network; (6) demand nodes; and (7) gas meters.

The natural gas injected into the Italian National Network comes mainly from import. It is injected into the National Network via seven entry points where the network joins up with the import pipelines (Tarvisio, Gorizia, PassoGries, Mazara del Vallo, Gela, all in Italy) and the liquefied natural gas (LNG) regasification terminals (Panigaglia, Italy, and Cavarzere, Italy). Domestically produced gas is injected into the network through 51 entry points from the production fields or their collection or treatment plants. Natural gas storage fields are also connected to the transmission network. The transportation of natural gas is a service connected with the pipelines coming from Russia, northern Europe, and North Africa, but also the regasification plants and the production and storage points located in Italy. From these points, the gas is delivered to local distribution utilities, large industries, and power plants where the gas is redelivered to the end users. Pipes used in Italy for the gas distribution network are made by polyethylene (thermoplastic resin belonging to the family of polyolefin), steel, and cast iron. However, nowadays cast iron pipes are less used due to gas leakage and cracks due to aging.

The Italian gas distribution network is divided into eight classes according to the gas pressure (Fig. 4). The RE.MI. (*Regolazione di misura* in Italian) are metering pressure reduction stations that supply natural gas in the distribution network and allow the physical connection between the high-pressure network and the distribution network to the customer. Pressure reduction systems are equipments designed to adjust the flow rate calibrating the gas supply pressure to a predetermined value, which depends on (1) supply pressure of the utilities, and (2) type of downstream network.

Network Modeling of the Gas Distribution System

SynerGEE is a commercial software for gas pipelines that analyzes close conduit networks using a set of nonlinear mathematical equations that form the model of the piping system. It uses nonlinear fluid dynamic equations, which provide levels of pressure and flow. The first Kirchhoff law is used to analyze the mesh network and is given by

$$F_j = \sum_{i=1}^{\text{facilities adjacent to node } j} F_i + FN_j \quad j = 1, \dots, NN \quad (3)$$

where F_i = facility flow; FN = node flow and the summation is for all facilities incident to node j ; j = node number in the network; and NN = number of nodes in the network.

The iterative process inside the program is solving simultaneous equations, and as the algorithms that govern these equations get closer to the solution, the program converges. In detail, the program solves for node pressure as a function of externally imposed system flows and the flow equation used. The fractional tolerance value used during a steady-state analysis to determine whether facility pressures and flows are considered solved is 0.0005. Each node equation expresses the pressure in terms of system demands,

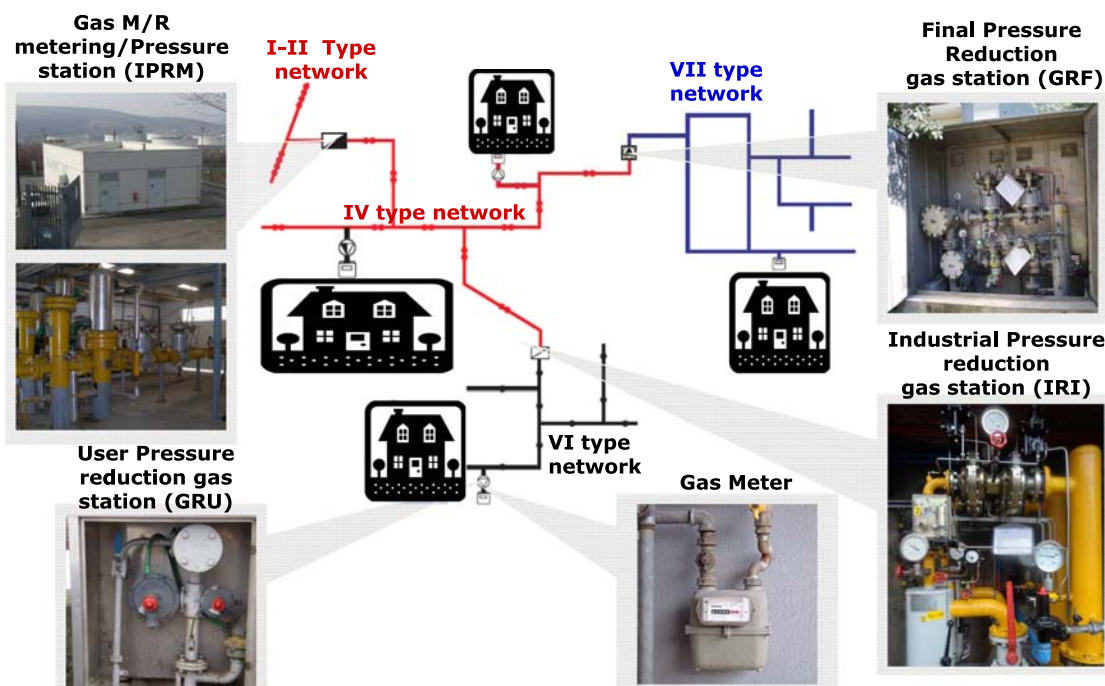

Fig. 4. Scheme of Italian gas network distribution system

supplies, and physical parameters. The flow is evaluated using the general gas flow equation in a horizontal pipe that can be obtained after some manipulations that can be found in the papers of Hyman et al. (1975) and Finch and Ko (1988)

$$F = C \frac{T_b}{P_b} D^{2.5} e \left(\frac{P_1^2 - P_2^2}{LGT_a Z_a f} \right)^{0.5} \quad (4)$$

where $C = 0.0011493$ [77.54 in the U.S. Customary System (USCS)]; D = diameter of pipe in millimeters (inches); e = pipe efficiency; G = gas specific gravity; L = pipe length in kilometers (miles); P_b = base pressure at the standard gas state in kilopascals (psia); P_1 = inlet pressure in kilopascals (psia); P_2 = outlet pressure in kilopascals (psia); T_a = average temperature in kelvins (degrees Rankine); T_b = base temperature in kelvins (degrees Rankine); Z_a = compressibility factor; and f = Fanning friction factor. Usually pipes are not horizontal, so if the slope is smooth, a correction factor H_c for the static head of fluid can be incorporated in Eq. (4) and is determined as follows:

$$F = C \frac{T_b}{P_b} D^{2.5} e \left(\frac{P_1^2 - P_2^2 - H_c}{LGT_a Z_a f} \right)^{0.5} \quad (5)$$

where

$$H_c = \frac{c_1 g (H_2 - H_1) P_a^2}{Z T_a} \quad (6)$$

where $c_1 = 0.06835$ (0.0375 USCS); Z = compressibility factor; g = local acceleration due to gravity; P_a = average pipeline pressure; H_1 = upstream hydraulic head; and H_2 = downstream hydraulic head. Once all the nonlinear continuous equation matrices related to each node have been solved and node pressures reach the value of the convergence tolerance, the flow is calculated using Eq. (5).

Simulation of Failure Modes of Pipelines

The failure of the gas distribution network depends on the number of pipe breaks per kilometer of pipe and the damage states of different facilities such as the gas metering pressure stations, the user pressure reduction gas stations, the storage tanks, and the other support facilities, which are described by their fragilities. However, after the analysis of the technical reports of ITALGAS, the seismic damage assessment of the facilities was not taken into account in the analysis, while the simulations are focusing on the seismic damage assessment of the distributing elements. Furthermore, from past observations approximately 3% of natural gas pipeline failures in the United States are due to the effect of ground movements due to

seismic events. The main seismic hazards that are responsible for pipeline failure can be described as:

- Seismic wave propagation;
- Abrupt permanent ground displacement (faulting);
- PGDs related to soil features;
- Longitudinal PGD;
- Transverse PGD; and
- Landslide; and
- Buoyancy due to liquefaction.

Because of the geological settings in the Sulmona, Italy, region, it was decided to consider only pipeline failure generated by PGD. Furthermore, the main failure modes of continuous pipelines (which are the ones used in the Sulmona, Italy, region) can be summarized as (1) tensile failure, (2) local buckling, and (3) beam buckling. Among them, the most common in steel pipes is the local buckling; therefore, the failure mode due to local buckling has been considered in the simulations. Local buckling in pipeline occurs due to local instability of the pipe wall. Once the wrinkling instability of the pressurized shell is initiated, all the subsequent wave propagation and geometric distortion caused by ground deformation tend to concentrate at these wrinkles. Thus, the local curvature in the pipe wall becomes large and leads to circumferential cracking of the pipe wall and leakage. Different disruptions due to local buckling of the gas distribution network in the towns of Sulmona, Italy, and Introdacqua, Italy, are simulated assuming pipes shear failure in the medium- and low-pressure network. Two failure locations have been considered: (1) failure in the main pipes, and (2) failure in the mesh network. The failure in the main pipes results in gas leakage from a single trunk of pipe, which is connected to the network. The shear failure in the mesh results in gas leakage from both sides of the pipes, therefore the total flow of gas released at the end of the transient discharge is equal to twice the flow released from each section.

The pipe failure mechanism has been analyzed defining the typology and the value of gas flow released in the atmosphere. The Netherlands Organization of Applied Scientific Research (TNO) model (TNO 1997) has been used to describe the disruption behavior of pressurized pipelines. The gas is modeled using the equation of ideal gases and the flow is considered adiabatic and isentropic. Three types of failure mechanisms are considered in the model (Fig. 5):

- Small break;
- Misalignment; and
- Shear Failure.

Small break failure appears when upstream pressure remains constant during the gas leakage, while shear failure appears when the pressure inside the pipes goes to zero.

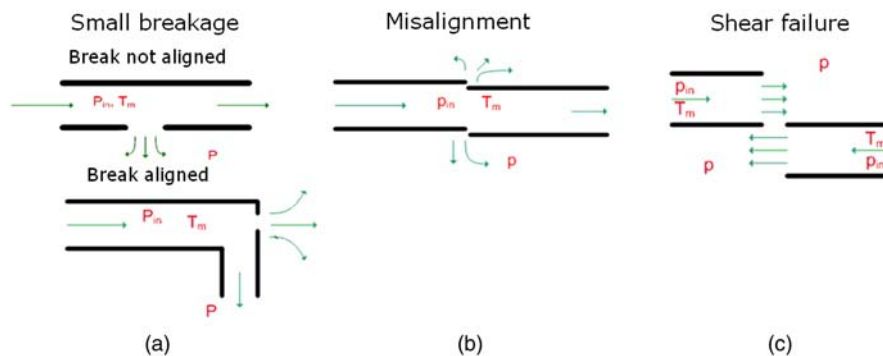

Fig. 5. Assumption of the pipeline failure mechanisms; P = downstream pressure; P_{in} = upstream pressure; T_{in} = upstream temperature: (a) small breakage; (b) misalignment; (c) shear failure

Description of the Natural Gas Distribution System in the Town of Sulmona, Italy

The natural gas distribution system that involves the municipalities of Sulmona, Italy, and Introdacqua, Italy, is managed by ITALGAS, the largest gas distribution network operator in Italy. Fig. 6 shows the gas distribution network in the municipalities of Sulmona, Italy, and Introdacqua, Italy. The connection of Sulmona, Italy, and Introdacqua, Italy, distribution medium-pressure network (MP = 64 MPa) to the national high-pressure transmission lines is operated via three M/R stations (RE.MI.), which are listed in Table 1 and shown in Fig. 6. Two of the three M/R stations in the region (IPRM1 and IPRM3) are connected to the national network of SNAM pipelines, which operates the high-pressure transmission lines in Italy. RE.MI. stations are hosting internal regulators and mechanical equipments (heat exchangers, boilers, and bowls) under which the gas undergoes the following operations and processes: (1) gas preheating, (2) gas-pressure reduction and regulation, (3) gas odorizing, and (4) gas-pressure measurement (Fig. 4). The 14 final pressure reduction gas stations (GRFs) of the gas network considered in the case study are listed in Table 2. The distribution network of the two municipalities has a total length of approximately 136.9 km, of which 109.8 km are steel-coated pipes and

Table 1. M/R Stations

Identification code	Location (Italy)	Nominal diameter (DN)	Nominal flow for a minimum pressure of 600 kPa ($10^3 \text{ m}^3/\text{h}$)	
			Maximum flow ($10^3 \text{ m}^3/\text{h}$)	
IPRM 1	Via La Torre, Introdacqua	DN50	4.6	1.734
IPRM 2	Via del Lavoro, Sulmona	DN80	11.5	0.290
IPRM 3	Via Lapasseri, Sulmona	DN100	18.5	7.380

27.1 km are polyethylene pipes. Within the two groups, distinction can be made based on the pressure distribution as shown in Table 3. Steel pipes have welded connections and are provided with a coating of bitumen-based material, but they are also currently protected cathodically with a system of sacrificial sink at impressed current, equipped with automatic feeders.

Geological Settings

The Sulmona Basin is one of the larger and more external Quaternary continental intramontane basins of the Central Apennines thrust belt, and like other intramontane basins is partially filled by continental Quaternary deposits. The chain is characterized by a complex Meso-Cenozoic paleogeographic setting and by a complicated Neogene-Quaternary structural setting. In particular, the Sulmona Valley is characterized by alluvial soils with loose natural deposits in the ancient basin lake, therefore the consolidation of cohesionless fills and loose natural deposits during earthquakes can cause PGDs. Permanent deformations can generate differential ground movements, which can result in bending and tension or compression, depending on the relative orientation of the motion and the pipeline layout.

Minor liquefaction effects were observed in the region during the 2009 L'Aquila earthquake in which small volcanoes of liquefied sand appeared in the Aterno Valley. However, the liquefaction effects in the region were rather limited and they did not interest the municipality of Sulmona, Italy. This can be partially justified because according to the empirical relationships available in literature (Galli 2000), the maximum distance from the epicenter to have a liquefaction effect is 40 km. Instead, the epicenter of the 2009 L'Aquila earthquake had a distance of 67 km from the town of Sulmona, Italy. Additionally, the analysis of the historical earthquakes catalogue in the region indicated that liquefaction effects are never observed through the centuries in the region.

From the empirical observations of the areas affected by liquefaction in Italy, it can be concluded that liquefaction appears when:

- The magnitude of the earthquake is larger than 5.5;
- The layers are less than 15-m deep;
- The water depth is near the surface (less than 3 m).

The Sulmona, Italy, region is characterized by very stable geologic conditions. The soil type is B, which corresponds to not-saturated firm soil (the water level is more than 3-m deep below the ground). So based on the previous observations and literature, it can be concluded that the liquefaction effects and the possibility of pipe break caused by PGD due to liquefaction [American Lifelines Alliance (ALA) 2001; Porter 1991; Eguchi 1983] can be neglected in the region.

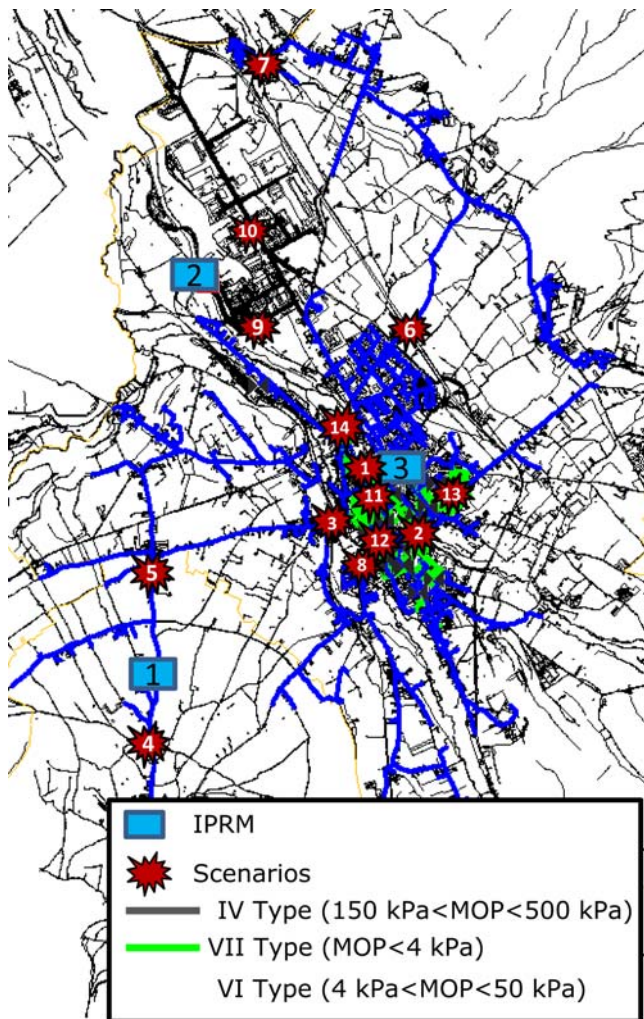

Fig. 6. Natural gas distribution network of the towns of Sulmona, Italy, and Introdacqua, Italy, with the considered scenarios (adapted from Politecnico di Torino, with permission from Politecnico di Torino)

Table 2. Final GRFs

Identification code	Location	Nominal diameter (DN)	Nominal flow (m ³ /h) for a pressure of		Simulated flow (m ³ /h) 2.5 kPa
			50 kPa	150 kPa	
GRF4	Sulmona—Via Mazzini/Trento	50	800	1,600	34
GRF5	Sulmona—Via Freda	50	800	1,600	184
GRF6	Sulmona—Via Celidonio	50	800	1,600	139
GRF7	Sulmona—Via d'Eramo	50	800	1,600	238
GRF8	Sulmona—Via Sauro	50	800	1,600	114
GRF9	Sulmona—Via Mazzini	50	800	1,600	113
GRF10	Sulmona—Via Maiella	50	800	1,600	163
GRF11	Sulmona—Via Circ.ne Orientale	50	800	1,600	205
GRF12	Sulmona—Via Pansa (ponte)	80	1,800	3,600	407
GRF13	Sulmona—PzaFaraglia	80	1,800	3,600	167
GRF14	Sulmona—PzaIacovone	65	1,250	2,500	246
GRF15	Sulmona—vleComunale	65	1,250	2,500	384
GRF16	Sulmona—PzaCapograssi	80	1,800	3,600	156
GRF17	Sulmona—via Comacchiola	50	800	1,600	164

Table 3. Pipeline Length According to the Material and Pressure

Material	Total (km)	IV Type 150 kPa < maximum operating pressure < 500 kPa	VI Type 4 kPa < maximum operating pressure < 50 kPa	VII network maximum operating pressure < 4 kPa
Steel	109.83	8.91	77.37	23.55
Polyethylene	27.11	0.39	23.04	3.67
Total	136.94	9.29	100.42	27.23

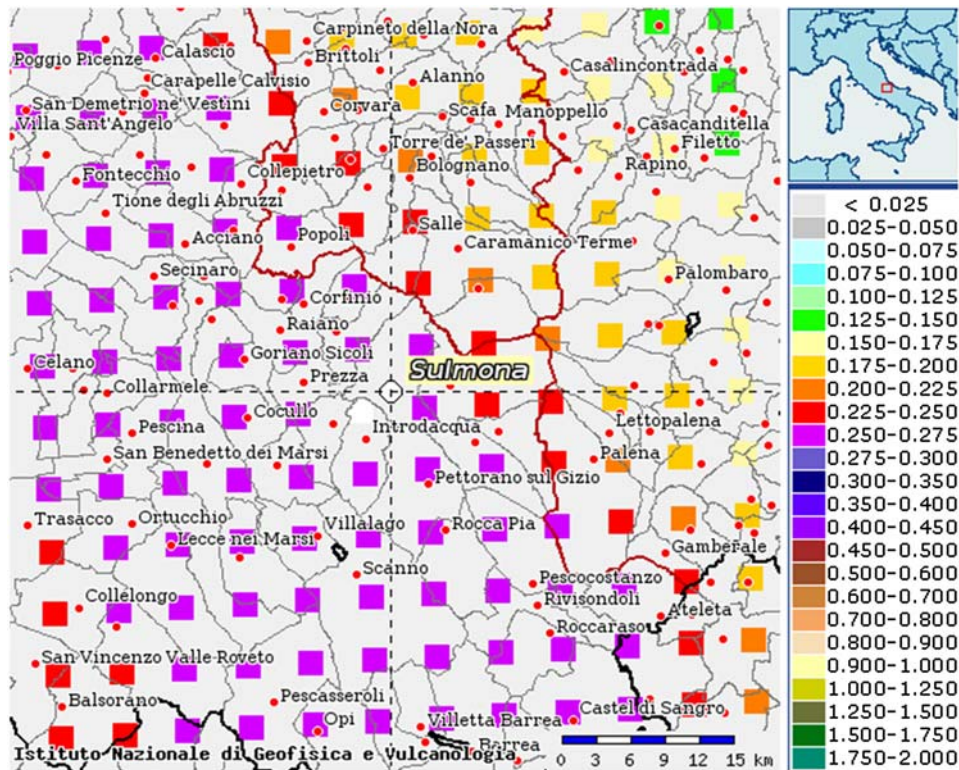

Fig. 7. Median peak ground accelerations for Sulmona, Italy, region for 10% PE in 50 years (reprinted from Meletti and Montaldo 2007, with permission from the Istituto Nazionale di Geofisica e Vulcanologia, Sede di Pisa)

Seismic Intensity

Sulmona, Italy, is located on an 800-km-long segmented normal fault system that accommodates the extensional deformations of

the Apennines chain. Very large earthquakes have occurred historically in this zone in 1349, 1461, and 1703 resulting in epicentral macroseismic intensities (MCSSs) between IX and X. According to 2003 Italian seismic code [Ordinanza del Presidente

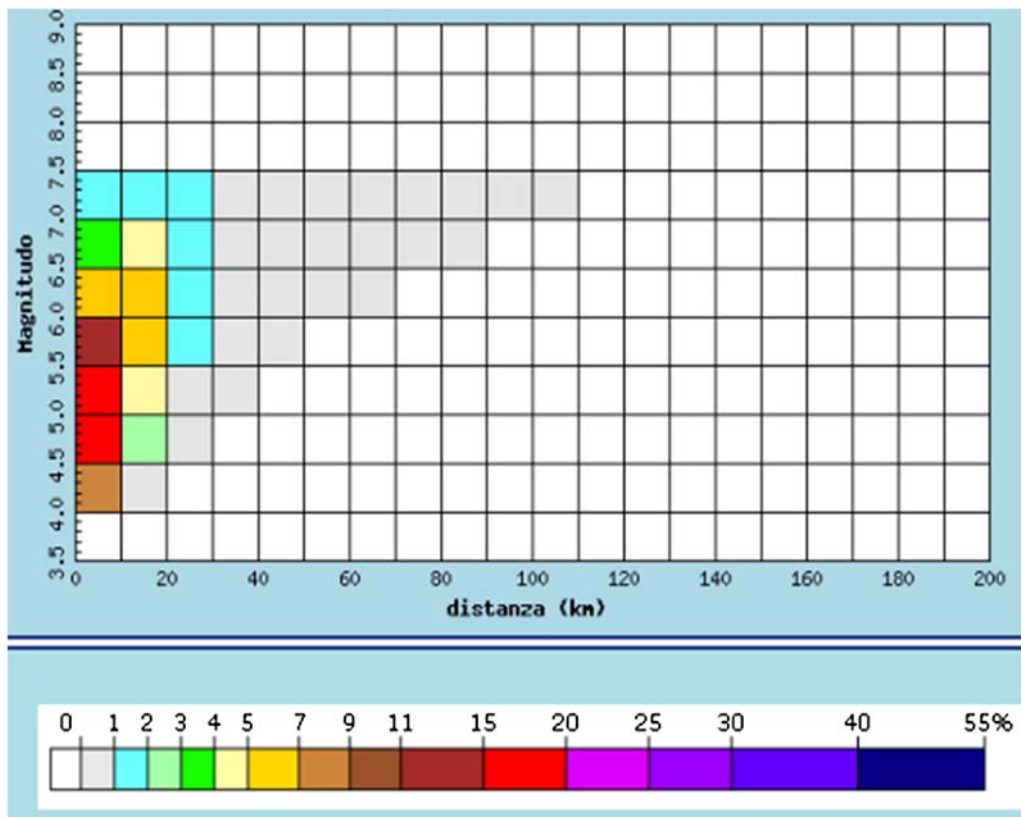

Fig. 8. Deaggregation hazard map for 22% probability of exceedance (PE) in 50 years (return period = 233 years) (reprinted from INGV 2013, with permission from the Istituto Nazionale di Geofisica e Vulcanologia, Sede di Pisa)

del Consiglio dei Ministri (OPCM)-3274 2003], the town of Sulmona, Italy, belongs to the second category zone (first category is the highest) with a peak ground accelerations (PGA) on stiff soil equal to 0.25 g. The current Italian code (NTC-08 2008) defines the PGA as a function of the geographic coordinates at the site; therefore, Sulmona, Italy, has a PGA of 0.261 g for soil type A (stiff) and for a probability of exceedance of 10% in 50 years (Fig. 7).

Probabilistic seismic hazard analysis (PSHA) provides estimates of mean annual rate of occurrence or annual probability that ground motion exceeds a specific intensity over a range of intensities; therefore, this tool has become a common seismic risk-assessment tool. However, results from PSHA are sometimes difficult for nonspecialist decision makers to interpret because the significant earthquake threats corresponding to the low probabilities of interest (e.g., 0.0004/year) represent an aggregation of earthquake events rather than one specific earthquake. Furthermore, the aggregated event cannot describe the spatial variability of damaging intensities across a region due to any particular severe earthquake, so it might not be appropriate for assessing risk of a distributed gas network system. On the other hand, a risk assessment based on scenario events avoids these difficulties, but the risk is conditioned on the occurrence of the scenario event. Appropriate scenario events can be determined from disaggregation, which identifies the dominant seismic events in the region contributing to an earthquake hazard of 22% in 50 years. The appropriate scenario event used to illustrate the network vulnerability analysis in this paper is determined from the disaggregation hazard maps provided by the Italian National Institute of Geophysics and Vulcanology (INGV) (Spallarossa and Barani 2007) (Fig. 8). The maps corresponding to a return period of 230 years (22% PE in 50 years) are selected based on the observations of the historical earthquake

catalogue in the region, which clearly shows the occurrence of an earthquake every 200–250 years. The identified dominant seismic event has a $M_w = 5.56$ with an epicentral distance of $R = 9.56$ km. The authors believe that inexperienced decision makers may more readily

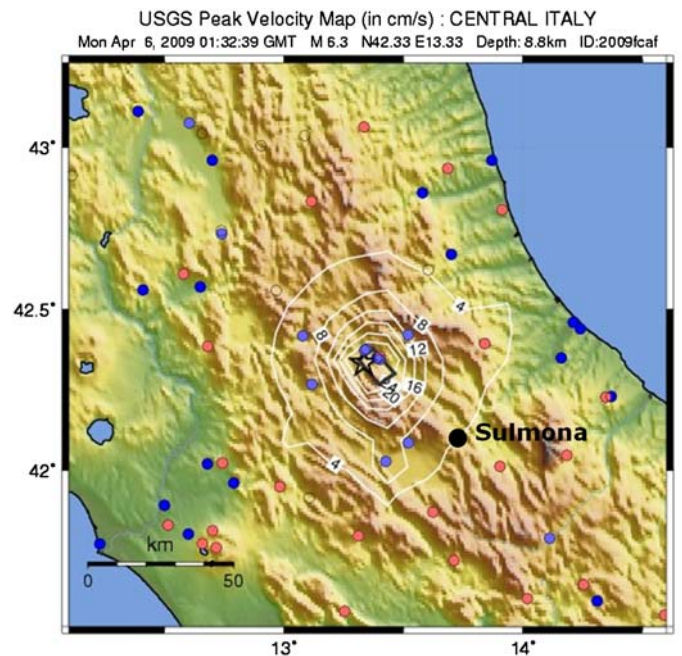

Fig. 9. Peak velocity map of April 6, 2009, central Italy earthquake (reprinted from USGS 2008)

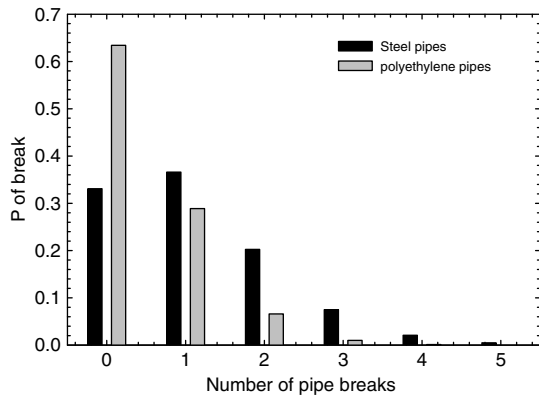

Fig. 10. Probability of pipe breaks in the Sulmona, Italy, gas distribution network

appreciate the threat to an urban area from such an event than the threat from 22% in 50-year earthquake. Then the seismic intensity at a site is determined using the Ambraseys et al. (2005) attenuation relationship, which describes the median ground motion intensity as function of M_w and R , modified by local soil conditions; therefore the final peak ground velocity (PGV) at the site is 13.91 cm/s. PGV was determined because it is a common measure of earthquake intensity for assessing distributed civil infrastructure damage.

Median PGV contour maps for the deaggregated event in the Sulmona, Italy, region are not provided from the INGV. However, the PGV contour maps of the April 6, 2009, earthquake in the region is available and shown in Fig. 9. The measured peak ground velocity at the site of Sulmona, Italy, is approximately 4 cm/s, which is lower with respect to the median value obtained at the site with Ambraseys et al.'s (2005) attenuation relationship. Because the 2009 earthquake is a single event, which can be below the median value, the PGV obtained by Ambraseys et al. (2005) has been used in the analysis.

Seismic Damage Assessment of Distributing Elements and Scenario Selection

In most of the available approaches for seismic vulnerability assessment, the pipeline damage is typically expressed in terms of the numbers of repairs occurring per unit length of pipeline. The available methods for seismic behavior of pipelines are generally based on observations about earthquake properties and pipeline response and damage. Several research projects have been developed across the world to assess the seismic loss in gas pipelines (Yamin et al. 2004). The Federal Emergency Management Agency (FEMA) developed a general methodology to assess hazard vulnerability, called *HAZUS*. However, in the *HAZUS* model it is assumed that pipeline damages subjected to earthquakes are completely independent from the pipeline size, class, and mechanical specifications. Based on previous studies, damage to pipes caused by strong ground motion in the guidelines prepared by ALA (2001) is given by

$$RR = K(0.00187)PGV \quad (7)$$

where RR = repair ratio, which is the number of pipe breaks per 305 m (1,000 ft) of pipe length; K = coefficient determined by the pipe material, pipe joint type, pipe diameter, and soil condition; and PGV = peak ground velocity in inches per second.

Pipes installed in the Sulmona, Italy, region are mainly noncorrosive steel pipes with arc-welded joints with diameters between 50 and 250 mm; therefore, following the values provided in literature (ALA 2001) it is assumed $K = 0.3$ for steel pipes and $K = 0.5$ for polyethylene small pipes.

The repair ratio, using Eq. (7) and the peak ground velocity of the dominant seismic event, is, respectively, $RR = 0.003$ for steel pipes and $RR = 0.005$ for polyethylene pipes. Under the assumption that the seismic intensity leads to a uniform demand on a gas pipe connecting two facilities, the number of pipe breaks can be expressed by the Poisson probability law

Table 4. Brief Description of the Scenarios Considered in the Analysis

Scenario	Location	Number of breaks	Nominal diameter	Diameter (mm)	Maximum operating pressure (MOP)	P (kPa)	F (10^3 m ³ /h)
1	Collapse of the bridge in via Iapasseri	1	DN200	209.1	VI network 4 kPa < MOP < 50 kPa	49.3	10.512
2	Collapse of the bridge in via Fiume	2	DN50 DN65	54.5 70.3	VI network 4 kPa < MOP < 5 kPa VII network MOP < 4 kPa	35.5 2.23	0.648 0.569
3	Collapse of the bridge in via Arabona	1	DN150	160.3	VI network 4 kPa < MOP < 50 kPa	36.3	5.616
4	Collapse in via Case del Medico	1	DN200	209.1	VI network 4 kPa < MOP < 50 kPa	49.9	10.548
5	Collapse in via Torrone	1	DN250	261.8	VI network 4 kPa < MOP < 50 kPa	48.0	16.344
6	Collapse in via Lomaccio	1	DN200	209.1	VI network 4 kPa < MOP < 50 kPa	48.0	10.404
7	Collapse of the bridge in via Bagnaturo	1	DN100	107.9	VI network 4 kPa < MOP < 50 kPa	44.1	2.700
8	Collapse of the bridge in via Stazione, Introdacqua, Italy	1	DN150	160.3	VI network 4 kPa < MOP < 50 kPa	33.8	5.544
9	Collapse in via del Lavoro	1	DN100	107.9	IV network 150 kPa < MOP < 500 kPa	500	10.224
10	Collapse in via dell'Industria	1	DN150	160.3	IV network 150 kPa < MOP < 500 kPa	500	22.572
11	Shear failure in DN50 steel pipe	1	DN50	54.5	VII network MOP < 4 kPa	2.0	0.382
12	Shear failure in DN50 and DN150 steel pipes	2	DN50 DN150	54.5 160.3	VII network MOP < 4 kPa	2.18 2.18	5.724 0.662
13	Shear failure in DN50, DN65, and DN100 steel pipes	3	DN50 DN65 DN100	54.5 70.3 107.9	VII network MOP < 4 kPa	2.25 2.25 2.25	2.610 1.109 0.666
14	Shear failure in DN65 and DN100 steel pipes	2	DN100 DN65	107.9 70.3	VII network MOP < 4 kPa	2.25 2.25	2.610 1.109

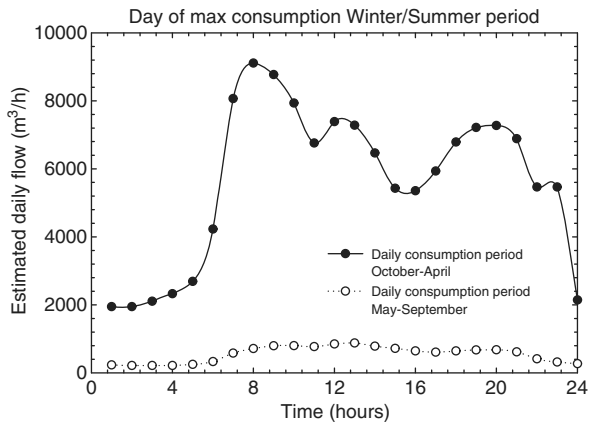

Fig. 11. Estimated daily gas flow during the day of maximum consumption in the summer and winter period

Table 5. Gas Flow and Length of Gas Network Operating after the Extreme Event

Scenario	F_I (10^3 m ³ /h)	F_{II} (10^3 m ³ /h)	L_I (km)	L_{II} (km)
1	0.164	4.053	9.297	73.508
2	0.164	9.107	9.297	136.942
3	0.164	8.927	9.297	134.200
4	0.164	8.927	9.297	127.949
5	0.164	8.781	9.297	109.652
6	0.164	6.375	9.297	120.318
7	0.164	8.174	9.297	135.038
8	0.164	9.107	9.297	136.942
9	8.942	8.967	127.645	136.942
10	8.942	9.097	127.645	134.987
11	6.374	8.435	109.713	130.715
12	6.374	8.402	109.713	124.496
13	6.374	8.519	109.713	131.599
14	6.374	8.402	109.713	134.942

$$P[N = n] = e^{-RRL} \frac{(RRL)^n}{n!} \quad (8)$$

where N = random variable denoting the number of times the event of a broken pipe occurs; $n = 0, 1, 2, \dots$ number of pipe breaks; RR = repair ratio at which the event occurs evaluated by Eq. (7); and L = length of pipe segment analyzed (expressed in terms of 1,000-ft segments); and RRL = average number of occurrences

occurring over length L of pipe that is being examined. The pipe segment is not able to deliver gas when there is at least one pipe break; therefore, the failure probability of the pipe segment can be expressed by the exponential distribution

$$P_f = 1 - P[N = 0] = 1 - e^{-RR \times L} \quad (9)$$

Even if the pipe failures are correlated, it is assumed that the events describing failure of each pipe segment are statistically independent, which is a necessary assumption to use Poisson's law in Eq. (8). The probability of having a certain number of breaks in the steel and polyethylene pipes is shown in Fig. 10. Due to computational resource limits, only 14 scenarios have been selected. In particular, the number of scenarios with one, two, or three breaks have been selected to be proportional to the respective probability given in Fig. 10. However, the extension of the steel pipes is larger than the polyethylene pipes, which is only 20% of the entire network. Therefore, assuming a weight factor of 0.2 in the probability of failure of polyethylene pipes and a weight factor of 0.8 in the steel pipes, the probability of having one break in the polyethylene pipes is below 6%. Furthermore, additional evidence that polyethylene gas pipelines are sufficiently ductile and tough to accommodate significant earthquake effects are given also by their good performance during the Kocaeli (Izmir) earthquake (O Rourke et al. 2000) and during the L'Aquila earthquake. Finally, based on the previous observations, no breaks in the polyethylene pipes have been considered. Instead, according to Fig. 10, for the steel pipes the most probable event is the one corresponding to one pipe break; therefore 10 scenarios with one break, three scenarios with two breaks, and one scenario with three breaks are selected.

Once the number of scenarios with one, two, and three breaks has been selected, then their locations need to be determined within the gas distribution network. The locations have been selected based on engineering judgment and following what is described in literature (ALA 2001).

For example, continuous pipelines that are built with rigid welded joints have shown general good performance; therefore, scenario events have been selected to address mainly leakage problems at the joint location caused by poor-quality welds or the presence of corrosion at the joint location. The scenarios have been selected also considering the structural vulnerabilities of the gas distribution network that in several points is passing over bridges. Bridge collapse scenarios (1–3, 7, and 8) have been selected because these links are considered vulnerable points of the road network and are coupled with the gas network sharing the same vulnerabilities. For all the other cases, it is assumed that what

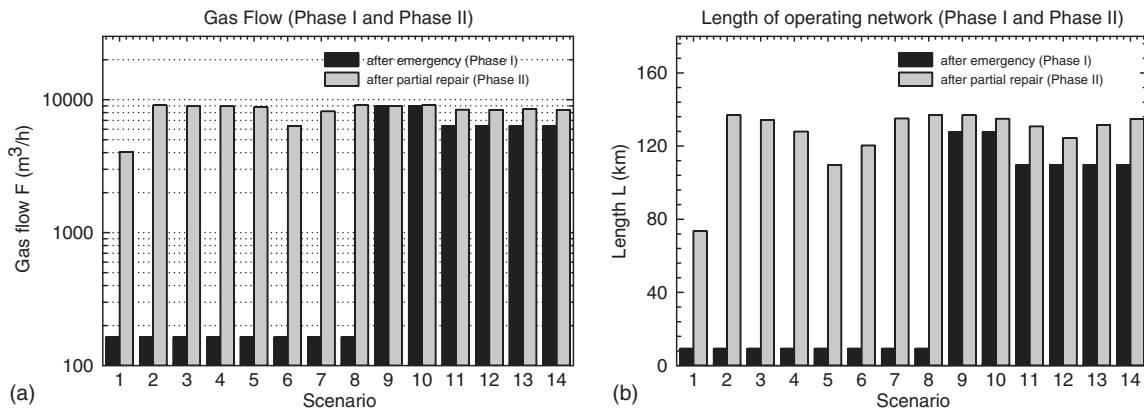

Fig. 12. (a) Gas flow; (b) length of operating network after emergency and after partial repair

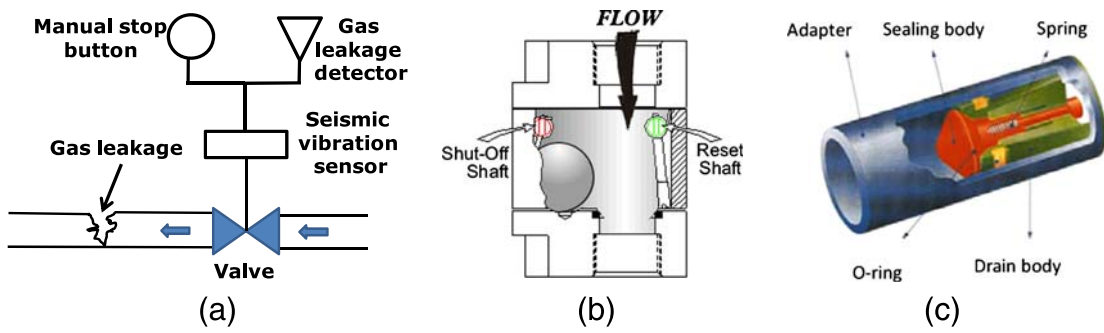

Fig. 13. (a) Emergency shutoff valves in the distribution network (adapted from Tokico Technology Ltd); (b) vertical accessible gas shutoff valves (VAGV) vertically mounted; (c) EFVs

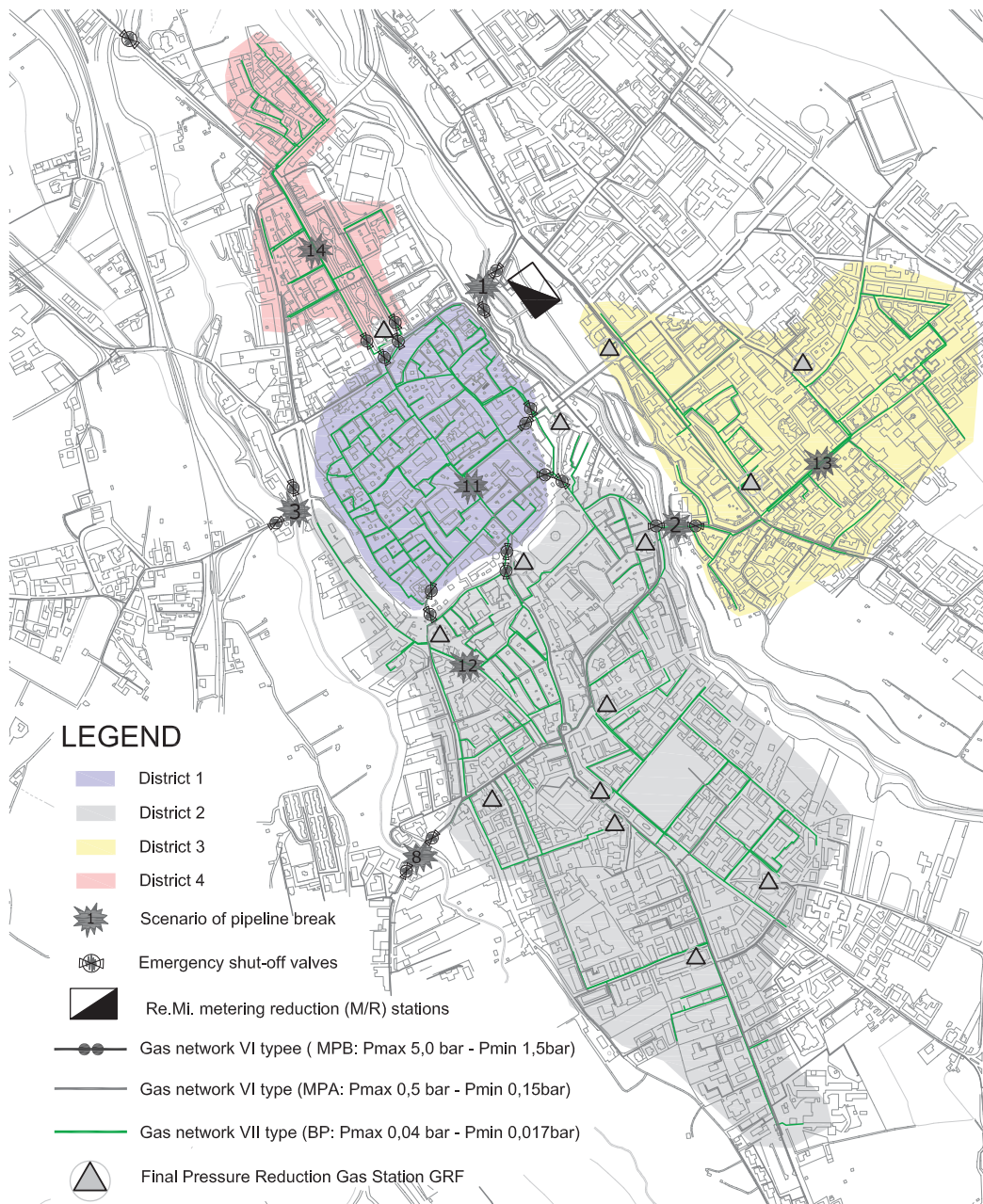

Fig. 14. Location of emergency shutoff valves in downtown Sulmona, Italy, according to the districts (adapted from Politecnico di Torino, with permission from Politecnico di Torino)

triggers the pipe failures are the permanent ground deformations and soil failures between two different soil layers during the ground shaking. For example, Scenarios 4–6 (Table 4) have been located at the intersection between the layers of alluvial deposits and ancient terraced conglomerates.

The 14 shear failure mechanisms of the gas distribution network have been selected to be part in the medium- and part in the low-pressure network. In particular, Scenarios 1 and 3–8 correspond to shear failure in pipes of Type VI [4 kPa < maximum operating pressure (MOP) < 50 kPa]. Scenarios 9 and 10 correspond to shear failure in pipes of Type IV (150 kPa < MOP < 500 kPa). Scenarios 11–14 correspond to shear failure in pipes of Type VII (MOP < 4 kPa).

In all the selected scenarios, physical damages are considered only in the pipelines, while damage to the facilities (e.g., gas reduction stations) is not considered in this paper because no damage to the gas facilities was observed in the recent 2009 earthquake that affected the same region.

Scenario Earthquake and Numerical Results

Simulations have been performed considering the maximum flow per hour evaluated during the phase of maximum gas consumption, which for Sulmona, Italy, is 9,107 m³/h considering the daily gas flow behavior shown in Fig. 11, which is evaluated from the comparison between summer and winter annual gas consumption in the region provided by ITALGAS.

In Table 2 are listed the values of gas flow, pressure, and speed in the final GRFs obtained from the numerical simulations in normal operating conditions. Then for each damage scenario shown in Fig. 6, the flow, pressure, and speed of the gas inside the distribution network was also evaluated, while the gas flow *F* resulting from the 14 damage scenarios in correspondence of the pipe breakage are given in Table 4.

In Table 5 is shown, respectively, the gas flow and the length of operating network during the two phases for the different scenarios. In the medium-pressure distribution network A (Type VI), which corresponds to Scenarios 1–8, both the flow and the length of the operating network drops drastically in the hours right after the earthquake, while significant recovery is achieved after the partial repair (Phase II) of the network [Figs. 12(a and b)]. Then, three types of protective systems have been considered for retrofitting the gas distribution network:

1. Seismic automatic gas shutoff valves (ESVs) [Figs. 13(a and b)];
2. Excess flow automatic gas shutoff valves (EFVs) [Fig. 13(c)]; and
3. Manual shutoff valves installed in correspondence of gas meter and/or underground gas connections.

The first type has a seismic sensor [Figs. 13(a and b)], which is able to shut off the network when there is an earthquake event and a predefined acceleration threshold is exceeded or if there is a remote command, is able to interrupt the gas flow in certain parts of the network to evaluate potential damage caused by earthquakes. When the valve closes, it can be opened only manually after inspection. The second type, EFVs, are inserted in the M/R stations and they work when predefined flow rates are increased due to gas leakage [Fig. 13(c)]. They can also be adopted near the end users and they shut off the flow rate if the downstream flow exceeds a certain threshold. They will automatically reopen again when the gas flow goes back to normal operating conditions. Because after an earthquake these valves will most likely experience power outages, the previously mentioned retrofit measures



Fig. 15. Flow dividers installed in a M/R station

will have rechargeable batteries or accumulators to operate during the emergency.

The ESVs have been located near bridges, which can potentially collapse after earthquakes, and in critical points inside the network. For example, the valves have been located to isolate the four districts that compose the gas distribution network of the town of Sulmona, Italy, as shown in Fig. 14. In addition, two flow dividers are installed in both M/R stations to divide the flow in different pipelines, but also to control the gas flow remotely using an electric valve that decides the flow based on the actual flow and the pressure values (Fig. 15). In this way, both the acoustic emissions and the quantity of gas used can be reduced. Finally, in all the pressure reduction gas stations are also installed valves that can control the gas flow remotely. In summary, the retrofit system that has been tested is composed of:

- 32 ESVs;
- 2 flow dividers; and
- 16 valves at the pressure reduction gas stations.

The retrofit system described previously has been tested for the 14 different scenarios; therefore, the results of the simulations are used to evaluate the resilience index before and after retrofit. The resilience values are listed in Table 6 and shown in Fig. 16.

Table 6. Resilience Index Summary for Different Scenario Events

Scenario	Before retrofit	Flow dividers	Shutoff valves	After retrofit
1	11.35	11.45	52.53	52.63
2	11.80	11.83	99.77	99.81
3	11.35	11.45	97.50	97.60
4	34.44	34.87	94.32	94.75
5	34.44	34.87	89.42	89.65
6	17.35	17.53	80.83	81.02
7	14.46	14.61	93.89	94.03
8	11.35	11.45	99.32	99.42
9	94.30	94.73	96.61	97.04
10	94.30	94.73	96.61	97.04
11	83.33	83.38	95.76	95.81
12	80.78	81.21	91.60	92.03
13	80.98	81.38	93.92	94.34
14	81.27	81.62	94.59	94.95

Note: All values are in percentages.

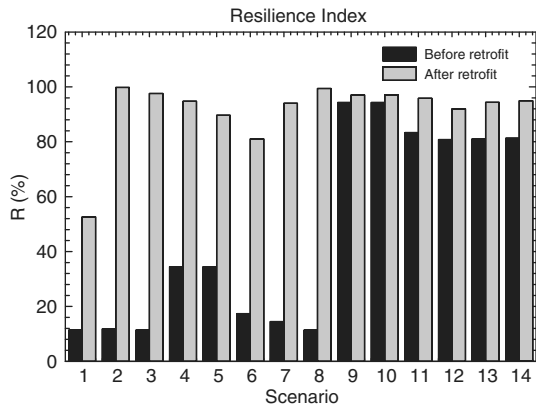

Fig. 16. Resilience index for the different scenario events before and after retrofit

Analyses show a relevant increment of the resilience index, in average of approximately 78%, especially when breaks happen in the medium-pressure A distribution network (Type VI, $4 \text{ kPa} \leq p \leq 50 \text{ kPa}$). Instead, the increments are more modest, approximately 13% on average in the low-pressure network (Type VII, $p \leq 4 \text{ kPa}$). No significant increments of resilience have been observed before and after retrofit when pipe breaks happen in the medium-pressure B distribution network (Type IV, $150 \text{ kPa} \leq p \leq 500 \text{ kPa}$) (Fig. 16). As shown in Table 6, flow dividers (Fig. 15) do not improve resilience during emergency as well as the emergency shutoff valves installed along the pipes, which improve the performance of the gas network for all the scenarios (Fig. 13). In particular, the resilience improvement is relevant in Scenarios 1, 2, and 3, which correspond to bridge collapse as shown in Fig. 16. The functionality of the gas distribution network described by Eq. (2) related to Scenario 2 is shown in Fig. 17, where the length of the operating network in the municipality of Sulmona, Italy, before and after retrofit assuming the bridge collapse in Via Fiume is also shown. From the simulated analyses, it appears that the worst scenarios correspond to shear failure on the medium-pressure

network, which has a dramatic effect in the performance of the gas network, especially right after the earthquake event. The entire network performance can be improved by the insertion of emergency shutoff valves, which allow dividing the gas network of Sulmona, Italy, in four districts as shown in Fig. 14. As a result of this division through the insertion of valves, it is possible to improve the resilience index of the gas distribution network of about 80%, especially when failure happens in a vulnerable element of the network like bridges or shear failure of pipeline in the medium-pressure network.

The analyses performed require a number of assumptions on the spatial correlation of the seismic intensity. Epistemic uncertainties in response to distributing elements and in strong ground motion are not modeled, nor are any covariance in seismic intensity that may exist at adjacent points within the network considered. Furthermore, also the inclusion in the analyses of the interdependency effects among other infrastructure systems could have affected significantly the serviceability and resilience of the gas network. Future research, which is beyond the scope of this paper, will focus on extending the model to determine the potential impact of these additional factors on gas network serviceability and on the mitigation of seismic risk.

Concluding Remarks

The reliability assessment of infrastructure systems providing power, natural gas, and potable water is an integral part of societal preparedness to unforeseen hazards. In particular, earthquake safety of gas networks has attracted great attention in recent years since significant amount of damage was observed during recent earthquakes. The paper proposes a performance assessment methodology for gas distribution networks, which includes the restoration process right after an extreme event such an earthquake. A resilience index is proposed and used for measuring the capacity to sustain a level of functionality or performance of a gas distribution network over a given period range. The gas distribution network of the municipalities of Introdacqua and Sulmona, two small towns in the center of Italy that were affected by the 2009 earthquake,

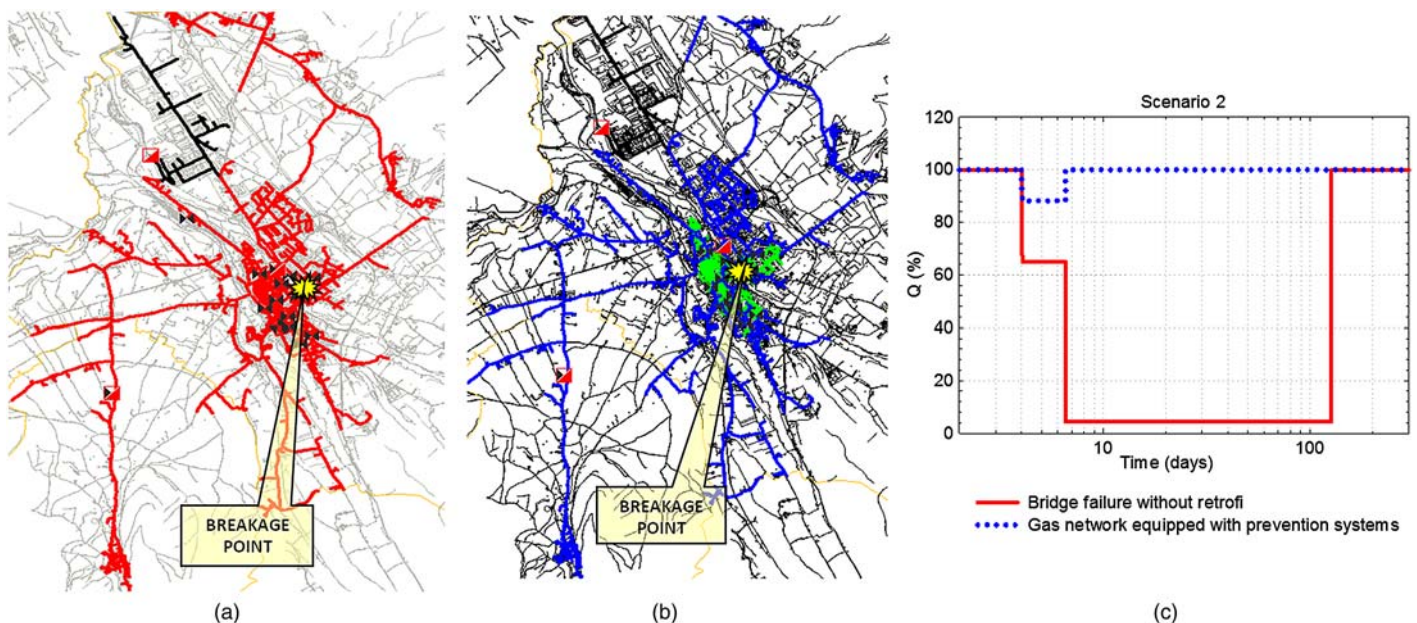

Fig. 17. Bridge collapse (Scenario 2) of gas network with and without prevention systems (data from Politecnico di Torino)

have been used as case study to show the implementation issues of the proposed methodology. Several scenarios with different failure mechanisms are simulated using the software SynerGEE. The numerical results showed that to ensure an acceptable delivery service, it is crucial to guarantee the functionality of the medium-pressure gas distribution network in the postearthquake response. Furthermore, the best retrofit strategy is to include emergency shut-off valves along the pipes to prevent gas leakage caused by earthquake damage.

Acknowledgments

The research leading to these results has also received funding from the European Community's Seventh Framework Programme—Marie Curie International Reintegration Actions—FP7/2007-2013 under the Grant Agreement n° PIRG06-GA-2009-256316 of the project ICRED—Integrated European Disaster Community Resilience.

References

- Adachi, T., and Ellingwood, B. R. (2008). "Serviceability of earthquake-damaged water systems: Effects of electrical power availability and power backup systems on system vulnerability." *Reliab. Eng. Syst. Saf.*, 93(1), 78–88.
- Ambraseys, N. N., Douglas, J., Sarma, S. K., and Smit, P. M. (2005). "Equations for the estimation of strong ground motions from shallow crustal earthquakes using data from Europe and the Middle East: Horizontal peak ground acceleration and spectral acceleration." *Bull. Earthquake Eng.*, 3(1), 1–53.
- American Lifelines Alliance (ALA). (2001). "Seismic fragility formulations for water systems Part 1—Guidelines." ASCE & FEMA, 96.
- Bruneau, M., et al. (2003). "A framework to quantitatively assess and enhance the seismic resilience of communities." *Earthquake Spectra*, 19(4), 733–752.
- Chen, W. W., Shih, B.-J., Chen, Y.-C., Hung, J.-H., and Hwang, H. H. (2002). "Seismic response of natural gas and water pipelines in the Ji-Ji earthquake." *Soil Dynam. Earthquake Eng.*, 22(9–12), 1209–1214.
- Choo, Y. W., Abdoun, T. H., O'Rourke, M. J., and Ha, D. (2007). "Remediation for buried pipeline systems under permanent ground deformation." *Soil Dynam. Earthquake Eng.*, 27(12), 1043–1055.
- Cimellaro, G. P. (2013). "Computational framework for resilience-based design (RBD)." Chapter 36, *Seismic risk analysis and management of civil infrastructure systems*, S. Tesfamariam and K. Goda, eds., Woodhead Publishing, Sawston, Cambridge, U.K.
- Cimellaro, G. P., Fumo, C., Reinhorn, A. M., and Bruneau, M. (2009). "Quantification of seismic resilience of health care facilities." *MCEER Technical Rep.-MCEER-09-0009*, Multidisciplinary Center for Earthquake Engineering Research, Buffalo, NY.
- Cimellaro, G. P., and Reinhorn, A. M. (2011). "Multidimensional performance limit state for hazard fragility functions." *J. Eng. Mech.*, 137(1), 47–60.
- Cimellaro, G. P., Reinhorn, A. M., and Bruneau, M. (2010a). "Framework for analytical quantification of disaster resilience." *Eng. Struct.*, 32(11), 3639–3649.
- Cimellaro, G. P., Reinhorn, A. M., and Bruneau, M. (2010b). "Seismic resilience of a hospital system." *Struct. Infrastruct. Eng.*, 6(1–2), 127–144.
- Cimellaro, G. P., Solari, D., Renschler, C., Reinhorn, A. M., and Bruneau, M. (2013). "Community resilience index integrating network interdependencies." *Proc., 2013 Structures Congress (SEI 2013)*, ASCE, Reston, VA.
- Eguchi, R. T. (1983). "Seismic vulnerability models for underground pipes." *Proc., earthquake behavior and safety of oil and gas storage facilities, buried pipelines and equipment*, ASME, New York, 368–373.
- Finch, J. C., and Ko, D. W. (1988). "Tutorial—Fluid flow formulas." *PSIG Annual Meeting*, Pipeline Simulation Interest Group, Houston, TX.
- Galli, P. (2000). "New empirical relationships between magnitude and distance for liquefaction." *Tectonophysics*, 324(3), 169–187.
- Han, Z. Y., and Weng, W. G. (2011). "Comparison study on qualitative and quantitative risk assessment methods for urban natural gas pipeline network." *J. Hazard. Mater.*, 189(1–2), 509–518.
- HAZUS-MH Version 1.1 [Computer software]. Federal Emergency Management Agency and U.S. Army Corps of Engineers, Washington, DC.
- Hyman, S. I., Stoner, M. A., and Karnitz, M. A. (1975). "Gas flow formulas—An evaluation." *Pipeline Gas J.*
- Italian National Institute of Geophysics and Vulcanology (INGV). (2013). "The National Institute of Geophysics and Vulcanology." (http://esse1-gis.mi.ingv.it/s1_en.php) (Jan. 15, 2013).
- Jeon, S. S., and O'Rourke, T. D. (2005). "Northridge earthquake effects on pipelines and residential buildings." *Bull. Seismol. Soc. Am.*, 95(1), 294–318.
- Jo, Y.-D., and Crowl, D. A. (2008). "Individual risk analysis of high-pressure natural gas pipelines." *J. Loss Prevent. Process Ind.*, 21(6), 589–595.
- Markowski, A. S., and Mannan, M. S. (2009). "Fuzzy logic for piping risk assessment." *J. Loss Prevent. Process Ind.*, 22(6), 921–927.
- Meletti, C., and Montaldo, V. (2007). "Stime di pericolosità sismica per diverse probabilità di superamento in 50 anni: valori di ag." *Progetto DPC-INGV S1, Deliverable D2*, (<http://esse1.mi.ingv.it/d2.html>) (Jan. 30, 2014).
- Montiel, H., Vilchez, J. A., Arnaldos, J., and Casal, J. (1996). "Historical analysis of accidents in the transportation of natural gas." *J. Hazard. Mater.*, 51(1–3), 77–92.
- NTC-08. (2008). "Nuove Norme Tecniche per le Costruzioni (NTC08)." Consiglio Superiore dei Lavori Pubblici, Ministero delle Infrastrutture, Gazzetta Ufficiale della Repubblica Italiana, Roma, Italy (in Italian).
- Ordinanza del Presidente del Consiglio dei Ministri (OPCM)-3274. (2003). "Ordinanza 3274. "Primi elementi in materia di criteri generali per la classificazione sismica del territorio nazionale e di normative tecniche per le costruzioni in zona sismica"." Consiglio Superiore dei Lavori Pubblici, Ministero delle Infrastrutture, Roma, Italy, (in Italian).
- O'Rourke, T. D., et al. (2000). "Water, gas, electric power, and telecommunications performance." *Earthquake Spectra*, 16(S1), 377–402.
- Pojansek, K., Bono, F., and Gutierrez, E. (2012). "Seismic risk assessment of interdependent critical infrastructure systems: The case of European gas and electricity networks." *Earthquake Eng. Struct. Dynam.*, 41(1), 61–79.
- Porter, K. (1991). "Performance of water supply pipelines in liquified soil." *Proc., Fourth US-Japan Workshop on Earthquake Disaster Prevention for Lifeline Systems*, U.S. Department of Commerce, Washington, DC, 3–17.
- Scawthorn, C., and Johnson, G. S. (2000). "Preliminary report—Kocaeli (Izmir) earthquake of 17 August 1999." *Eng. Struct.*, 22(7), 727–745.
- Shinozuka, M., Cheng, T.-C., Feng, M., and Mau, S.-T. (1999). "Seismic performance analysis of electric power systems." *Research progress and accomplishments 1997-1999*, Multidisciplinary Center for Earthquake Engineering Research, Buffalo, NY.
- Spallarossa, D., and Barani, S. (2007). "Disaggregazione della pericolosità sismica in termini di M-R-ε. Progetto DPC-INGV S1, Deliverable D14." (<http://esse1.mi.ingv.it/d14.html>) (Jan. 20, 2014).
- SynerGEE Gas Software 4.3.2 [Computer software]. Inst Gas Engineers and Managers Charnwood Wing, Loughborough, Leicestershire, U.K.
- TNO. (1997). *TNO—Methods for the calculation of physical effects—Yellow book*, Publicatierieeks Gevaarlijke Stoffen, Delft, Netherland.
- U.S. Geological Survey (USGS). (2008). "The 2008 U.S. Geological Survey (USGS) national seismic hazard maps." (<http://earthquake.usgs.gov/research/hazmaps/>) (Jan. 15, 2013).
- Yamin, L. E., Arambula, S., Reyes, J. C., Belage, S., Vega, Á., and Gil, W. (2004). "Earthquake loss estimation for a gas lifeline transportation system in Columbia." *13th World Conf. on Earthquake Engineering, Paper No. 2941*, International Association of Earthquake Engineering (IAEE), Tokyo, Japan.
- Yuhua, D., and Datao, Y. (2005). "Estimation of failure probability of oil and gas transmission pipelines by fuzzy fault tree analysis." *J. Loss Prevent. Process Ind.*, 18(2), 83–88.