



BUFFALOENGINEER

SPRING 2010

Alumni

- Scott Stevens: Engineer of the Year
- UB Engineers at Basketball
- NPR's Flatow Speaks on Science

Faculty

- Govindaraju, Mitin & Qiao Made Fellows
- Ruckenstein Publishes Collected Works

Students

- AIAA Team Earns NASA Spot
- Curry & Llop Visit Asia
- Engineers Week
- Order of the Engineer

Development

- Ephraim & Anna Marie Garcia
- Richard & Patricia Garman
- Patrick P. Lee Foundation
- Mike & Mary Salvadore
- Jim & Mary Smist



◀ Andre Filiatrault in Haiti



◀ Pierre Fouche

Filiatrault & Fouche Address Haiti Quake

Takeuchi Wins National Medal & SUNY Distinction



Bloch Funds Scholarships

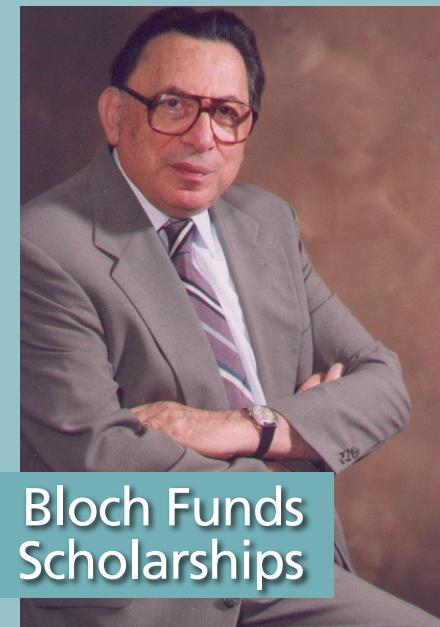



Dean Stenger with construction site of new engineering building in background

In the last few months, the School of Engineering has continued to show strong and steady signs of growth in several important areas.

Our school received \$2.4M in gifts during the last quarter, much of which will go to developing the school's new building. For their generosity, we thank the Patrick P. Lee Foundation, Mary and Michael

Salvadore, and Anna Marie and Ephraim Garcia. Our scholarship funds have received contributions from distinguished alumni and friends, notably, **Erich Bloch**, Patricia and Richard Garman, and Mary and **Jim Smist**. Please see the Development section.

Construction on the school's new building shows exciting progress. A large crew has been present for several weeks lifting girders into place to form the building's frame. A second shift of workers is closing

the structure. Please visit: <http://www.eng.buffalo.edu/newbuilding/livecam/nblc3/>.

Growth is also evidenced in that several of our enrollments are at an historical high. Please see the table in the Education section for some statistics.

UB's School of Engineering and Applied Sciences is having a strong positive influence on the Western New York (WNY) region's businesses and economy. For example, many regional businesses and organizations have engaged with The Center for Industrial Effectiveness and our New York State Strategic Partnership for Industrial Resurgence (SPIR). Local manufacturing processes and information systems have improved, as faculty develop new technologies in collaboration with companies, and as UB Engineering graduates and interns contribute their technical knowledge to the regional work force. Through SPIR, Erie County has made Lean-Six Sigma the cornerstone of its reform effort, with a return of over 1500% of the county's original investment. We are proud of our school's beneficial impact on WNY.

Please read on to learn more about UB Engineering's exciting recent research and school-wide activities.

Sincerely,

Dean Harvey G. Stenger Jr.

Inside This Issue: Cover Stories 3 Alumni 4 Students 7 Education 11 Faculty & Staff 12
 Research 14 Development 20 Pre-College 22 Class Notes 23

Cover photo captions and credits:

Top: CSEE Professor and MCEER Director Andre Filiatrault (in orange vest) visits the Wayom Timoun orphanage in Port-au-Prince, Haiti. His AIDG-MCEER team deemed it structurally safe for re-entry, though it was not built to withstand seismic resistance. 64 orphans were living outside the structure when the structural engineers visited. To Filiatrault's left, with white mask, is team member Jean-Philippe Simon, of the US Department of Defense. Photo: MCEER

Top, inset: CSEE PhD student and Haitian citizen Pierre Fouche is working on developing multi-hazard engineering systems for extreme events applications in multiple-hazard prone regions like his home country, Haiti. His rare stature as a Haitian earthquake engineer allowed him to address the media after Haiti's recent devastating earthquake. Photo: Doug Levere

Bottom left: BME, CBE, Chemistry, and EE Greatbatch Professor, SUNY Distinguished Professor Esther Sans Takeuchi after accepting the National Medal of Technology and Innovation from President Obama. Photo: Associated Press

Bottom right: UB Engineering alumnus and donor Erich Bloch (BS EE '52, Hon. ScID '85) has made a ten-year commitment to UB Engineering scholarships.

Departmental Research Highlights:

- CBE:** CBE's Errington: Molecular Simulation Models Roughness and Wetting Behavior, p. 14
 CBE's Swihart Group Researches Silicon Quantum Dots for *In Vivo* Applications, p. 16
- CSE:** CSE's Zhong: INPAC Encourages Cooperation in Wireless Networks, p. 16
- CSEE:** CSEE's Atkinson on Modeling Resource Sheds, p. 15
 CSEE Researchers Contribute to Opening of World's Largest Earthquake-Safe Building, p. 15
 CSEE's Mosqueda Tests Building Collapse with Innovative Model, p. 17
 CSEE's Sadek Helps Design Traffic Text Alert System, p. 17
- EE:** EE's Litchinitser Developing Metamaterials, p. 14
- ISE:** ISE Research for US Office of Naval Research and Air Force Research Lab, p. 18
 ISE's Wu on Safety of Phone Use While Driving, p. 19
- MAE:** Protean Software by MAE's Kesavadas and Tactus Team, p. 19
 MAE's Ringuette in Hummingbird's Vortex, p. 18



Join **UB Believers** and help create the future of our communities—at the university, local and state levels. UB Believers is an advocacy group that supports the University at Buffalo's 2020 growth plan. Your voice will be part of a growing chorus dedicated to strengthening Western New York's economy and quality of life. To learn more, please visit: ubbelievers.buffalo.edu/ubbelievers/home.

Takeuchi Earns Top Recognitions: US National Medal of Technology and Innovation and SUNY Distinguished Professor



"the very best of American ingenuity... inspires a new generation of thinkers and innovators"

Esther Sans Takeuchi, a National Academy of Engineering member and Greatbatch Professor in Advanced Power Sources Research, in the departments of BME, CBE, EE and Chemistry, received the National Medal of Technology and Innovation at a White House ceremony. The medal honors her outstanding contributions to technology that contribute to the improved health and quality of life for millions of people in the United States and the world. Takeuchi's research and achievements in power sources for biomedical devices have made longer lasting and more reliable life-saving technologies possible. In President Obama's words, she is one of the awardees who embodies "the very best of American ingenuity and inspires a new generation of thinkers and innovators." She has been awarded 142 patents.

Concurrently, her achievements earned her a promotion by the State University of New York's trustees to the system's highest academic designation of SUNY Distinguished Professor.

Takeuchi joined UB Engineering's faculty in 2007. For 22 years, she was Executive Director of Battery

Research and Development and Chief Scientist at Greatbatch, Inc., where she led a team of scientists and engineers focused on power source research and innovation. There, Takeuchi developed the tiny lithium/silver vanadium oxide battery, helping to bring implantable cardiac defibrillators (ICDs) into production in the late 1980s. Now over 300,000 of these units are implanted every year, the majority of which are powered by the battery system that Takeuchi and her team developed and improved.

Presently, Takeuchi is researching power sources to improve cycle life, decrease size, and increase longevity for applications such as sensors, satellites, electric vehicles, and medical devices. Her current research, with husband SUNY Distinguished Teaching Professor Kenneth Takeuchi (Chemistry), and EE and CBE Research Assistant Professor **Amy Marschilok**, involves fine-tuning, at the atomic level, the materials used to power battery systems, with *in-situ* generation of silver nanoparticles. Takeuchi explains that by designing the bi-metallic material at the atomic level, "the change in its conductivity and performance is inherent to [it]. We didn't add supplements to achieve that – we did it by changing the active material directly." The research is made possible with funding by the National Institutes of Health and the US Department of Energy.

Greatbatch Professor Esther Sans Takeuchi
Photo by James Ulrich, UB

CSEE's Filiatrault Leads United Nations-Appointed Post-Quake Assessment Team in Haiti



Andre Filiatrault

CSEE Professor and MCEER Director **Andre Filiatrault** led a team of French-speaking structural engineers to assess the safety of remaining structures, particularly hospitals and schools, in Port-au-Prince, Haiti after the recent quake left many of the capital city's buildings unsound. The group, a partnership with the Appropriate Infrastructure Development Group (AIDG), was the United Nations' (UN)-appointed interim lead emergency engineering support unit for organizing and initiating building assessments there.

While in Haiti from January 21 to 28, Filiatrault said that the team developed a framework which the UN adopted as a formal building-assessment process going forward. The team busily addressed as many building inspection requests as they could, working with UN vehicles and military escorts.

The team followed the ATC-20-1 (Applied Technology Council-20-1: Field Manual: Post-earthquake Safety Evaluation of Buildings) tagging procedures:

Continued on page 17

CSEE's Fouche Responds to Media

Pierre Fouche, a Haitian CSEE PhD candidate, has been working to contribute to bridging the knowledge gap about multi-hazard system engineering and design. His family was spared during the recent quake, but regretfully, Fouche foresaw that an impending earthquake would cause vast damage in his home country.

Fouche has been studying earthquake engineering at UB since 2006, with support from UB and the UB President's Office. A former recipient of the CSEE Dean's Fellowship, he is now completing his dissertation under CSEE Professor **Michel Bruneau**.



Pierre Fouche

Both Filiatrault and Fouche have received wide national media attention, in ABC News' 20/20, *The Buffalo News*, CNN, National Public Radio, *Newsweek*, and *Wired*, to name a few outlets. Notably, Fouche was named a CNN Intriguing Person for January 21, 2010. Fouche's recently published CNN story, "A Plan to Reconstruct My Country," was a call to action for Haiti's rebuilding. Of his many suggestions, he identified the need for a comprehensive urban-development plan with adherence to international multi-hazard building codes, because the country had none – of special importance in Haiti, which is so susceptible to multiple hazards: earthquakes, hurricanes, storm surges, and tsunamis. He also noted the need to create lifelines for vital emergency response and recovery systems – including health care, power, transportation, and water.

UB Engineering Alumni Association Board of Directors

Officers:

- *James D. Boyle, President (BS CIE '78)
- *Joseph S. Frandina, PE, Vice President (BS CIE '78)
- *Stephen P. Buechi, Treasurer (BS CIE '93, MEng '95)
- *Michael J. Dray, Secretary (BS CE '04)

Members:

- *Michelle C. Barker (BS CE '99, MS CIE '07)
- *Peter Buechi, PE (BS '68 MS '70 CIE)
- *Jeffrey Dudek (BS CIE '00)
- *John T. Kociela, PE (BS CIE '68)
- *Anthony S. Markut (BS IE '80)
- *Brian J. Peer (BS CE '05)
- *Richard A. Rink, PE (BS CIE '80)

In Memoriam

UB Engineering offers its sincere sympathy to family, friends, and classmates of those alumni who have recently passed away.

William T. Ames, BS IE '52

UB Engineering mourns the tragic loss of **Saiba K. Ansari** (BS ME '10), her sister, **Faaiza Ansari**, (BS '06, Biochemical Pharmacology, UB School of Medicine), and their father **Mohammad N. Ansari** (BS ME '78). The three perished in a recent house fire.

Karl E. Avenarius, BS CIE '70

Jeffrey J. Brown, BS EE '82

Michael E. Case, BS ME '61

Albert J. Gerritz, BS ME '50

Gary J. Grabenstatter, BS ME '73

William T. Klementowski, BS EngSci '74

Paul Lautensack, BS ME '53

Ronald F. Lochocki, BS EE '60

Ernest S. Okonski, MS EE '71, PhD IE '73

James Rogers, BS ME '64, was President, Kehr-Buffalo Wire Frame Co. and Rogers Industrial Spring, Inc. Gifts in his memory may be sent to UB Foundation, School of Engineering, P.O. Box 730, Buffalo, NY 14226.

Richard H. Wiley, BS ME '51

Henry L. Wisniewski, MS IE '83

Leonard I. Wolffe, BS IE '50

Scott Stevens Awarded Engineer of the Year



L to R: Dean Harvey Stenger, Mike Dray, Coleen Stevens, Scott Stevens, Brian Peer, and Michelle Barker

Annually the UB Engineering Alumni Association's (UB EAA) Engineer of the Year award goes to a UB Engineering alum or closely affiliated person with distinguishing activities in alumni, community, business, and professional affairs. This year's award went to **Scott D. Stevens** (BS CIE '79), PE, founder and CEO of Dimension Fabricators, Inc. (Schenectady, NY), a manufacturer of concrete reinforcing steel products for complex construction projects.

Stevens, a director on the Concrete Reinforcing Steel Institute's board, is a Dean's Advisory Council member. He and his wife Coleen (UB Physical Therapy '79) have faithfully supported UB Engineering, and recently the couple pledged a generous gift to the School's new building, where the courtyard will be named in their honor.

Scott Stevens' career began as a facilities engineer for the space shuttle program at Lockheed Martin. In 1984, he founded Dimensions. Under his direction, the company has become highly regarded for its fabrication and delivery solutions on grand-scale and challenging concrete reinforcing projects. Dimensions has produced parts and assemblies for many of the northeastern United States' sizable highway bridges, among other large east coast civil engineering projects. The company recently announced that it will relocate to the former Super Steel Schenectady plant in Glenville, NY, to accommodate its growth.

The award was presented by Dean **Harvey G. Stenger Jr.**, P.E. and UBEEA's ***Michael J. Dray** (BS CE '04), ***Brian J. Peer** (BS CE '05), and ***Michelle C. Barker** (BS CE '99, MS CIE '07).

Deanie Hedrick Honored



The UB Engineering Alumni Association honored Deanie Hedrick for her service to the UBEEA. Pictured from l to r: Michelle Barker, Brian Peer, Mike Dray, Sean Hedrick, Deanie Hedrick, Bill Hedrick, Jim Boyle, Joe Frandina, and Tony Markut

We Want Our Future!



A grassroots space-based outreach/advocacy initiative run by students, for students.



UB Engineering Alums Create Educational Initiative

"We Want Our Future" is a nationwide science, technology, engineering and technical (STEM) educational outreach project led by **Bradley Cheetham** (BS '09 AE & ME), with several current UB Engineering students and alums. The project asks students to envision themselves exploring beyond the Earth's atmosphere by depicting future space travel on postcards, and asks students to accept the challenge of pursuing STEM subjects. Aerospace students and alums embody what these students strive to become. Please visit www.WeWantOurFuture.org to learn more about becoming involved.

Bradley Cheetham is currently an AE graduate student at University of Colorado, Boulder's Colorado Center for Astrodynamics Research.

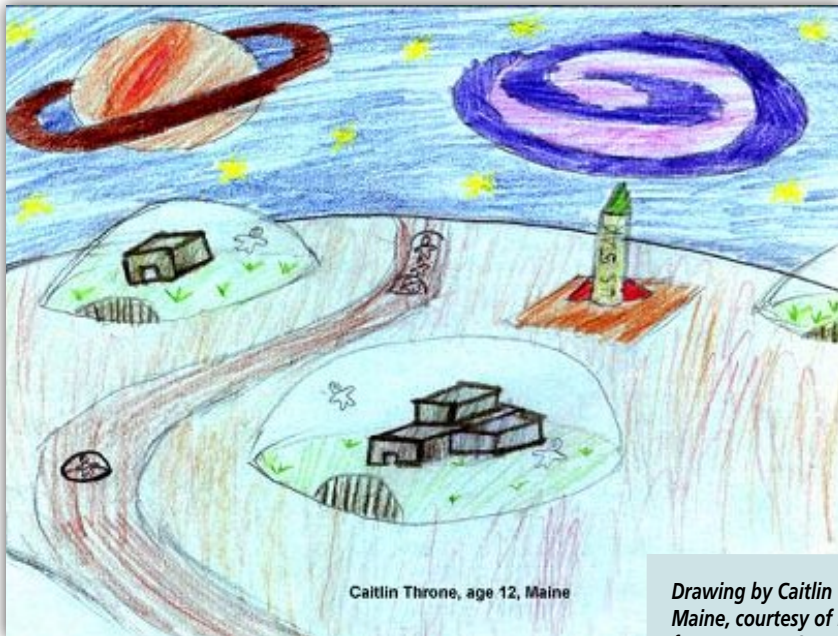

Caitlin Throne, age 12, Maine

Drawing by Caitlin Throne, age 12, Maine, courtesy of Kids to Space, from WeWantOurFuture.org

Hire UB Engineering Co-op and Intern Students

We encourage our alumni and industrial partners to consider employing UB Engineering students through our Co-operating Engineering Education Program.

Co-op students have completed their junior year, including coursework in their major, and many have business-success skill training through the Engineering Career Institute. They are prepared for challenging, value-added technical assignments.

Internships are also available.

Please consider employing one or more of these students.

For more information, contact:

Dean C. Millar, Assistant Dean
412 Bonner Hall, (716) 645-0971
University at Buffalo
dcmillar@buffalo.edu
www.eng-intern.buffalo.edu

Since the early 1990s, the **UB Engineering Alumni Association** has carried on a tradition of giving scholarships to deserving undergraduate students through the **UB Engineering Alumni Association Scholarship Fund**. Please consider continuing this tradition with your donations, which are essential to supporting the fund. Together, we can all work to promote UB Engineering's excellence.

Checks should be addressed to the **UB Foundation** and sent to:

External Affairs
UB Engineering Office
412 Bonner Hall
University at Buffalo
Buffalo, NY 14260-1900

UB Career Services: An Alumni Resource

- **Job hunting?** Get job search assistance and access to online postings and interviewing opportunities.
- **Seeking top candidates for your company?** To arrange on-campus interviews or showcase your organization, e-mail jobs@buffalo.edu.
- **Have advice for current college students?** Join the **Meet-a-Mentor** program.

Please visit: www.ub-careers.buffalo.edu.
Career Services Office, 259 Capen Hall, North Campus, University at Buffalo
(716) 645-2231

Alumnus and NPR Host Flatow Speaks on Science



Ira Flatow (BS IE '71), award-winning science journalist, author, and host of NPR's Science Friday program, recently spoke on the importance of science in our world. He signed copies of his latest book, *Present at the Future: From Evolution to Nanotechnology, Candid and Controversial Conversations on Science and Nature*. The event took place at the Buffalo & Erie County Public Library's (BECPL) Central Buffalo library branch, in commemoration of the 150th anniversary of Charles Darwin's *On the Origin of Species*, for which UB and BECPL collaborated on *Darwin: The Origin of Influence*, an exhibition of rare books and archival materials.

UB Engineering Alumni Association at Basketball and Spirit Award

UB Engineering alumni, students, faculty, staff and friends enjoyed the 23rd Annual Engineers Day at UB Basketball, where UB Men played vs. Kent State at Noon and UB Women played vs. Akron at UB's Alumni Arena.

The men won and were televised on ESPNU and the women lost a close game.

The UBEEA hosted a between-game party on the Alumni Arena floor.

The Engineering Student Club Spirit Award was given to Tau Beta Pi (see bottom of this page).



UBEEA board member Michelle Barker with her husband



UBEEA Board Member and past president Peter Buechi (center, cap) with his family



Alumni Membership

The UB Alumni Association Thanks Its Members

Thank you to all Engineering School alumni who are members of the UB Alumni Association (UBAA)! With your support, we have reached a milestone: the largest dues-paying membership in history.

Not a member? Join now to begin saving on events, online shopping, UB merchandise and much more. When you join the alumni association, you're making a statement that you're true blue, you support UB and you want to make a difference. (And, you'll get all the benefits membership has to offer!) Show your pride and support an organization whose purpose is to provide support for you.

Find out more online at http://www.eng.buffalo.edu/alumni_membership.php or call UBAA at 1-800-284-5382.

Wherever this symbol  appears in *Buffalo Engineer*, a dues-paying alumni member has been named.



Become an Alumni Ambassador

If you hold an undergraduate degree from the School of Engineering, and you would like to share your experiences and help attract the best students to the school, you can volunteer as an Alumni Ambassador. Ambassadors represent UB by attending college fairs, hosting receptions, or by sharing their experiences with potential students. To register and learn more, please visit www.ubambassadors.ning.com.

Current Engineering School Alumni Ambassadors are: **Adriane Cavanagh** (BS ME '83); **Chincy Matthew** (BS EE '05); **Gregg McDonald** (BS IE '94); **Matthew Miller** (BS CSE '07); **Karianne Paolo** (BS IE '00); **Christopher Richard** (BS ME '95); **John Rog** (BS IE '85); **John Wilkinson** (BS CBE '98); and **Mark Zabaldo** (BS ME '94).

Engineering Alumni Association Spirit Award



Tau Beta Pi's (TBP) NY Nu chapter earned this year's Spirit Award, presented by the UB Engineering Alumni Association (UBEEA) to the Engineering School club or society with the greatest presence at UBEEA's basketball event. Here, Senior Associate Dean and UBEEA Liaison Robert Barnes presents the Spirit Award check to TBP chapter President Jenna Curry.



Sport Your School Pride with Alumni Apparel

The UB Engineering Alumni Association and the UB Alumni Association are proud to announce the debut of the www.iLoveUB.com web store, your source for UB School of Engineering gear. Please visit to see a new line of School of Engineering apparel, t-shirts, caps, hoodies, and more!

UB Undergraduate AIAA Project Selected for NASA SEED Program

The UB American Institute of Aeronautics and Astronautics (AIAA) student chapter team is one of just 14 undergraduate student groups selected by the National Aeronautics and Space Administration (NASA) to test an experiment of their own design in simulated weightlessness this summer.

The Formation Flyers team is comprised of **Bradley Booth** (AE, ME), **Sandra Czarnecki** (AE), **Thomas Guile** (Physics), **Nikeale Haynes** (undeclared), **Dave Pohl** (AE, ME), Team Captain **Nathan Roscup** (AE, ME), and **John Sisti** (AE, ME). MAE Professor **John Crassidis** and MAE graduate student **Richard Linares** (BS AE '09) are advisors. The students will test and evaluate their experiments aboard an aircraft modified to simulate a reduced-gravity environment. The aircraft will fly approximately 30 roller-coaster-like climbs and dips during experimental flights to produce periods of weightlessness and hyper-gravity ranging from 0 g to 2 g.

The team's research, entitled, "Relative Attitude Determination for Satellite Formation Flying," proposes orienting two satellites toward a common reference point using the simple information obtained from light-emitting diodes and position-sensing diodes. The team's experiment investigates concepts in relative spacecraft navigation using a formation of two satellites and a third arbitrary point, relevant to formation flying in satellites. The method will be performed with information from the visual navigation system. Using these sensors, an algorithm can be used to compare each spacecraft's relative orientation to each other. Using a third point, each spacecraft will determine its relative rotational orientation.

The team's project includes an outreach effort to high school students on careers in engineering.

The UB AIAA Formation Flyers team with their advisors, MAE Professor John Crassidis (in white shirt) and MAE graduate student Richard Linares (in light blue shirt, rear left).



Curry and Llop: UB Engineering Student Ambassadors to Asia



Jenna Curry (above) in front of the Great Wall of China and Chris Llop (right)



Last year the State University of New York (SUNY) invited a handful of Chinese students from China's earthquake ravaged Sichuan province to study for free in New York State. To show their gratitude, the Chinese government partially sponsored a Discovering China program for SUNY students, in which undergraduate ME student **Jenna Curry** participated. Curry was Tau Beta Pi's NY Nu chapter vice president of external affairs and is completing the term as chapter president. During the trip, Curry had the opportunity to visit Tiananmen Square, the Great Wall of China, and Peking University in Beijing, among other places.

From the modern and westernized city of Beijing, the group traveled to Nanchong in the Sichuan province, where they met Chinese university students, observed a more traditional Chinese city, and learned of Chinese culture, including some kung fu and Chinese language. In addition to forming friendships, Curry states, "In this age of globalization and increased international interaction, this experience was invaluable and will be beneficial throughout my life and career as an engineer."

2009 Udall Scholar **Chris Llop** (EE) visited Singapore this winter as part of Student Affairs' SLIDE (Student Leadership International Dialogue and Exchange) Program. Llop is the UB Student Association Environmental Department founder and director and Engineers for a Sustainable World chapter relations director. The SLIDE program offers student leaders the opportunity to engage with student leaders in other cultures so that they may thrive as leaders in the global community. SLIDE activities explore cultural differences and similarities, team-building, and allow students to learn about leadership paradigms within the context of different social, political, cultural and economic systems in Singapore.

UB partnering institutions Singapore Institute of Management (SIM) and Nanyang Technological University (NTU) organized the program activities, with SIM as the host institution.

While in Singapore, Llop gave a presentation on American leadership models to his SIM and NTU counterparts, and he is completing a SLIDE project and presentation this semester.

Order of the Engineer at 2010 Engineers Week

This year's Engineer's Week was a well-organized and successful series of fun and educational events, thanks to participants and organizer Carolyn Pokora, the Student Association's Engineering Club Coordinator.

A highlight of the week was the Order of the Engineer ceremony, during which graduating seniors are welcomed into the engineering community as inductees, and take an oath of professionalism. Inductees are pictured and listed by discipline.

For more pictures of Engineers Week, please see the last page.

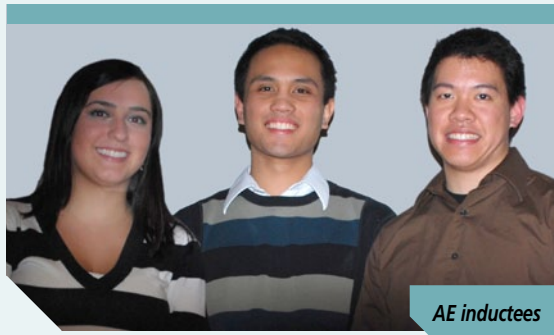

AE inductees



IE inductees



CE inductees



CIE inductees

AE: *Christina M. Scanlon*

AE and ME: *Rita M. Groetz; Carl C. Javier; Daniel A. Leake; Jordan L. Matthews; Michael A. Meller; Lavan Shanmugarajah; Andrew Xiao*

CE: *Tawfiq Afif; Andrew M. Bodratti; Kimberly M. Cryan; Jaime L. Egnaczak; Brett J. Van Groenewoud; Kevin J. Kapuza; Alan L. Knoell; Emily K. Leitsch; Chad D. Lemke; Michael P. Maggio; Diya M. Mathew; Nicholas V. McLasky; Swati Murthy; Nikita Petrosyan; Evan M. Schlaich; Nicholas M. Tojek*

CEN: *Nor Azriah Aziz; Mita Kher; Prashanto J. Kochavara; Eric D. Nagler*

CIE: *Shaimaa B. Abdullah; Salim Ayalp; Tara L. Boyanski; James D. Boyle; Brianna M. Ciccone; Tom R. Cosgro; Lucas S. Cotterell; Benjamin Katz; Kevin C. Marciniak; Eric J. Romeiser; Daniel S. Schneider; Claude A. Semexant, Jr.; Scott A. Sidell; Kenny T. Sim*

CS: *Derek E. Chong; Jamie A. D. Szafran*



CSE inductees



EnvE inductees



EE inductees



ME inductees

CS/EE: Kyle A. Eudene

EE: Stephen M. Allen; Khamdan N. Alrobaie; James R. Barron; Mary Clare T. Clark; Kelli K. Dimon; Showkat Hossain; Alina S. Joseph; Steve S. Kaitharath; William E. King; Eric E. Knaak; Christopher J. Llop; Timothy C. Plain; Sonam Purohit; Hazem H. Qassem; Martin J. Salisbury; Colin J. Schumacher; David L. Schwab; Mary Roman Solomonyuk; Jessica M. Tornabene

EnvE: Andres F. Alzate; Kelly A. Duval; Lauren M. Schifferle; Matthew J. Widay

EPh: Brian J. Frey

IE: Jeffrey Dauoheung; Nur Faazila Mohamad Sadik; Elizabeth M. Uhl; Tien Hwei Wee; Yankit M. Wong

ME: Jennifer L. Blersch; John J. Bornheim; Matthew P. Bryden; Gregory P. Cummings; Jenna M. Curry; Justin K. Dyke; Joseph L.J. Houle; Erica N. Kerr; Tae-Wook Lee; Melissa R. Maze; Mathews M. Nelpurackal; David M. Olson; Aditya Sachan; Eric J. Salerno; Ryan P. Spies; Jibi N. Varughese; Matthew G. Wagner; Katie J. Weber; Kyle J. Young



Tau Beta Pi New York Nu Chapter Inductees

Tau Beta Pi's New York Nu chapter was formed at the UB School of Engineering and Applied Sciences in 1967.

A dinner with parents and friends and a ceremony were held to honor the Fall 2009 Tau Beta Pi NY Nu Chapter inductees.



(L to R): Organizing committee at TBP NY Nu chapter's fall 2009 induction ceremony, shown with Dean Stenger (third from right); member Jeff Ackerman; member Zack Marzec; Vice President of Internal Affairs, Chih Yong Lee; past President Christopher Llop; Kris Schindler; and current President, Jenna Curry.

Inductees by class:

Juniors: Jeremy Battesh, Colin Conner, Brian Dolan, Kyle Doyle, Kathleen Gajewski, David Galuski, Daniel Gifford, Alexis Gruschow, Daniel Levine, David Lloyd, Claire Lochner, Gregory Maloney, Claire Mctaggart, Edward Papaj, Adonis Pimienta-Penalver, Luke Scannell, Daniel Snitzer, Joseph Sodaro, Colton Steiner, Brandon Tarney, John Vallone, Joanne White, Andrew Wise.

Seniors: John Barker, Jennifer Blersch, Matthew Bowers, Wai-Fong Chan, Kyle Eudene, Joel Gabrielson, Prashanto Kochavara, Gary Lachina Jr., Te Ngee Lim, David Mastriano, Diya Mathew, Swati Murthy, Daniel Potter, Ryan Schuab, Jessica Tornabene, Wai Lun Tsang, Brett van Groenewoud, Christopher Wells

Graduate Students: Mitali China, Richard Hyde, Andrew Newman, Biswajit Sarkar

Current NY Nu chapter officers: Jenna Curry, President; Chih Yong Lee, Vice President of Internal Affairs; Marcia Torrico, Corresponding Secretary; Nicholas Fortenbery, Recording Secretary

Current Advisors: Senior Associate Dean, *Robert Barnes, Chief Advisor; Brandon Brown, Advisor; MAE SUNY Distinguished Teaching Professor Roger Mayne, Advisor; Thomas Pinkham, District Director

TBP's NY Nu chapter also hosted its annual Honors Recruitment Dinner and Tech Fair, which received gold sponsorship from Cobham Mission Systems Division, Orchard Park, NY, and generous support from these honor societies: Alpha Pi Mu, Chi Epsilon, Eta Kappa Nu, Pi Tau Sigma, and Sigma Gamma Tau. Pictured, l to r: Jim Talty, Assistant Director of Engineering, Cobham; Gary Thomasulo, Oxygen Systems Engineering Manager, Cobham; President Jenna Curry; past President Chris Llop.



CBE's Sarkar Earns Best Paper Award

A research article co-authored with CBE graduate **Biswajit Sarkar** as primary author was recognized by the Indian Institute of Mineral Engineers (IIME) as the "Best Paper Published on Beneficiation." The article, "Study of Separation Features in Floatex Density Separator for Cleaning Fine Coal," (*International Journal of Mineral Processing*) was co-authored by A. Das and S.P. Mehrotra. The paper evaluates an autogeneous density separator in the beneficiation of low grade coal fines. The research will help in improving the value extraction from low grade natural resources. Sarkar is working towards his PhD under the direction of CBE's Distinguished Professor and Director of Graduate Studies, **Paschalis Alexandridis**.



CBE Undergraduate Research Fair

The CBE Department hosted its Undergraduate Research Fair this winter, with presentations from undergraduate students that participated in CE 498 Undergraduate Research and Creative Activity. Listed here are the students alphabetically by name, with their research projects and advisor name.

Bernard Afriyie: "Chemical Processes of Silicon Nanoparticles" (Professor Swihart); **Ebunoluwa Ayandele:** "Layer by Layer (LBL) Assembled Multilayer Formation and Growth Studies" (Professor Tsianou); **Daniel Demonte:** "Hydrogen Flame-Driven Production of Non-Oxide Nanoparticles" (Professor Swihart); **Chyi Chin Hew:** "Biodegradable Nanoparticles by Thiol-Ene Miniemulsion Reaction" (Professor Cheng); **Krystal Lajoie:** "Functional Si Nanoparticles" (Professor Swihart); **Lye Lin Lock:** "Heterologously Expressed G-Protein Coupled Receptor in Yeast" (Professor Park); **Yoon Sing Yap:** "Tumor Microenvironment and pH-Sensitive Brush Polymer-Drug Conjugates" (Professor Cheng)

EAS 140: Green Engineering



An EAS 140 project team tests a wind turbine of their own design.

Freshmen this past fall were introduced to a Principles of Engineering course (EAS 140) emphasizing open-ended problem solving of real-world problems.

Students were challenged, for example, with sizing the number of solar panels required to supply electricity needs on campus, or with designing and fabricating a small-scale wind turbine. Through their own research, project teams developed conceptual and quantitative models, identified data needs, obtained and analyzed data, and produced final reports and oral presentations.

The projects were centered on the theme of Alternative/Renewable Energy, relating to the National Academy of Engineering's "Grand Challenges" for the future. This theme guided the course's main objectives: developing students' ability for self-directed problem-solving, and a sense of the manner in which engineers approach problems. The course featured guest lecturers from the School of Engineering, University Facilities, and industry, who lent their expertise to the projects, while representatives from the Dean's Advisory Council held a panel for students. A team of over 40 upper-class peer leaders mentored the 100+ freshman project teams.

UB Engineering's Presence Abroad

UB Engineering students have the opportunity to expand their horizons while studying abroad, with an ongoing program at the University of Technology at Troyes, France (UT), while students at Istanbul Technical University, Turkey (ITU) can apply themselves to a UB Engineering dual degree program. Dean **Harvey Stenger** recently visited these schools.

The UT summer program began in 2003 and has run every year since. Students from Troyes have come to UB to earn their master's, while an average of 17 UB undergraduate students have attended each year at Troyes, participating during the summer after the freshman year.

To date, the ITU program, also begun in 2003, has involved Turkish students attending UB through a dual-degree program. Unaffiliated with the program but of related interest, UB Engineering faculty CSEE Professors **Michael Constantinou** and **Andrew Whittaker** have collaborated with ITU counterparts, and CSEE Associate Professor **Stuart Chen** did a Fulbright and taught there. The program has had 115 CIE students in five cohorts, with 18 graduates so far; and 39 EnvE students in three cohorts.

MAE's Chung and Mayne: Teaching and Building Partnerships in Viet Nam



MAE's Chung (center, pink and black jacket) and Mayne (rear, second from left) at TNUT

MAE Professor **Deborah Chung** and MAE's SUNY Distinguished Teaching Professor **Roger Mayne** recently visited Viet Nam's **Thai Nguyen University of Technology (TNUT)**, to lecture to TNUT faculty members on education and teaching methodology. The two also lectured to students and briefly met some parents of university students.

Their travel was funded by the Vietnamese government through TNUT, a large public university with an engineering focus. TNUT selected UB to partner in developing a pioneering American-style undergraduate ME program that mimics UB's ME curriculum, after several administrators and professors made site visits to review various American ME engineering programs. MAE faculty members

participate by curriculum transfer, teaching methodology transfer, and by initial teaching. The Advanced Program, coordinated here by MAE Professor and ME Undergraduate Director **Robert Wetherhold**, is in its second year, with one freshman and one sophomore class already engaged at TNUT.

In Hanoi, Chung and Mayne also attended a large conference of those representing American and Vietnamese academic institutions, on "Building Partnerships in Higher Education – Opportunities and Challenges for the US and Vietnam," where Professor Chung spoke on technology education. The conference was sponsored by the US Embassy in Hanoi.

Summer Courses

This year the Engineering School is pleased to offer its most comprehensive set of summer school course offerings ever, with selections for undergraduates and graduate students. UB Engineering undergraduate students and students from other schools who will be in the local area are welcome to enroll, as are incoming freshmen and transfer students. Graduate students will have the opportunity to select from the school's greatest number of summer distance learning offerings to date.

If you or someone you know is interested in learning more, please visit the informational web site at www.eng.buffalo.edu/summer/.

Please note: there must be sufficient enrollment for a course to be offered.

EngiNet™ Offerings

EngiNet™ is principally a graduate-level distance learning program.

We offer courses year-round in the following areas:

- Civil, Structural and Environmental Engineering
- Computer Science and Engineering
- Electrical Engineering
- Engineering and Applied Sciences
- Industrial and Systems Engineering
- Mechanical and Aerospace Engineering

See our website www.eng.buffalo.edu/EngiNet for class lists and more program information.

For additional information, contact the EngiNet™ Office at (716) 645-6865 or enginnet@eng.buffalo.edu.

Fall 2009 Enrollment

Undergraduate	2444
Masters	827
PhD	418
Total	3689

The above numbers include the greatest graduate enrollments in the departments of AE, CBE, CSE, EE, IE, and ME; and the greatest undergraduate enrollments in CBE and CSEE.

Faculty Achievements

CBE's **Paschalis Alexandridis**, UB Distinguished Professor and Director of Graduate Studies, presented an invited lecture on "Self-Assembly of Amphiphilic Block Copolymers" at the Fifth Sino-US Conference of Chemical Engineering in Beijing, China. While there, he also presented seminars at the Key Laboratory of Green Process and Engineering, Institute of Process Engineering, Chinese Academy of Sciences, and at the College of Materials Science and Engineering, Beijing University of Chemical Technology.

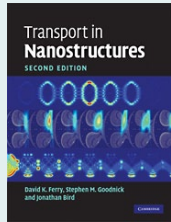

A revised second edition of **Jonathan Bird's** *Transport in Nanostructures* (Cambridge, 2009), has been published. Co-authors are David K. Ferry and Stephen M. Goodnick, both of Arizona State University. The work provides a much-needed update on the latest experimental research into mesoscopic devices and develops a detailed theoretical framework for understanding their behavior. Beginning with the key observable phenomena in nanostructures, the authors describe quantum confined systems, transmission in nanostructures, quantum dots, and single electron phenomena. The book will be of great interest to graduate students taking courses in mesoscopic physics or nanoelectronics, and researchers working on semiconductor nanostructures.

CSEE Professor **Michel Bruneau** has written a novel entitled *Shaken Allegiances*, published by CePages Press. The novel spans 48 hours in a world askew, just after a devastating earthquake has struck and isolated Montréal Island in the dead of an icy winter, one week before a referendum on Québec's secession from Canada. To learn more, visit <http://www.michelbruneau.com/MB-Literature.htm>.

CSE Lecturer **Mike Buckley** (BS EE '78) and the Center for Socially Relevant Computing (CSRC) are profiled on Microsoft's research web site. Buckley co-founded the center in 2008 with financial and software support from Microsoft External Research. The CSRC seeks to attract more students, particularly women and minorities, to technology by showing the CS profession to be one in which students can solve significant, real-world problems. CSE's Teaching Assistant Professor **Kris Schindler** (BS '93 MS '96 PhD '01 EE) is included in the write-up, which can be seen here: http://research.microsoft.com/en-us/collaboration/focus/cs/src_solveproblems.aspx.

BME and EE Chair and Professor **Alexander Cartwright** was elevated to IEEE senior member status. Cartwright leads the Laboratory for Advanced Spectroscopic Evaluation; he is Director, Institute for Lasers, Photonics and Biophotonics (ILPB); Co-Director, Electronics Packaging Laboratory; and is affiliated with: UB2020 Integrated Nanostructured Systems; Center for Spin Effects and Quantum Information in Nanostructures (CSEQuIN); and Center for Unified Biometrics and Sensors (CUBS). Cartwright also recently received an NIH grant for a research project entitled "Multifunctional Image Guided Surgical Platform."

CSE Professor **Chang Wen Chen** was a keynote speaker on "Mobile and Networked Video: A Challenging New Era," at MobiMedia 2009, in London, England. The talk presented some multi-faceted challenges for emerging mobile and networked video applications, and examined a new approach based on distributed source coding principles to demonstrate that a distributed source coding based approach is promising for video encoding, decoding, and processing for various contemporary video applications.

CSEE Professor **Stuart S. Chen** was interviewed in *Engineering News-Record* about bridge information modeling and why it's needed to integrate design and operations management. The article, "Ten Minutes with the Godfathers of Bridge Information Modeling," may be read at <http://enr.construction.com/people/interviews/2009/0812-ChenShirole.asp>.

CSE Assistant Professor **Murat Demirbas** was a key organizer of the 28th IEEE Symposium on Reliable Distributed Systems in Niagara Falls, NY. Demirbas served as the symposium's local arrangements chair; chaired the session on Database and Storage; and presented on "A Holistic Solution to Pursuer-Evader Tracking in Sensor Networks," with then-graduate student **Xuming Lu** (MS CS '09) and CSE Professor **Chunming Qiao**.

CSE's UB Distinguished Professor **Venugopal Govindaraju** was recognized as an Association for Computing Machinery (ACM) Fellow for contributions to fundamental knowledge and innovations in the field of handwritten document image analysis, recognition, and retrieval.

UB Distinguished Professor and CBE Department Chair **David Kofke** was elected Vice President of the Computer Aids for Chemical Engineering (CACHÉ) Corporation. CACHÉ is a 40-year-old non-profit organization that promotes cooperation among universities, industry, and government in the development and distribution of computer-related educational aids for the chemical engineering profession.

EE's SUNY Distinguished Professor **Vladimir Mitin** has been recognized as an American Association for the Advancement of Science Fellow for distinguished contributions to the field of nanotechnology, particularly for research and education in nanoelectronics, nanophonics, and phonon enhancement of electronic and optoelectronic devices.

EE Professor **Dmitris Pados** has accepted the position of EE Associate Chair.

CSE Professor **Chunming Qiao** was elevated to an Institute of Electrical and Electronic Engineer (IEEE) Fellow for contributions to optical and wireless network architectures and protocols.

CSEE Professor and ERIE (Ecosystem Restoration through Interdisciplinary Exchange) IGERT Director **Alan J. Rabideau** was named to a National Academy of Sciences' National Research Council panel on hazardous waste (HW) sites with "recalcitrant" contamination that hinders their closure. The panel will issue a report in about 32 months. The panel's project, "Future Options for Management in the Nation's Subsurface Remediation Effort," will explore ways to improve HW management at thousands of sites where subsurface contaminants create problems for site closure, possibly threatening public water supplies.

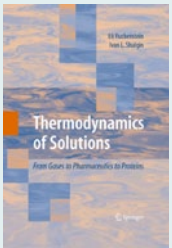

CBE's Distinguished Professor, NAE member **Eli Ruckenstein** and longtime collaborator Ivan Shulgin have collected Ruckenstein's most influential works into several reprint volumes, each focusing on a theme from Ruckenstein's contributions to diverse research areas. The first volume, *Thermodynamics of Solutions: From Gases to Pharmaceuticals to Proteins*, is now in print (Springer, 2009). The second volume, on nanodispersions, is near completion.

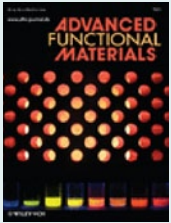

A publication on photoluminescent silicon nanocrystals and their applications, from CBE's group led by Professor **Mark Swihart**, Director, Integrated Nanostructured Systems, was featured on the cover of *Advanced Functional Materials*. The work was a collaboration with Ph.D. student Anoop Gupta, visiting from Germany, and his advisor, Hartmut Wiggers.

Luminescent nanocrystals may play important roles in biological imaging for cancer diagnosis; in low-cost solar cells; and in efficient light-emitting diodes. Swihart recently gave invited lectures on this research in Wuhan, China; ENEA, near Rome, Italy; Kyoto, Japan; ETH in Zurich, Switzerland; and in the US at the University of Massachusetts, and Tulane University.

CBE Assistant Professor **E. Manolis Tzanakakis** delivered a paper on *Guided Cardiogenic Commitment of Human Embryonic Stem Cells for Heart Tissue Engineering* at the American Institute of Chemical Engineers' (AIChE) Annual Meeting in Nashville, Tenn. Co-authored with CBE students **Donghui Jing** and **Abhirath Parikh**, the paper examines how cell therapies may provide an attractive alternative to current treatments of heart failure by helping regenerate damaged cardiac tissue. Tzanakakis was also an invited lecturer on "Systems for Large-Scale Expansion and Differentiation of Human Embryonic Stem Cells" at a conference on stem cells and biotechnology at Amrita University, Cochin, India.

CSEE Professor **Andrew Whittaker** is now Director of CSEE's Structural Engineering and Earthquake Simulation Laboratory (SEESL). In this capacity, he also assumes the role of PI for UB's George E. Brown, Jr. Network for Earthquake Engineering Simulation (NEES). Many thanks to former SEESL Director Professor **Andre Filiatrault** for his effective leadership.

CSE Professor, Center of Excellence in Information Systems Assurance Research and Education (CEISARE) Director **Shambhu Upadhyaya** was a key organizer of IEEE's Symposium on Reliable Distributed Systems, held at Niagara Falls, together with CSE Assistant Professor **Murat Demirbas**.

CSEE's Samuel P. Capen Professor Tsu T. Soong, SUNY Distinguished Professor, Retires

CSEE's Professor **Tsu T. Soong**, an internationally recognized authority in the fields of structural dynamics and applied mathematics in engineering, was a co-founder of the NSF supported National Center for Earthquake Engineering Research (NCEER) in 1986, later extended and renamed in 1997 the Multidisciplinary Center for Earthquake Engineering Research (presently called MCEER).

An author of 10 scientific books and monographs, Professor Soong is a pioneer in the field of structural control in civil engineering and a leader in new areas of research, education, and engineering applications. Currently many buildings are equipped with seismic protective systems conceived by Professor Soong. In 1999, he received the American Society of Civil Engineers' (ASCE) annual Norman Medal, given for a "paper that shall be judged worthy of special commendation for its merit as a contribution to engineering science." The award recognized his paper "Structural Control: Past, Present, Future," (*Journal of Engineering Mechanics*, September 1997). He earned the ASCE's 2002 Nathan M. Newmark Medal for outstanding contributions in structural mechanics, and was cited "for his pioneering work, innovations and leadership in the theory and applications of structural control systems in civil infrastructure facilities."

For his exceptional contributions, Soong was named SUNY Distinguished Professor in 2004.

Professor Soong's retirement plans include completing two books; travelling; playing tennis and bridge; enjoying art, literature, music, and woodworking; and spending more time with his wife, Dottie and his family.



Comings and Goings

Peggy Lane and **Cheryl Rance-Thorton** retired from the Engineering School after many years of dedicated service, for which we thank them.



Peggy Lane

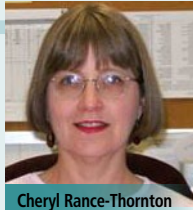

Cheryl Rance-Thorton

Xujun Peng (PhD CSE '05) joined the CSE department as a research assistant after working as a software developer at Copanion Inc. and a researcher and developer at Supresoft.

Obituaries

Pneena Sageev, a dedicated School of Engineering staff member from 1986 to 2007, has passed away. Sageev led the UB Engineering Technical Communications Program, which gained national attention and was cited positively in ABET accreditation visits. Students who benefited from the program often wrote to thank Pneena for their newfound abilities, which boosted their careers.

Before coming to UB Engineering, Pneena was publisher for Battelle Technical Inputs to Planning (B-TIP) in Columbus, Ohio, where she authored the widely acclaimed book, *Helping Researchers Write ... So Managers Can Understand*. The framework of the book was a system she conceptualized called Double 5 – a technical writing equivalent of writing for the scientific method.

Pneena was a wonderful friend, mentor, and teacher, and she will be missed.

UB Engineering mourns the passing of **Willi F. Schulze**, husband of the late Rosel Richter Schulze. Born in Rehsen, Germany, Schulze came to the US in 1966 and in 1968, became the project developer and research engineer for UB Engineering's Electrical and Computer and Engineering department. Willi was also a NYS EMT and enjoyed photography. Together with his son, Martin, he owned and operated Schulze Special Machining and contributed to the opening of Schulze Vineyards and Winery.



CBE's Errington: Molecular Simulation Models Roughness and Wetting Behavior

CBE Associate Professor **Jeff Errington's** group is studying how the microscopic aspects of surfaces influence the macroscopic behaviors of fluids on them, leading to new strategies for designing materials with extremely fine (nanoscale) surface topographies that produce a desired response in contact with a fluid, e.g., designing

ultrahydrophobic (readily water-repellant) surfaces. The research has potential impacts from stain resistance to drag reduction.

Nanoscopically-sized substrate features can significantly affect interfacial properties like wetting behavior, from one of a fluid spreading evenly across an entire surface to one of a liquid beading up into droplets.

The group has developed molecular simulation methods for rigorous and computationally efficient determination of interfacial properties of model systems, notably, measurement of the "contact angle" a fluid droplet forms on a surface. Scientists use this property to infer the ease with which a fluid wets a surface. The larger the contact angle, the less the wetting power. The group's data indicate how the contact angle a droplet forms on a surface evolves with the height of regularly-spaced (nanoscale) hills on a relatively "strong" surface. The results suggest that the spacing between the surface features has a substantial influence on the observed behavior. For large enough spacing between these extremely tiny hills, the evolution of the contact angle can be predicted by a simple and often-used expression introduced by Wenzel in 1936. However, for relatively small spacing (e.g., less than 5 nm), the Wenzel equation significantly overestimates the change in the contact angle with roughness.

From a technological perspective, these results suggest that the use of roughness to influence wetting behavior provides diminishing returns upon reducing the periodicity of the substrate heterogeneity below a critical length scale.

The research is supported by grants from the National Science Foundation and the American Chemical Society Petroleum Research Fund.

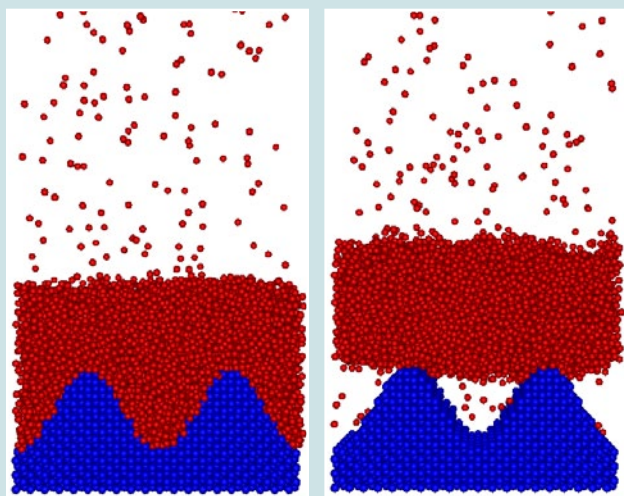

Molecular simulations show examples of the interfacial region between a contoured solid surface (blue atoms) and liquid (red atoms). For strongly interacting surfaces, the fluid fills the grooves; for weak surfaces, the fluid sits atop the asperities.

EE's Litchinitser Developing Metamaterials



EE Assistant Professor **Natalia Litchinitser** directs her group researching metamaterials, to expand fundamental knowledge of light propagation behavior, and present novel solutions to applications from sub-wavelength imaging, to invisibility ("cloaking"), photovoltaic systems, and all-optical signal processing. Metamaterials technology enables new optical materials not found in nature, including negative index materials, near-zero index materials, magnetic positive index materials at optical frequencies, and very complex graded-index structures.

Working with Litchinitser on this project are EE PhD students **Tolanya Gibson** and postdoctoral researcher **Irene Mozjerin**. They recently discovered transition metamaterials, a new class of graded-index metamaterial, whose effective dielectric permittivity and magnetic permeability gradually change from positive to negative values. These materials reveal several peculiar optical phenomena, including anomalous electromagnetic field enhancement and resonant absorption, thus opening new opportunities for linear and especially nonlinear optical applications.

The group's research explores several applications, from low-intensity nonlinear optical devices for wavelength conversion and high-harmonic generation, to optical communication elements integrated with nanoelectronics, and new biomedical sensing applications.

The group also investigates an entirely new regime of nonlinear optical light propagation in directional couplers made of positive and negative index metamaterials. EE PhD Student **Gayatri Venugopal** is participating in this project. Oppositely directed phase and energy velocities in a negative index channel enable such nonlinear optical phenomena as optical bistability, gap solitons, self-oscillations, and novel regimes of modulation instability in these couplers. These effects have no analogies in conventional nonlinear directional couplers with no external feedback mechanism, so new opportunities are present for optical storage and logic applications development.

The research, supported by the United States Army Research Office, is in collaboration with groups from Purdue University and University of Arizona.

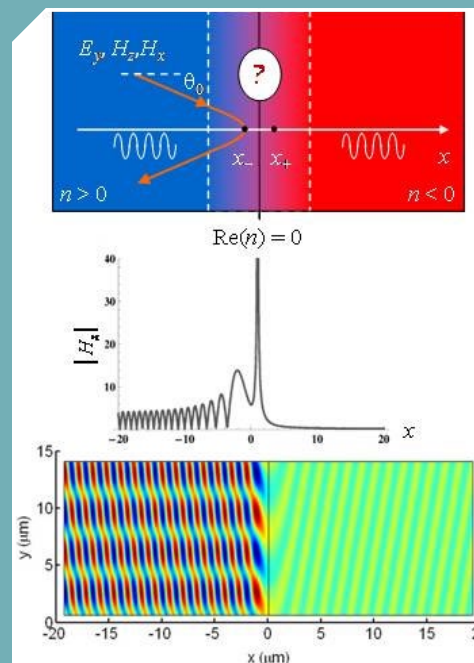

A transition metamaterial layer schematic showing the electromagnetic wave components' distributions with refractive index varying from positive to negative values. The plot in the middle illustrates the effect of strong field enhancement at zero-index transition.



CSEE's Atkinson on Modeling Resource Sheds

CSEE Professor **Joe Atkinson**, Environmental Fluid Mechanics Laboratory Director and Great Lakes Program Director, is researching new methods for determining source areas for surface waters and entrained materials.

Together with US Environmental Protection Agency (EPA) Ecologist David Raikow, and National Oceanic and Atmospheric Administration (NOAA) Great Lakes Environmental Research Lab Research Hydrologist Tom Croley, he has published research on these new methods.

The group has been working on modeling resource sheds, or source areas supplying materials to downstream locations in lake environments. To clean up coastal ecosystems like the Great Lakes, the sources of pollution must be determined. The group's new methods are described in two recent papers: "Development of Resource Shed Delineation in Aquatic Ecosystems," (in *Environmental Science & Technology*, 2010, DOI: [10.1021/es900562t](https://doi.org/10.1021/es900562t)); and "Hydrological Resource Sheds," (published with C. He, in the *Journal of Hydrologic Engineering*, 2008, DOI: [10.1061/\(ASCE\)1084-0699\(2008\)13:9\(873\)](https://doi.org/10.1061/(ASCE)1084-0699(2008)13:9(873))).

Water flow acts as a physically forcing variable that moves materials within and between ecosystems. Environmental issues of high management priority in aquatic ecosystems occur over vast geographic scales, crossing multiple ecosystem boundaries. Analysis, explanation, prediction, and management of ecological phenomena must account for flow, *i.e.*, spatial and temporal patterns of material supply, in aquatic ecosystems. A resource shed is the geographic area defining where mobile materials (*e.g.*, pollutants, sediments, suspended nutrients) supplied to a specified location originated.

Resource shed analysis has many applications, including study of harmful algal bloom formation; study of the physical drivers of fish production; and both forensic offshore and inland non-point contaminant source identification.

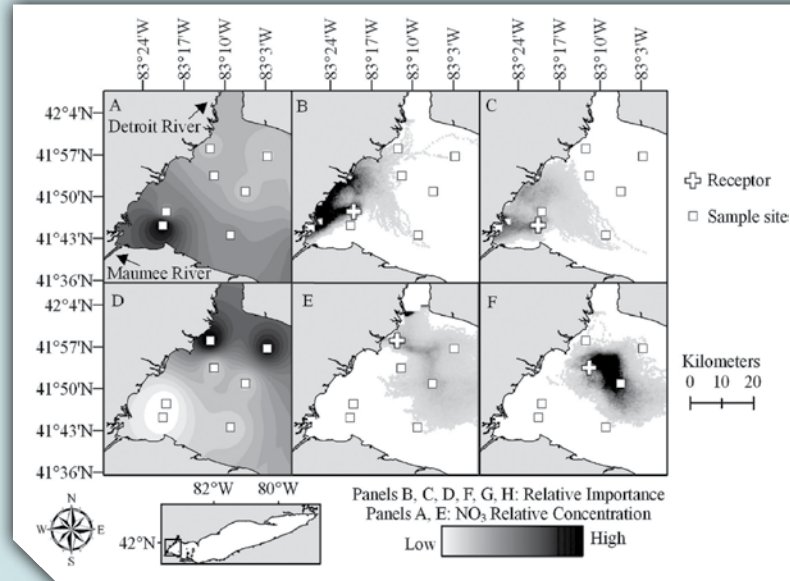

Model validation tests. (A) Spatial distribution of epilimnetic nitrate (NO₃) relative concentration in May of 2005. (B) 1-week type 3 resource shed for site 973 in May 2005. (C) 1-week type 3 resource shed for site 835 in May 2005. (D) Spatial distribution of epilimnetic nitrate (NO₃) relative concentration in August of 2005. (E) 1-week type 3 resource shed for site 881 in August 2005. (F) 1-week type 3 resource shed for site EPA60 in August 2005.

CSEE Researchers Contribute to World's Largest Earthquake-Safe Building

At over two-million square feet, the new international terminal at Istanbul's Sabiha Gökçen Airport is the world's largest seismically isolated building. Key background work on building and designing the structure was done by three researchers affiliated with UB Engineering. CSEE Professor **Michael Constantinou** did the peer review for this structure, checking the work of the engineer for owner-approval, to proceed with commissioning of the facility, and Professor **Andrew Whittaker** was a consultant for the engineering firm, Arup. Basic developments in understanding and modeling the behavior of the seismic isolation system for this structure were done at UB Engineering by **Daniel Fenz** (BS '03 MS '05 PhD '08 CSEE), now with ExxonMobil. The terminal is designed to withstand an earthquake as strong as 8.0.

Istanbul, located near the confluence of the Arabian, African, and Eurasian plates and less than 15 miles North of the North Anatolian Fault, may suffer a large quake within the next 30 years, according to scientists.

The terminal rests on over 300 isolators which can move side-to-side during an earthquake, allowing the building to move as a single unit. This prevents damage from uneven forces acting on it, so that it will withstand only one-fifth of the acceleration than it otherwise would have incurred without the earthquake proofing.

Constantinou said the Istanbul project is similar to quake-proofing done at the San Francisco Airport's international terminal, one of the first projects to use this advancement, but the terminal at the Istanbul airport uses newer, more compact and affordable seismic isolation devices called triple friction pendulum isolators.

The work was recently reported in *Wired.com*.

(Right) The new terminal in Istanbul

(Below) The triple pendulum slider; Isolators slow down the motion of the building. Photos: ARUP

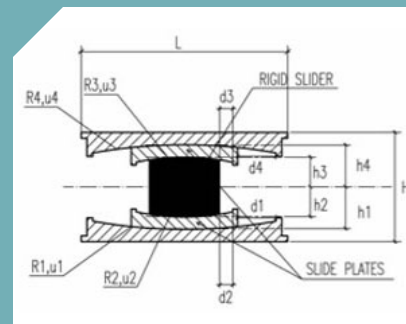

CBE's Swihart Group Researches Silicon Quantum Dots for *In Vivo* Applications

The group led by CBE Professor Mark Swihart, Director, Integrated Nanostructured Systems, is working on research involving applications of silicon quantum dots, together with the Institute for Lasers, Photonics and Biophotonics (ILPB), and the Chemistry department.

Quantum dots (QDs) have size-dependent optical properties that make them uniquely advantageous for *in vivo* targeted fluorescence imaging, traceable delivery, and therapy. The use of group II–VI (e.g., CdSe) QDs for these applications is advancing rapidly, yet these contain toxic heavy metals that limit their *in vivo* applications. Thus, replacing these with QDs of a biocompatible semiconductor, such as silicon (Si), is desirable.

The group's research demonstrates that properly encapsulated biocompatible Si QDs can be used in multiple cancer-related *in vivo* applications, including tumor vasculature targeting, sentinel lymph node mapping, and multi-color NIR imaging in live mice. This work overcomes previously insurmountable challenges to *in vivo* imaging with Si QDs through a unique nanoparticle synthesis, surface functionalization, PEGylated micelle encapsulation, and bioconjugation process that produces bright, targeted nanospheres with stable luminescence and long circulation time (over 40 hours) *in vivo*.

Si QDs can play an important role in more sophisticated *in vivo* models, by alleviating QD

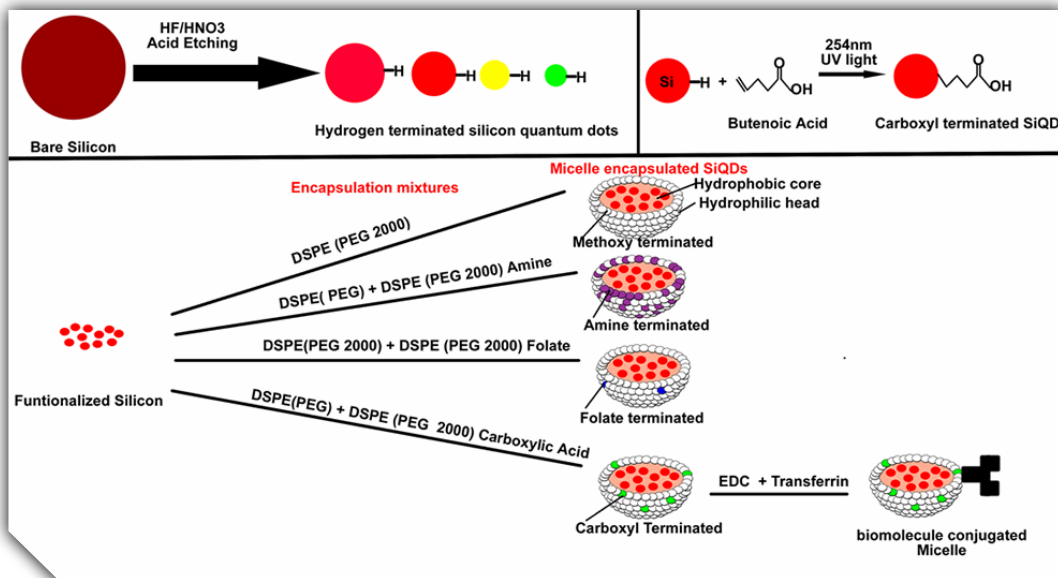

Scheme 1. Synthesis and surface functionalization of Si quantum dots.

toxicity concerns, while maintaining the key advantages of QD-based imaging methods.

Funding for this study came from NSF IGERT, the John R. Oishei Foundation, the UB Gerald Sterbutzel Fund, and the UB Interdisciplinary Research and Creative Activities Fund. Working with Swihart are Chemistry Distinguished Professor and Capen Chair, ILPB Director

Paras N. Prasad (with appointments in EE, Medicine, and Physics); Research Assistant Professor Indrajit Roy and Senior Research Specialist Rui Hu; ILPB Postdoctoral Associates Hong Ding, Folarin Erogbogbo (PhD CBE '09), and Ken-Tye Yong (PhD CBE '06); Microbiology and Immunology Postdoctoral Associate Weiwei Zhao; and EE PhD student Wing-Cheung Law.

CSE's Zhong: INPAC Encourages Cooperation in Wireless Networks

CSE Assistant Professor Sheng Zhong looks at resolving problems associated with wireless mesh networks (WMN), which have been widely deployed to provide broadband network access.

The WMN performance can be significantly improved by using a new technology called network coding. However, this new technology also introduces a new problem: in a WMN using this network coding, devices belonging to selfish users may deviate from the protocol when they are supposed to transmit data originating from other devices.

This is a fundamental problem because if devices don't transmit the intended data, the entire network can go down. In his research, Zhong proposes a novel solution to this problem called INPAC.

By using a combination of advanced techniques from game theory and cryptography, INPAC guarantees cooperation in the network. Zhong has fully implemented and evaluated INPAC on a testbed, with results demonstrating the strengths of the solution.

The research is part of Zhong's NSF CAREER project, and the findings appear as "INPAC: An Enforceable Incentive Scheme for Wireless Networks using Network Coding," in *INFOCOM 2010, Proceedings of the 29th IEEE International Conference on Computer Communications*, with CSE PhD student Tingting Chen as co-author, a Zhong advisee.

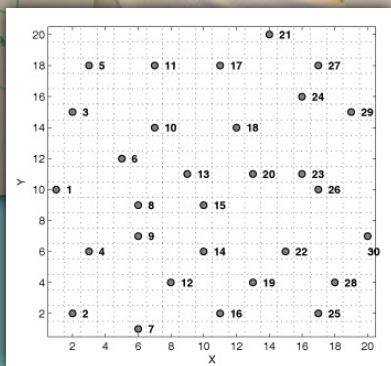
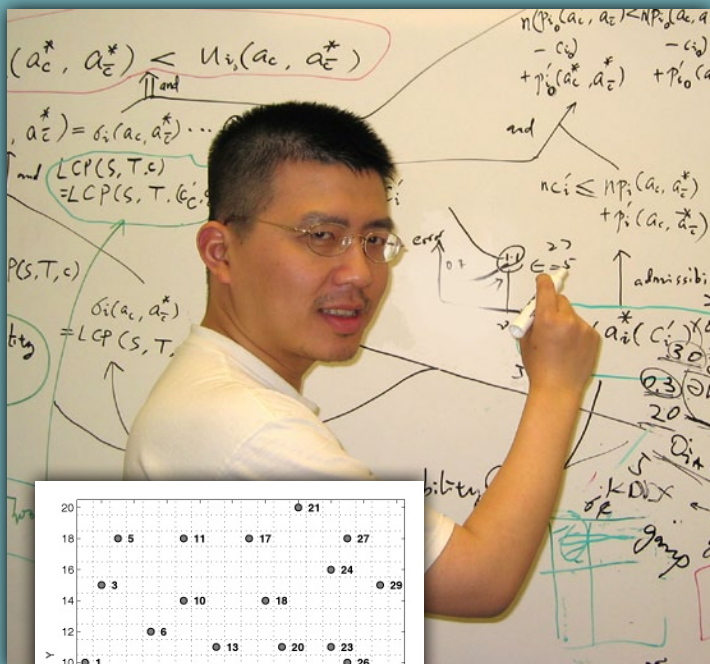

The testbed topology

CSEE's Mosqueda Tests Building Collapse with Innovative Model



CSEE Assistant Professor **Gilberto Mosqueda** is principal investigator on a research team from UB and Kyoto University, Japan, which has successfully innovated a hybrid approach to test buildings for their ability to withstand full-scale earthquakes. The safer, less expensive technique simulates quakes in a lab, rendering shake-table testing, in some cases, unnecessary. The new approach helps researchers better understand “how much damage structures can sustain before collapsing so people can safely evacuate,” according to Mosqueda, and “how to improve new construction or retrofit existing buildings so that they are less likely to collapse.” CSEE doctoral student **Maria Cortes-Delgado** participated in the research.

The two-hour “slow motion earthquake” test subjected the hybrid model to ground motions representing approximately the first five seconds of the 1995 Kobe, Japan quake. Instead of using a full-scale steel building, the researchers developed a hybrid representation of an earlier, full-scale test by combining experimental techniques carried out in earthquake engineering labs in Buffalo and Kyoto, with numerical simulations conducted over the web. Only the parts of the buildings that were expected to initiate collapse were tested experimentally, so that the shake tables were not subjected to the stress and of an enormous load that can crash down on the equipment. Mosqueda explained, “You can’t allow a structure to collapse completely on a shake table. You need to have support mechanisms in

(Right) Local buckling at top and bottom of center column leading to collapse mechanism

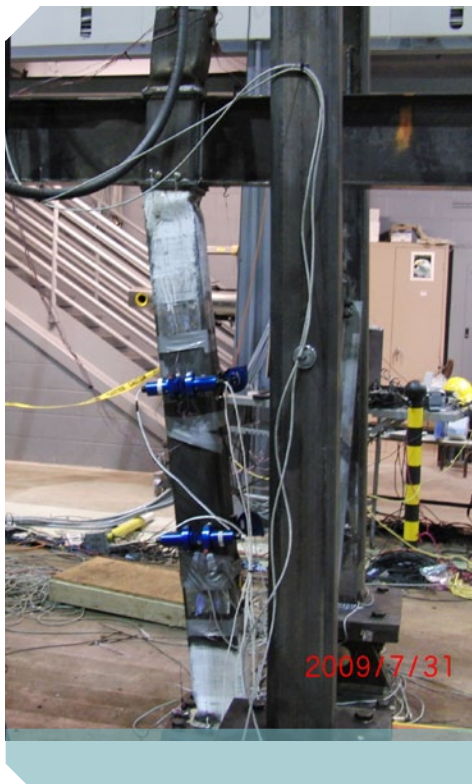

place, like scaffolds, to catch the falling structure.”

“In this case, we simulated the load with high-performance hydraulic actuators so the specimen overall was actually pretty light,” explains Mosqueda. “Here, we just shut off the hydraulics and the load disappeared.”

The research is part of Mosqueda’s NSF CAREER research award program.

As this issue was closing, Mosqueda visited Chile to learn about the damage sustained to hospitals, tall, engineered buildings, and their nonstructural components during that country’s recent very powerful earthquake and its aftershocks. Mosqueda was part of a national team organized by the Earthquake Engineering Research Institute. Two UB Engineering alums were also on the mission: University of Nevada, Reno Assistant Professor **Gokhan Pekcan** (MS ’94 PhD ’98 CIE) and **Rodrigo Retamales** (PhD CIE ’08), a professional engineer in Chile.

NEES@Buffalo Recognized for Outstanding Service

NEES@Buffalo received an Outstanding Service to Researchers Honorable Mention Award for exceptional support on the NEES Grand Challenge entitled “Seismic Risk Mitigation for Port Systems.” The award, given to a NEES site in recognition of research support services that greatly exceeded expectations, was presented at the NEES Annual Meeting. The UB team was nominated for its outstanding support of the experimental portion of the seismic performance of cranes project.

CSEE's Sadek Helps Design Traffic Text Alert System

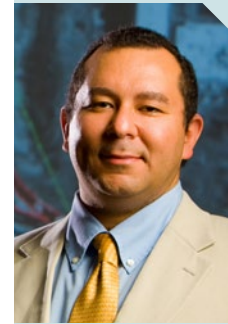

A free subscription traffic alert system has been designed with the help of CSEE Associate Professor, Transportation Systems Laboratory (TSL) Director **Adel Sadek** and CSEE PhD student and TSL researcher **Shan Huang**. The system allows area drivers in Western New York (WNY)

and Southern Ontario, Canada to receive text or e-mail traffic warnings.

The team collaborated with the Niagara International Transportation Technology Coalition (NITTEC), which collects comprehensive traffic data through its surveillance network. Sadek and Huang developed an algorithm to search through the traffic data, sort it, and distribute it to subscribers.

A MY NITTEC subscriber enters her daily travel times and routes at <http://mynittec.org/> to receive alerts about major incidents (not recurring traffic issues).

CSEE's Filiatrault Leads United Nations-Appointed Post-Quake Assessment Team in Haiti

continued from page 3

INSPECTED (Green) – Appears safe for lawful occupancy; LIMITED ENTRY/RESTRICTED USE (Yellow) – Limited entry/use, controlled by building owner/manager; UNSAFE (Red) – No entry unless controlled by jurisdiction. While many structures were unsound, Filiatrault described the population’s fear of entering even those buildings that the team deemed safe for re-entry (see cover image). For example, several empty hospitals were judged functional, yet patients were being treated outdoors, and almost all of the Port-au-Prince population slept in tents or directly outside. Filiatrault expressed concern that a lack of understanding of earthquakes there compounded the hardship caused by the disaster.

Of MCEER’s numerous reconnaissance missions since its inception in 1986, this was its first direct relief mission; MCEER’s primary focus is conducting multidisciplinary, multi-hazard research and education. The mission’s sole purpose was humanitarian, said Filiatrault, “to ensure the safety and welfare of Haitian citizens,” by applying earthquake engineers’ knowledge when it is most urgently needed.

ISE Research for US Office of Naval Research and Air Force Research Lab

Continuing the ISE department's history of researching vehicle routing and logistics are ISE's Professors **Mark Karwan** (PI), **Rajan Batta** (Associate Dean for Graduate Studies), **Rakesh Nagi** (ISE Chair), and **Moises Sudit** (Research Professor). MAE Professor **John Crassidis** is also part of the team working on an ongoing three-year Office of Naval Research-funded (ONR) project that focuses on the coordinated routing of airborne platforms. The program, Optimization Planning and Tactical Intelligent Management of Aerial Sensors (OPTIMAS), develops advanced decision aids to assist military operators in optimally deploying sensor assets in real-time. It facilitates automated planning for courses of action (COA) at the strategic and tactical levels to counter suspected threats and achieve decision superiority, with a focus on Unmanned Aerial Vehicles (UAVs) at multiple levels of detail.

The ONR research investigates problems including coordinated surveillance of a fleet of unmanned aerial vehicles (UAVs) on a large number of predetermined targets, and reaction to changes in the battle space with the awareness of new targets and/or loss of platforms or carried sensor capability. The accompanying schematic illustrates a typical decision sequence.

The research is also funded by the Air Force Research Laboratory (AFRL) and corporate partners, and much

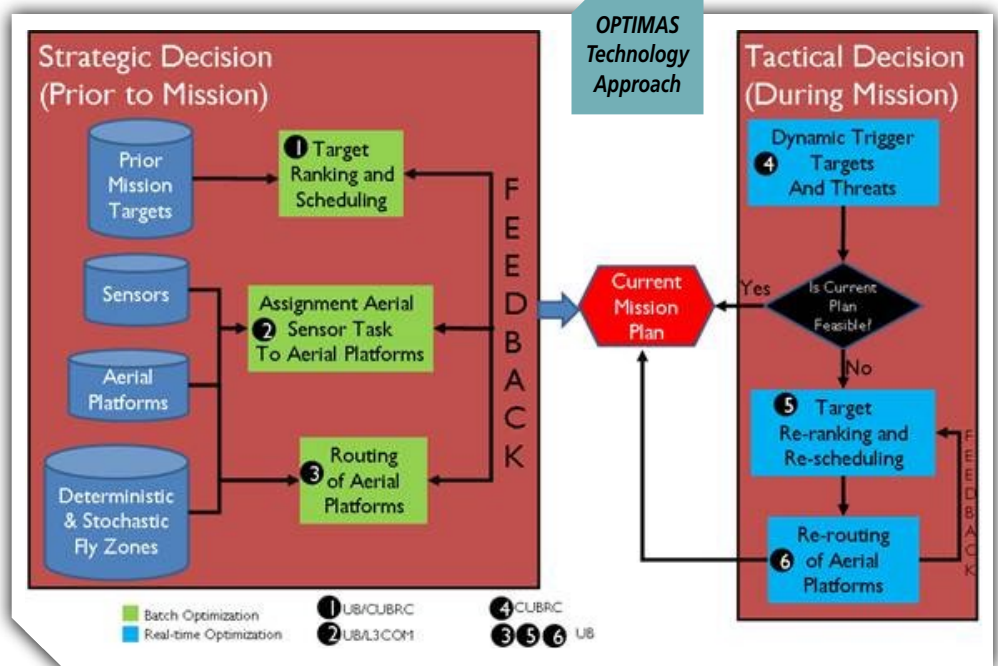

of the work has been done through the Center for Multisource Information Fusion (CMIF) and CUBRC (Buffalo, NY).

The AFRL work considers a more general "dynamic resource allocation" or "course of action" paradigm

for a mix of manned and/or unmanned airborne vehicles in either a surveillance or strike mission.

The ONR and ARFL projects are currently supporting six PhD students who are making invaluable contributions to the research.

MAE's Ringuette in Hummingbird's Vortex

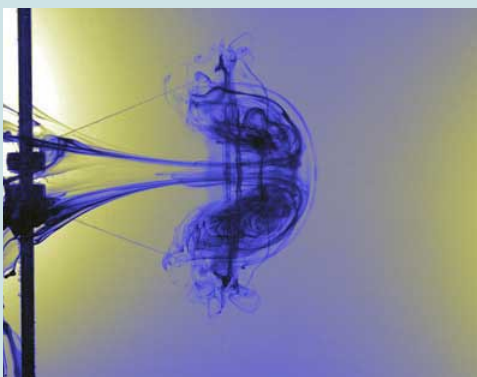

MAE Assistant Professor **Matthew Ringuette** is researching the three-dimensional, vortex-formation process caused by a hummingbird's flight, for intelligence applications in challenging environments – remote caves or complex building corridors – places that conventional, unmanned aircraft or spy satellites can not penetrate.

The research is funded by the Air Force Office of Scientific Research (AFOSR) Young Investigator Research Program. Ringuette is one of 38 young

scientists nationwide to receive the award.

The propulsion systems of tiny birds and insects may hold the key to designing small, bio-inspired micro-air surveillance vehicles, because at "such small sizes and slow speeds, conventional aerodynamics no longer apply," Ringuette explains.

Instead of the streamlined flow of air over jet wings, for example, the fluid dynamics of flapping hummingbird wings are characterized by swirling flows and vortex formations, similar to those

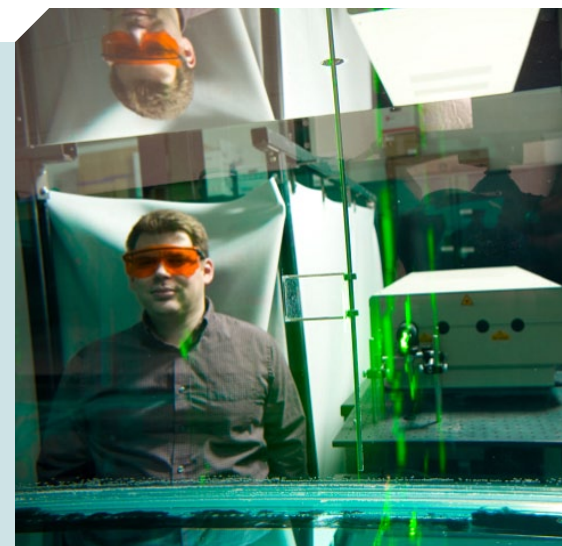

created by canoe paddles pushed through water.

Small animals "take advantage of this vortex formation to achieve flight and outstanding maneuverability," says Ringuette.

Ringuette is researching how the vortex growth and development scales with wing motion, shape, and size, to optimize a micro-air vehicle's wing efficiency and propulsive force. This work is also fundamental to three-dimensional vortex formation in general, found in cardiovascular flows and wind-energy applications.

Protean Software by MAE's Kesavadas and Tactus Team



MAE Professor **Thenkurussi ("Kesh") Kesavadas**, UB Virtual Reality Lab (UBVRL) Director and a Tactus Technologies co-founder, worked with a team to develop Protean, a new 3-D virtual clay sculpting software package that speeds computational design of complex, organic shapes like the human form.

Tactus Technologies is a UB technology spinoff company started by UB researchers who developed some of Protean's technologies. Tactus President and Chief Scientist **Kevin P. Chugh** (PhD MAE '01) explained that the software will be a boon

"real-time, 3-D volumetric modeling without requiring a lot of computing power,"

to many, including artists and industrial designers and engineers, because it allows "real-time, 3-D volumetric modeling without requiring a lot of computing power," making it an enormous technological advancement.

Kesavadas adds that Protean can design organic forms like the human head in fewer steps and far more intuitively than other software. Protean is also unique in that each design the user develops can be added to the tool palette, so that designs themselves become tools or building blocks. Users also can use an image to create or emboss a 3-D texture on a sculpted object's surface.

Kesavadas and UBVRL researchers are leaders in haptic technologies development – those that bring a sense of touch to virtual reality. They are developing advanced VR applications for medical, surgical, and educational applications.

Kesavadas notes that MAE's UBVRL is one of just a handful of US research centers focused on the design and the manufacture of VR applications; at UBVRL, both software and hardware are built.

Two 3-D sculpted models created using Protean software

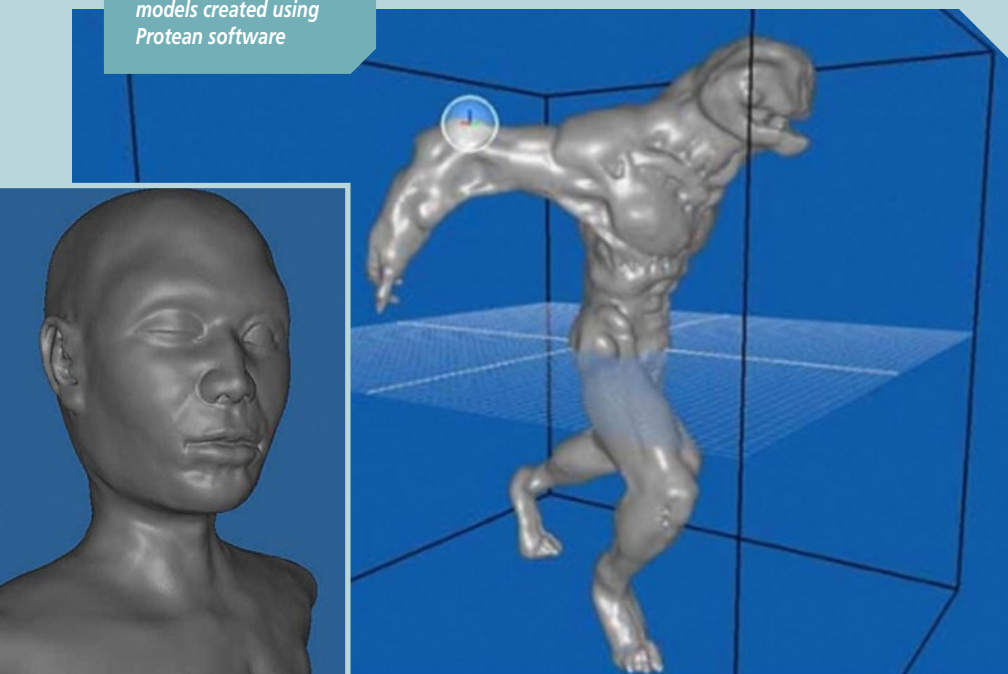

ISE's Wu on Safety of Phone Use While Driving



ISE Assistant Professor **Changxu Wu** co-authored research revealing that some young drivers are unaware that neither hands-free nor handset cell phones are safe to use while driving, but this message isn't reaching many of them, and should be taught in driver education.

Nearly half of the 164 student drivers studied (ages 18–35) assumed that hands-free phones were safer than handheld models. The males studied perceived about 20 percent less risk with hands-free phone use than females, so Wu says young men may require more instruction on the issue.

While the study looked at students attending driver education in Beijing, China, its findings may be applicable to drivers in other regions, including the US, because brain wave function is taxed when performing two different tasks at once. If the brain perceives a high workload, Wu explains, it will delay processing certain messages to manage the workload, causing drivers to get distracted. Dialing while driving causes a higher mental workload, and driving while texting will produce an even higher and more distracting workload, says Wu.

The research, funded by the China Postdoctoral Science Foundation and the National Natural Science Foundation of China, was published in *Transportation Research Part F: Traffic Psychology and Behaviour* (2009). Co-authors are Ronggang Zhou, Beijing University of Aeronautics and Astronautics, and Pei-Luen Patrick Rau and Wei Zhang of Beijing's Tsinghua University.



NAE Member and First DAC Chair Bloch Supports Engineering Scholarship



Erich Bloch

Distinguished alumnus, National Academy of Engineering member, and 1985 National Medal of Technology winner **Erich Bloch** (BS EE '52, Hon.ScD '85) has given a substantial gift to fund scholarships for undergraduate engineering students.

His extraordinary gift will fund two groups of scholars: the Erich Bloch Engineering Dean's Scholars, and the Erich Bloch Scholars.

Bloch, a long-time UB Engineering benefactor, has given both philanthropically and personally to the school. From 1995–97, he was the first chair of the Dean's Advisory Council (DAC), working with then-Dean Karwan to recruit distinguished members and establish a meaningful agenda for the Council. He was conferred the title of DAC Chair Emeritus upon leaving. Bloch received the 2000 UB Engineering Dean's Award. His generosity has benefitted many students through his gifts to UB Engineering's Rachel Rosen Scholarship series, initiated in 1999 and continuing.

Bloch serves on the Council on Competitiveness, which he joined as its first distinguished fellow in 1991, and he is a Principal of the Washington Advisory Group, LLC. His notable career includes 32 years of service to IBM Corporation, where he pioneered the development of the revolutionary IBM/360 computer and later became an IBM Vice President. He continued on to an appointment as National Science Foundation director from 1984–90.

He has earned many awards; of his eleven honorary degrees from American universities, the State University of New York bestowed his Honorary Science Doctorate in 1985. He received the UB Alumni Association's 1996 Clifford C. Furnas Memorial Award for distinguished achievements in science and engineering, and its most prestigious honor, the 2004 Samuel P. Capen Award, for meritorious contributions in support of the university.

Patrick P. Lee Foundation Gift to Aid in Establishing Engineering North



Presentation of gift (L to R): Chris Lee, son of Patrick P. Lee; UB's Althea Luehrsen, Assistant Vice President of Corporate and Foundation Relations; Michelle Lee, wife of Chris Lee; and Frederic Cook, Patrick P. Lee Foundation Executive Director

Motion Control (IMC) was formed and grew to become a worldwide conglomerate.

Patrick P. Lee formed the foundation in 2005 as a charitable organization dedicated to promoting awareness through education and research, which seeks to align itself with organizations sharing the same passion.

Patrick Lee supports the Buffalo, NY community by serving on various boards and making many generous charitable contributions to local organizations including the Roswell Park Cancer Institute. Lee was Roswell's first chairman of the board after it became a public-benefit corporation.

In 2007, Patrick Lee sold IMC to the ITT Corporation, allowing the Patrick P. Lee Foundation to grow. Patrick P. Lee is Chairman; serving as directors are his wife Cynthia R. Lee; and his adult children: Patrick W. Lee; Christopher J. Lee; Jennifer Lee McNamara; and Barbara Rhee.

UB Engineering received a generous gift from The Patrick P. Lee Foundation, which will help establish the School of Engineering's new building, Engineering North. In honor of the gift, a lab will be designated in the Lee Family Foundation name.

The Patrick P. Lee Foundation was formed by Patrick P. Lee, an inventor and engineer who founded the Buffalo, New York-based Enidine Incorporated, a premier manufacturer of shock absorption and vibration isolation products. As other product lines were acquired, a holding company, International

Smists Fund Scholarship to Honor Father, Felix

James Smist (BS CE '80) and his wife Mary have donated generously to support an engineering student studying under similar circumstances as Jim's late father, **Felix Smist** (BS ME '65), who persevered to complete his ME engineering degree after 16 years of part-time study. Felix Smist did so while working full time and raising a family, completing his ME bachelors in 1965.



Felix Smist

The scholarship honors Felix Smist by funding a part-time engineering student's full tuition for up to six years, in order to make educational goals a reality for those in situations like Mr. Smist's.

Felix Smist's commitment to higher education has been an enduring example to his son Jim, of McLean, Virginia, who credited his own engineering education for imbuing "the systematic thinking process and quantitative capabilities" that have been a "continuous use" to him. Jim is president of Dean & Company, a national and international corporate management consulting firm. He was five years old when he attended his father's graduation from UB.

Jim and Mary Smist hope that the gift will benefit the school while encouraging students and honoring the memory of Felix Smist's dedication to the pursuit of higher education.

Gifts to New Building: Future Home of CSE and EE Departments

Michael and Mary Salvadore Gift

The Salvadores, of Clarence, NY, have given a gift to name a space in Engineering North.

Michael Salvadore (BS CIE '82) leads CATCO contracting company. Established in 1995, the company's main enterprise is road construction and repair. Mary Salvadore is owner of Marage Trucking, Inc.

Salvadore is a member of The Crisis Program, a coalition whose mission is to communicate roadway improvement situations to the state. He is also a member of the NY State Society of Professional Engineers' Erie-Niagara chapter, which awarded him the recognition of Engineering Manager of the Year.

Anna Marie and Ephrahim Garcia Gift

Cornell University MAE Professor Ephrahim Garcia (BS '85, MS '88, PhD '90 AE) and his wife **Anna Marie Garcia, MD**, have also pledged a gift to the school's new building.

Garcia is a Dean's Advisory Council member who has avidly supported the school over the years in his capacity as an advisor and as a distinguished alumnus.

Anna Marie Garcia is a medical doctor in obstetrics and gynecology. Ephrahim heads Cornell's Laboratory for Intelligent Machine Systems. Previously, he was a program manager at the Defense Advanced Research Projects Agency and an associate professor at Vanderbilt University. Of his many fellowships and awards, he earned the American Society of Mechanical Engineers' 2003 Adaptive Structures Prize; was appointed a Presidential Faculty Fellow by President Clinton; was named an Office of Naval Research Young Investigator; and held a NASA graduate student fellowship. He received the UB Alumni Association's 2000 George W. Thorn Award, which recognizes alums under 40 for outstanding national or international contributions to their field.



(Above) Michael and Mary Salvadore



(Right) Ephrahim Garcia

Garmans: Continuing Generosity to School

Patricia (MS Nursing '79 UB) and **Richard Garman** (BS CIE '56 Bucknell University), ongoing and generous supporters of the University at Buffalo and the School of Engineering, recently pledged a continuation of their support of the Engineering School's endeavors. The Garmans' past gifts to the school have funded Richard E. Garman Endowment CSEE scholarships.



Patricia and Richard Garman

Richard Garman, former president and CEO of Buffalo Crushed Stone, Inc., has served on several boards and held top-level positions including president of R & P Oak Hill, LLC (real estate), and Newbery Alaska Inc. (electrical contracting). Patricia Garman is former president of Counseling Specialists, a private psychiatric nursing practice, and a founder of Compeer West, an organization that assists those struggling with mental health concerns. She is also a former nursing instructor at D'Youville College.

The couple was awarded the Alumni Association's 2007 Dr. Philip B. Wels Award in recognition of their achievements enhancing the UB community's quality of life.

THANK YOU, DONORS

We thank our donors for their generosity.

Please visit:

<http://www.eng.buffalo.edu/alumniFriendsDonors/donors/> and the sidebar links to learn more about recent gifts and giving.

We are pleased to say that the UB Engineering Annual Fund has enjoyed steady growth in the past few years.

Your financial support is critical to the mission of the School.

If you're energized by UB Engineering's excellence, and wish to participate in the School's dynamic and continued growth, please consider a gift to the School.

To make a contribution, please visit http://www.eng.buffalo.edu/alumni_friends_donors.php and click on "Donate" in the left sidebar.

Development staff can be contacted any time at 1.888.205.2609 or directly, below:

- **Tim Siderakis**, Asst. Dean & Sr. Director: tsiderak@buffalo.edu, 716.645.0970
- **Michael Madonia**, Director: mmadonia@buffalo.edu, 716.645.0969
- **Jenine Trzewieczynski**, Asst. Director: jt87@buffalo.edu, 716.645.0968
- **Donna Linenfelser**, Development Associate: dfelser@buffalo.edu, 716.645.0997



Development staff (l to r): Tim Siderakis, Donna Linenfelser, Michael Madonia, and Jenine Trzewieczynski

Again, we thank all of our donors for their generosity.

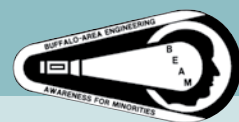

BEAM TREK 2010: The Adventure to Go Green

Buffalo-area Engineering Awareness for Minorities (BEAM) is a nationally recognized program promoting educational excellence and equality that earned the 2008 US Department of Labor's EPIC award. BEAM's upcoming BEAM TREK 2010 will be an educational engineering competition with a focus on alternative energy sources, the winning team of which will be dubbed Buffalo's Best Green Engineering Team of the Future.



Participants in last year's BEAM Trek

For those interested in supporting BEAM TREK 2010 and its overall themes of diversity and environmentally friendly technology for a greener future, sponsorship opportunities are available at any level. BEAM TREK helps students learn the values of planning, listening, and teamwork during a daylong competition and post-competition networking social for students, parents, UB faculty, sponsors, and volunteers.

BEAM is a non-profit, cooperative educational enrichment program that prepares under-represented school-age children and teens for technical careers by providing math, and science and engineering experiences through its clubs, summer programs, internships, and other related activities. BEAM's success is measured by student participation in BEAM programs, college completion in a technical discipline, and eventual employment.

BEAM was founded in 1982 by a consortium that included UB Engineering, Linde-Union Carbide (now Praxair, Inc.), Omega Phi Phi Fraternity and the Buffalo Public Schools. Funding is made possible through the generous support of companies, educational institutions, community organizations and individuals. For more information about BEAM, please visit <http://www.eng.buffalo.edu/beam>.

BEAM Events: Senior Dinner and Annual Breakfast



Dean Stenger with BEAM award

BEAM's annual Senior Dinner, organized on the theme "Preparing Our Children for the Challenges of the 21st Century," was sponsored by DuPont and the School of Engineering, with table sponsors: Association of Facilities Engineering; Buffalo Public Schools – Career & Technical Education; Cannon Design; Fisher-Price; General Motors; Powertrain – Tonawanda Engine; LP Ciminelli; MOOG, Inc.; Praxair; and R & P Oak Hill.

Senior Scholarship awards from BEAM, DuPont, Fisher-Price, Turner, and Wendel Duchscherer were awarded to the following BEAM students: Marcus Alexander, Raven P. Baxter, Malcolm C. Bernard, Erica M. Bliss, Ivilesse Borges, Ashley Brown, Denzel X. Cottrell, Shamice Ellington, Dabwan M. Hassan, Bria S. Johnson, Denzel D. Moore, Elijah Noble, Laurence Oaks, Andrew F. Osei, Carl Reeves, Jade Robinson, Taylor Travis, Abdulrahman Umar, and Justin Zimpher.

More recently, the BEAM Annual Breakfast recognized the following UB Engineering faculty and BEAM supporters with honors:

- Charles Campbell Sr. Outstanding Service Award: Dean Harvey G. Stenger Jr.
- Corporate Partner of the Year Award: National Grid, received by Dean's Advisory Council Chair Dennis Elsenbeck (ME MEng '96)
- Faculty Advisor Award: received by AE student Ron Heichman, President; and ME student Carl Javier, Vice President, Society of Hispanic Engineers, student chapter
- Special Achievement Award: EE Assistant Professor *Jennifer Zirnheld (BS '93 MS '97 PhD '04 EE)
- Technical Advisor Award: Uyi Iyoha, Praxair
- Tony Campagna Memorial Award: Tyra Johnson, LP Ciminelli

NYSCEDII's Annual Cyber Engineering Workshop for Young Women

The New York State Center for Engineering Design and Industrial Innovation's (NYSCEDII) annual Cyber Engineering Workshop for Young Women, now entering its tenth year, introduces young high-school women to the possibility of pursuing engineering careers through hands-on experience with engineering design from concept to virtual prototype creation.

NYSCEDII Deputy Director **Ken English** explained that the workshop series actively challenges young women with design exercises, demonstrating that "engineering is about developing an understanding of how decisions will impact a product's design." The program covers topics from computer graphics and motion control to virtual prototyping, offerings not available at most high schools.



Assisting in last year's program were two workshops alums – ME undergrad **Nichaela Bald** and Meagan Swartz (North Tonawanda High School) – with professional Fisher-Price engineers as mentors. The program is guided by NYSCEDII research scientists and staff, and MAE and ISE students. Last year's workshop sponsors were Fisher-Price, General Mills, Lockheed Martin and Praxair.

For application materials and more information on this summer's workshop program, please visit <http://www.buffalo.edu/nyscedii>. (Applications are due by April 30, 2010.)



Participants in last year's Tech Savvy event

Tech Savvy Five

The American Association of University Women (AAUW) Buffalo branch recently held its fifth annual Tech Savvy conference on UB's Amherst Campus. Tech Savvy inspires middle-school girls to pursue careers in science, engineering, technology, and math through fun workshops, with topics for parents, teachers, and adults as well. Fair-pay activist Lilly Ledbetter opened this year's adult session. The conference is made possible with support from AAUW, the Praxair Foundation, the School of Engineering, the University at Buffalo, and WTS, Inc.

1960s

Alan Kasper, BS EE '64, was named President of the American Intellectual Property Law Association (AIPLA), a leading law association of patent, trademark, and copyright lawyers. Kasper is a senior partner at Sughrue Mion PLLC, an international intellectual property firm.

1970s



Steve Amos

Steve Amos, BS ME '78, is a consultant and product manager. He was recently included in *Adapt! How to Survive and Thrive in the Changing World of Work* (Solutions Press, 2009).



Robert H. Fritzinger

Robert H. Fritzinger, BS CS '76, is Director, SUNY Fredonia's Business Technology Incubator (BTI) in Dunkirk, NY. Fritzinger is affiliated with the Panel of Advisers for the Science and Technology Law Center, part of the Albany

Law School Center for Law & Innovation. He has also served as an advisor to UB's Center for Entrepreneurial Leadership. Fritzinger master's in counseling psychology is from UB.



Dennis M. Kelleher

Dennis M. Kelleher, BS CIE '78, P.E., was elected the 2010 Director of American Water Works Association's NY Section. He is H2M's Water Resources Senior Vice President and Director.

Donald W. Lake, Jr., BS CIE '70, PE, CPESC, CPSWQ, is Technical Coordinator and Principal Instructor at SUNY's College of Environmental Service and Forestry (ESF), Syracuse, NY. Lake served in the USDA Natural Resource Conservation Service for 27 years and is an adjunct faculty member at ESF. He is conducting the Central NY Planning and Development Board's Stormwater Management Training Series this year.

***Gary A. Peck**, BS '68, MS '72 CE, has been appointed an associate of Ronald J. O'Mara, a Williamsville engineering consulting firm.



Daniel Phillips

Daniel Phillips, BS EE '79, is an EE Associate Professor at Rochester Institute of Technology. He is an expert in systems design, embedded software, and communications and biomedical engineering.

1980s



Joel M. Bach

Joel M. Bach, BSAE '87, is an Associate Professor at the Colorado School of Mines' Engineering Division, and an Associate Clinical Professor at the University of Colorado's Orthopaedics Department's Orthopaedic Biomechanics Labs.

Captain Antonio Edmonds, BS IE '87, is a decorated Navy Seabee Combat War Officer. He was featured on the cover of the US Navy Memorial and Navy Heritage Center pamphlets, for the center's celebration of the Year of the Seabees and Civil Engineers Corps. His master's degrees are in EnvEng and national security and strategic studies.



Jonathan J. Hull

Jonathan J. Hull, BS '80 MS '82 PhD '87 CS, is now Ricoh Innovations, Inc.'s Manager of Multimedia Document Analysis at their California Research Center. He had been Ricoh's Research Team Leader since 1994. Prior

to Ricoh, he was a Research Assistant Professor and Research Associate Professor in UB's CS department, and was Associate Director of the Center of Excellence for Document Analysis and Recognition (CEDAR).



Yogendra Joshi

Yogendra Joshi, MS ME '81, is McKenney/Shiver Distinguished Chair and Associate Chair for Graduate Studies at Georgia Institute of Technology's GW Woodruff School for Mechanical Engineering.



Rajeeva Lahri

Rajeeva Lahri, PhD EE '82, is Signet Solar CEO and founder, a thin-film silicon photo voltaic modules developer and manufacturer. Lahri's many leadership positions have included

Intersil Corporation's worldwide operations CTO and Executive VP, Senior VP of Technology and Operations at Elantec, and Deputy CTO of Philips Semiconductors, and Senior VP of Corporate Technology for VLSI Technology Inc (acquired by Philips).



Douglas J. McCrosson

Douglas J. McCrosson, BS ME '84, is now Chief Operating Officer of CPI Aerostructures. He joined CPI in 2003 as Business Development Director and has held successively responsible positions there.

1990s

Sumalatha D. Adapala, BS EE '97, a Morgan Stanley former vice president, is now director of corporate development, US operations, for the non-profit Akshaya Patra Foundation, a large NGO-run meal program for school children in India. Adapala was one of the first 10 recipients of Morgan Stanley's Pay It Forward Challenge award, an initiative that taps into the entrepreneurial talents of employees to create a philanthropic legacy.

Daniel R. Bower, BS '86 PhD '96 AE, is NTSB's Engineering Chief in the Office of Research and Vehicle Performance Division. Bower joined NTSB in 1995 and specializes in aircraft performance, aircraft icing, aerodynamics, and computational fluid dynamics. Bower provided NTSB support to other agencies, including radar data and ballistic trajectory studies in support of NASA's investigation of the space shuttle Columbia accident, for which he was awarded the NASA Space Flight Awareness Team Award and a Lyndon B. Johnson Space Center Group Achievement Award. Bower received the NTSB's Dr. John K. Lauber Award in 1998 for aircraft in-flight icing research programs conducted during the Comair 3272 investigation. Before joining NTSB, Bower was a CUBRC research scientist/engineer from 1991 to 1995, and from 1988 to 1993, he was a UB MAE instructor.



Shi-Jie (Gary) Chen

Shi-Jie (Gary) Chen, PhD IE '99, has been an ISE Associate Professor at Northern Illinois University (NIU) since 2007. Prior to joining NIU, he was with Montana State University's Mechanical and Industrial Engineering department, where he earned several teaching and research awards.



John C. Dougherty

John C. Dougherty, BS EE '96, is currently the Business Development Manager for the largest technology center at SRC, formerly Syracuse Research Corporation.

Qianxi Jia, PhD CSE '91, is a laboratory fellow at Los Alamos National Laboratory. Jia has earned many awards, grants, honors, and patents, with 32 patents issued and 21 pending.



Dexter Johnson

Dexter Johnson, BS '87 MS '89 PhD '95 AE, received the elite 2010 NSBE Celestial Torch Award for Aerospace Pioneer of the Year, at the first awards ceremony specifically for African Americans in aerospace.



Anand K. Gramopadhye

Anand K. Gramopadhye, MS '89 Phd '92 ISE, is an ISE Professor and Department Chair at Clemson University.



Joseph M. Kolly

Joseph M. Kolly, PhD ME '96, is the National Transportation Safety Board's (NTSB) Office of Research and Engineering Acting Director. He has been a mechanical engineer in the same NTSB office since 1998 and has investigated several major transportation accidents, notably the 2001 TWA flight 800 accident, for which he led applied research and testing programs to investigate jet fuel chemistry, airplane fuel tank thermochemistry, jet fuel flammability and ignition energy, and computational and experimental fuel tank combustion modeling. From 1988 to 1998, Kolly was a CUBRC senior research scientist and the Facility and Operations Manager of the Large Energy National Shock (LENS) Tunnel at CUBRC.



Robin Li

Robin Li, MS CS '93, is the CEO and founder of China's dominant Internet search engine, Baidu, Inc., a nine-year old company that may be considered China's Google. Baidu recently announced it will open a separate company offering online video, comparable to YouTube. Li recently spoke to a large crowd at Stanford University, where he was also briefly interviewed by the Associated Press. The event was reported widely by media outlets, including National Public Radio and Salon.com.

Dan Matthews, BS CE '97, works for BorgWarner, which allowed him the opportunity to work and live in Germany for a period of time before returning to New York State.

Timothy McGovern, BS CIE '97, is an associate at Erdman Anthony, with over thirteen years of experience in the design and management of civil/transportation engineering projects. He is a member of the Association for Bridge Construction and Design Western New York Chapter and the Institute of Transportation Engineers.

Scott Pitcairn, BS ME '97, is with Gulfstream Aerospace Careers.



Donald P. Visco Jr.

Donald P. Visco Jr., BS '92 PhD '99 CE, was recently recognized with the American Society for Engineering Education's (ASEE) National Outstanding Teaching Award and earned the designation of ASEE fellow. Visco is a CE Professor at Tennessee Technological University, where he was awarded the 2006 Leighton E. Sissom Innovation and Creativity Award for his development of freshman CE class content.

2000s



Michael J. Dray

Michael J. Dray, BS CE '04, recently joined ZeroPoint Clean Tech, a startup biomass gasification company. Dray had been a Process Engineer at Praxair. Dray is the Engineering Alumni Association Secretary and chair of two committees.



Pascal E. Cohen

Pascal E. Cohen, AAE, BS IE '03, Air Terminal Superintendent, Buffalo Niagara International Airport, Buffalo, NY has been awarded the distinction of Accredited Airport Executive (AAE) by the American Association of Airport Executives (AAAE), a distinction held by fewer than 10 percent of AAAE's members nationwide. Cohen also holds an MBA from UB.

Victor Hang Fung, BS EE '06, is a senior electrical engineer at Motorola Mobile Devices. He had been a UB CSE student assistant.



Paul V. Gestwicki

Paul V. Gestwicki, MS '00 PhD '05 CSE, has been an Assistant Professor and Director of Undergraduate Programs at Ball State University's CS department since 2006. Prior to joining Ball State, Gestwicki served as a Teaching and Research Assistant at UB Engineering.



Jane Liu

Jane Liu, MS '03 PhD '04 CS, a Lamar University CS Assistant Professor, was awarded the NSF Faculty Early Career Development award for research on improving the speed and energy efficiency of computers that use multi-core systems. Liu is the first Lamar faculty member ever to receive this award. She received the Lamar University Merit Award in 2008.

Chris Nowak, BS '99 MEng '03 ME, is a design engineer at Carleton Technologies and an adjunct faculty member at ITT Technical Institute in Buffalo. He had been a senior mechanical engineer at Calspan Corporation.

Joseph Penepent, Jr., BS CIE '03, passed the professional engineering exam and is licensed in Indiana, with a reciprocated license in New York State. He is currently with Western NY Concrete Corp., in Batavia, NY.



Carol J. Romanowski

Carol J. Romanowski, PhD IE '04, is an Assistant Professor in the Rochester Institute of Technology's (RIT) Center for Multidisciplinary Studies and a member of the data management group in RIT's Golisano College CS department.

She is part of an RIT research team on automotive greenhouse gas policies and materials flows, as part of an NSF MUSES grant.



Richard T. Stone

Richard T. Stone, PhD IE '08, is an Assistant Professor in both the Industrial and Manufacturing Systems Engineering and the ME departments at Iowa State University. His research focus is in human performance enhancement in both physical and mental domains.

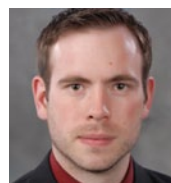

Justin T. Yates

Justin T. Yates, PhD IE '08, is an ISE Assistant Professor at Texas A&M University. He recently earned Texas A&M's College of Engineering Big 12 Faculty Fellowship, which supports efforts in multidisciplinary collaborations across the Big 12 universities. At UB, Yates was an NSF IGERT fellow specializing in Geographic Information Science.

Abbreviations Used in the Buffalo Engineer

Departments

- BME, Biomedical Engineering
- CBE, Chemical and Biological Engineering
- CSEE, Civil, Structural and Environmental Engineering
- CSE, Computer Science and Engineering
- EE, Electrical Engineering
- ISE, Industrial and Systems Engineering
- MAE, Mechanical and Aerospace Engineering

Degrees

- AE, Aerospace Engineering
- CE, Chemical Engineering
- CIE, Civil Engineering
- CompE, Computer Engineering
- CS, Computer Science
- EE, Electrical Engineering
- EnvE, Environmental Engineering
- ES, Engineering Science
- IE, Industrial Engineering
- ME, Mechanical Engineering

*denotes dues-paying Alumni Association members

Engineers Week 2010

UB Engineering students participated in a week-long celebration of Engineers Week, which enjoyed a great turnout for its many challenges and fun events. A special thanks for a job well done by Carolyn Pokora, UB Student Association Engineering Club Coordinator (below). Pictured clockwise: AE student Sandra Czarnecki puzzles over her Lego spaceship creation; CS student Dave Berquist explains the steps of his team's Rube Goldberg machine (Engineering Undergraduate Associate Dean, CSEE Professor John Van Benschoten, in back); AE student and UB AIAA President John Sisti (right) and AE grad student Thomas Leach with their completed circuit; and Mr. and Mrs. Engineer: Engineers for a Sustainable World Vice President, AE student Mike Alcazaren and graduate CSE student Jamie A. D. Szafran.

UB School of Engineering and Applied Sciences

University at Buffalo The State University of New York

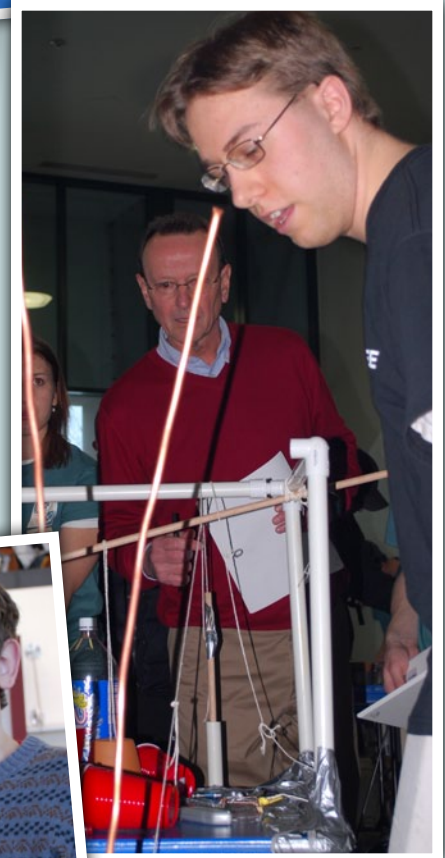

Please visit www.eng.buffalo.edu to learn about School events.

This is a publication of the School of Engineering and Applied Sciences Office of External Affairs and the Engineering Alumni Association, University at Buffalo. Anyone wishing more information on the articles contained herein may contact External Affairs: 716.645.0966; 716.645.2495 (fax); or ub-seas@eng.buffalo.edu.

*Robert E. Barnes, Editor-in-Chief
Debra Steckler, Editor

External Affairs
UB Engineering Dean's Office
412 Bonner Hall
University at Buffalo
Buffalo, NY 14260-1900