



*A National Center of Excellence in Advanced Technology Applications*

ISSN 1520-295X

# Response History Analysis of Structures with Seismic Isolation and Energy Dissipation Systems: Verification Examples for Program SAP2000

by

Joern Scheller and Michael C. Constantinou  
University at Buffalo, State University of New York  
School of Civil, Structural and Environmental Engineering  
Ketter Hall  
Buffalo, New York 14260-4300

Technical Report MCEER-99-0002

February 22, 1999

This research was conducted at the University at Buffalo, State University of New York and was supported in whole or in part by the National Science Foundation under Grant No. CMS 97-01471.

## NOTICE

This report was prepared by the University at Buffalo, State University of New York as a result of research sponsored by the Multidisciplinary Center for Earthquake Engineering Research (MCEER) through a grant from the National Science Foundation and other sponsors. Neither MCEER, associates of MCEER, its sponsors, University at Buffalo, State University of New York, nor any person acting on their behalf:

- a. makes any warranty, express or implied, with respect to the use of any information, apparatus, method, or process disclosed in this report or that such use may not infringe upon privately owned rights; or
- b. assumes any liabilities of whatsoever kind with respect to the use of, or the damage resulting from the use of, any information, apparatus, method, or process disclosed in this report.

Any opinions, findings, and conclusions or recommendations expressed in this publication are those of the author(s) and do not necessarily reflect the views of MCEER, the National Science Foundation, or other sponsors.

**Response History Analysis of Structures with  
Seismic Isolation and  
Energy Dissipation Systems:  
Verification Examples for Program SAP2000**

by

Joern Scheller and Michael C. Constantinou

Publication Date: February 22, 1999

Submittal Date: November 10, 1998

Technical Report MCEER-99-0002

Task Number 98-2403

NSF Master Contract Number CMS 97-01471

- 1 Graduate Assistant, Department of Civil, Structural and Environmental Engineering, University at Buffalo, State University of New York
- 2 Professor, Department of Civil, Structural and Environmental Engineering, University at Buffalo, State University of New York

MULTIDISCIPLINARY CENTER FOR EARTHQUAKE ENGINEERING RESEARCH  
University at Buffalo, State University of New York  
Red Jacket Quadrangle, Buffalo, NY 14261

---



## Preface

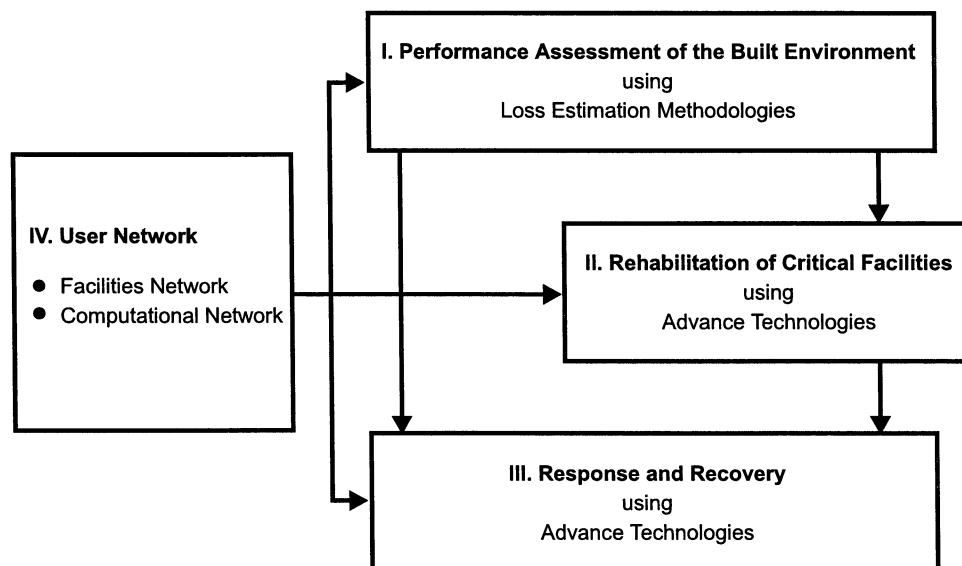
The Multidisciplinary Center for Earthquake Engineering Research (MCEER) is a national center of excellence in advanced technology applications that is dedicated to the reduction of earthquake losses nationwide. Headquartered at the University at Buffalo, State University of New York, the Center was originally established by the National Science Foundation in 1986, as the National Center for Earthquake Engineering Research (NCEER).

Comprising a consortium of researchers from numerous disciplines and institutions throughout the United States, the Center's mission is to reduce earthquake losses through research and the application of advanced technologies that improve engineering, pre-earthquake planning and post-earthquake recovery strategies. Toward this end, the Center coordinates a nationwide program of multidisciplinary team research, education and outreach activities.

MCEER's research is conducted under the sponsorship of two major federal agencies: the National Science Foundation (NSF) and the Federal Highway Administration (FHWA), and the State of New York. Significant support is derived from the Federal Emergency Management Agency (FEMA), other state governments, academic institutions, foreign governments and private industry.

The Center's NSF-sponsored research is focused around four major thrusts, as shown in the figure below:

- quantifying building and lifeline performance in future earthquake through the estimation of expected losses;
- developing cost-effective, performance based, rehabilitation technologies for critical facilities;
- improving response and recovery through strategic planning and crisis management;
- establishing two user networks, one in experimental facilities and computing environments and the other in computational and analytical resources.



*SAP2000 is the latest version in the popular SAP series of commercial structural analysis programs. It was released in 1997 and can be used for the dynamic analysis of structures with seismic isolation and energy dissipation systems. In this report, five examples are used to verify the results obtained by SAP2000. Three of the examples involved seismically isolated structures: an 8-story building isolated with bearings, a liquid storage tank isolated with a friction pendulum isolation system, and a 7-story building model isolated with a friction pendulum system. Results from the 3D-BASIS analysis program and experimental testing were compared to the SAP2000 analysis, and produced excellent agreement. The other two examples involved structures with energy dissipation devices: a 3-story building model with linear and nonlinear viscous fluid dampers, and a model with a toggle brace-damper energy dissipation system. Results from the ANSYS analysis program and experimental testing were compared to the SAP2000 analysis, where most results were in good agreement. However, SAP2000 under-predicted the displacement response of the structure tested with nonlinear viscous dampers.*

*The input files for the programs used, the history of the seismic excitation and the experimental results are located in the Publications section of MCEER's web site (<http://mceer.buffalo.edu/pubs.html>).*

## ABSTRACT

SAP2000 is a recently released commercial structural analysis program with capabilities for dynamic analysis of structures with seismic isolation and energy dissipation systems. This report presents five verification examples in which results obtained by SAP2000 are compared to experimental results and to results obtained by programs 3D-BASIS and ANSYS. Three of the examples involve seismically isolated structures, of which one was tested on the shake table under conditions resulting in bearing uplift. The other two examples involve structures with linear and nonlinear fluid viscous energy dissipation devices, which were also tested on the shake table. In general, SAP2000 produced results in excellent agreement with other analysis programs and in good agreement with experimental results, except for the case of the structure tested with nonlinear viscous damping devices. In this case, SAP2000 underpredicted the displacement response of the structure.





## **ACKNOWLEDGEMENTS**

Partial financial support for this project was provided by the Multidisciplinary Center for Earthquake Engineering Research, Project No. 98-2403. The authors are grateful to Dr. Andrew S. Whittaker for his comprehensive review of this report.



## TABLE OF CONTENTS

SECTION	TITLE	PAGE
<b>1</b>	<b>INTRODUCTION</b>	<b>1</b>
<b>2</b>	<b>ANALYSIS OF AN 8-STORY SEISMICALLY ISOLATED BUILDING WITH BEARINGS</b>	<b>5</b>
2.1	Introduction	5
2.2	Description of Analyzed Structure	7
2.3	Modeling in 3D-BASIS-ME and SAP2000	9
2.4	Comparison of Results	13
<b>3</b>	<b>ANALYSIS OF A LIQUID STORAGE TANK WITH THE FRICTION PENDULUM ISOLATION SYSTEM</b>	<b>25</b>
3.1	Introduction	25
3.2	Description of Analyzed Liquid Storage Tank	27
3.3	Modeling of Liquid Storage Tank in 3D-BASIS-ME	29
3.4	Modeling of Liquid Storage Tanks in SAP2000	30
3.5	Comparison of Results	35
<b>4</b>	<b>ANALYSIS OF EXPERIMENTAL RESPONSE OF A 7-STORY BUILDING MODEL WITH FRICTION PENDULUM ISOLATION SYSTEM</b>	<b>43</b>
4.1	Introduction	43
4.2	Description of Tested Structure	43
4.3	Modeling in SAP2000	46
4.4	Analysis Results and Comparison to Experiment	50
<b>5</b>	<b>ANALYSIS OF EXPERIMENTAL RESPONSE OF A 3-STORY BUILDING MODEL WITH LINEAR AND NONLINEAR VISCOUS FLUID DAMPERS</b>	<b>61</b>
5.1	Introduction	61
5.2	Description of Tested Structure	61
5.3	Modeling in SAP2000	64
5.4	Analysis Results and Comparison to Experiment	67

## TABLE OF CONTENTS (continued)

SECTION	TITLE	PAGE
<b>6</b>	<b>ANALYSIS OF EXPERIMENTAL RESPONSE OF A MODEL WITH A TOGGLE BRACE-DAMPER ENERGY DISSIPATION SYSTEM</b>	<b>75</b>
6.1	Introduction	75
6.2	Description of Tested Structure	75
6.3	Modeling in SAP2000	79
6.4	Analysis Results and Comparison to Experiment	79
<b>7</b>	<b>CONCLUSIONS</b>	<b>87</b>
<b>8</b>	<b>REFERENCES</b>	<b>89</b>

## LIST OF ILLUSTRATIONS

FIGURE	TITLE	PAGE
2-1	Plan View of the Base of the Building Model and Location of the Isolation Bearings	8
2-2	Illustration of SAP2000 Model of 8-story Seismic-Isolated Building	12
2-3	Comparison of Calculated Force-Displacement Loops for Corner Bearing	14
2-4	Comparison of Calculated Force-Displacement Loops for Center Bearing	15
2-5	Comparison of Calculated 8th Story Drift Histories	16
2-6	Comparison of Calculated 3rd Story Drift Histories	17
2-7	Comparison of Calculated 8th Floor Acceleration Histories	18
2-8	Comparison of Calculated 3rd Floor Acceleration Histories	19
2-9	Comparison of Calculated Relative Story Rotation Histories	20
2-10	Comparison of Calculated Force-Displacement Loops for Corner Bearing when the Actual Value of $k_e$ is Used	22
2-11	Comparison of Calculated Force-Displacement Loops for Center Bearing when the Actual Value of $k_e$ is Used	23
3-1	Geometry of Isolated Water Tank	28
3-2	Configuration of Isolation System	28
3-3	Mathematical Model of Liquid Storage Tank	29
3-4	Model of Liquid Storage Tank in 3D-BASIS-ME	31
3-5	Location of Clusters of Bearings in 3D-BASIS-ME	32
3-6	Comparison of Calculated Force-Displacement Loops for Central Cluster of Bearings (No. 5)	36

## LIST OF ILLUSTRATIONS (continued)

FIGURE	TITLE	PAGE
3-7	Comparison of Calculated Force-Displacement Loops for Exterior Cluster of Bearings (No. 1)	37
3-8	Comparison of Calculated Displacements of Sloshing Fluid	38
3-9	Comparison of Calculated Displacements of Fluid-Tank Mode	39
3-10	Comparison of Calculated Accelerations of Sloshing Fluid	40
3-11	Comparison of Calculated Accelerations of Fluid-Tank Mode	41
4-1	Elevations and Plan View of Tested Structure	44
4-2	Model of 7-story Isolated Structure in SAP2000	47
4-3	Comparison of Analytical and Experimental Results on the Base Shear-Displacement Loop and Isolation System Displacement History	52
4-4	Comparison of Analytical and Experimental Results on Selected Histories of Story Drift and Story Shear Force	53
4-5	Comparison of Analytical and Experimental Results on the 7th Floor Acceleration	54
4-6	Comparison of Analytical and Experimental Shear Force-Bearing Displacement Loops	55
4-7	Comparison of Analytical and Experimental Results on the Base Shear Displacement Loop. Analysis without Damping Elements	58
4-8	Comparison of Analytical and Experimental Results on Shear Force-Displacement Loops. Analysis with Vertical Elements and Realistic Values of Linear Effective Stiffness	59
5-1	Schematic of Tested Model	63
5-2	Schematic of One of the Tested Configurations	64
5-3	Illustration of SAP2000 Model of 3-story Frame with Viscous Dampers	65

## LIST OF ILLUSTRATIONS (continued)

FIGURE	TITLE	PAGE
5-4	Comparison of Analytical and Experimental Normalized Story Shear Force-Drift Loops of Structure with Linear Dampers (linear analysis type, linear damper model)	68
5-5	Comparison of Analytical and Experimental Histories of Drift of Structure with Linear Dampers (linear analysis type, linear damper model)	69
5-6	Comparison of Analytical and Experimental Normalized Story Shear Force-Drift Loops of Structure with Linear Dampers (nonlinear analysis type, nonlinear damper model with $c_{exp} = 1.0$ )	71
5-7	Comparison of Analytical and Experimental Normalized Story Shear Force-Drift Loops of Structure with Nonlinear Dampers	72
5-8	Comparison of Analytical and Experimental Histories of Drift of Structure with Nonlinear Dampers	73
6-1	Tested Frame with Toggle Brace-Damper System	76
6-2	View of Tested Structure with Upper Damper Configuration on the Shaking Table	77
6-3	Schematic Illustrating Joints and Elements in ANSYS Model of Frame with Rigid-Simple Connections (for coordinates and section properties see Appendix F)	80
6-4	Schematic Illustrating Location of Lumped Masses in ANSYS Model of Frame (values denote weight in pounds)	81
6-5	Comparison of Analytical and Experimental Results on History of Frame Drift	83
6-6	Comparison of Analytical and Experimental Damper Force-Displacement Loops	84
6-7	Comparison of Analytical and Experimental Histories of Acceleration of Beam to Column Connection	85





## LIST OF TABLES

<b>TABLE</b>	<b>TITLE</b>	<b>PAGE</b>
2-1	Properties of Analyzed Structure	7
2-2	Comparison of Calculated Periods and Mode Shapes of 8-story Superstructure (fixed base)	10
4-1	Experimental and Analytical Modal Properties of Non-isolated 7-story Model	51
5-1	Experimental and Analytical Modal Properties of 3-story Model without Dampers	67



## SECTION 1

### INTRODUCTION

Seismic isolation and energy dissipation technologies have found an increasing number of applications over the last decade and particularly over the last few years following the 1994 Northridge earthquake. The increase in the use of these technologies may be attributed to (a) the further development of these technologies and the transfer of technologies from other disciplines, (b) the need to retrofit or rehabilitate seismically deficient structures, (c) the desire to improve performance in new construction, (d) the development of analysis and design guidelines and specifications, and (e) the availability of computer programs for dynamic analysis.

Commercially available computer programs, such as ANSYS (Swanson Analysis Systems, 1996) and ABAQUS (Hibbitt et al., 1989), have been available for several years and are capable of modeling the behavior of seismic isolation and energy dissipation hardware. However, they have been rarely used for this purpose primarily because they are general purpose analysis programs not suited to the analysis of buildings.

The need for a dynamic analysis computer program dedicated to seismically isolated buildings was fulfilled in part with the release in 1989 of 3D-BASIS (Nagarajaiah et al., 1989). Various versions of this program have been released since then, of which 3D-BASIS-TABS (Reinhorn et al., 1994) and 3D-BASIS-ME (Tsopelas et al., 1994) introduced new features such as integration with program ETABS (Wilson et al., 1975), multiple superstructures, elements for viscous dampers, and vertical ground acceleration and overturning moment effects on sliding isolation bearings.

In 1997 program SAP2000 was released (Computers and Structures, 1997). As the latest version in the popular SAP series of commercial structural analysis programs, SAP2000 has the feature of nonlinear dynamic analysis with elements for seismic isolation and energy dissipation hardware. The program has already been used for the analysis of a number of structures with seismic isolation or energy dissipation systems, and has the potential for widespread use.

In this report, a series of verification examples for SAP2000 are presented involving seismic isolation and energy dissipation systems. Two of the problems are special structural systems in which a specific type of behavior is sought (e.g., shear-type representation, exclusion of overturning moment effects, etc.). Results obtained by SAP2000 are compared with results obtained by program 3D-BASIS-ME (Tsopelas et al., 1994). Three more examples involve structures tested in the laboratory for which experimental results are available. They include one structure with Friction Pendulum isolation bearings under extreme conditions of dynamic loading that induce bearing uplift, and two structures with linear and nonlinear viscous fluid dampers. Moreover, in one of the last three problems, the SAP2000 results are compared to those obtained by program ANSYS (Swanson Analysis Systems, 1996).

In general, modeling in SAP2000 was successful in producing results that were either nearly identical to those of programs 3D-BASIS-ME and ANSYS or in favorable agreement with experimental results. However, modeling in SAP2000 was not always straightforward and in some cases, an uncommon combination of elements was used to obtain the correct response. Moreover, the nonlinear viscous damper element in SAP2000 was observed to lead to underestimation of story drifts in the analysis of a

tested 3-story structure. However, the same model performed properly in the analysis of simple single degree of freedom systems.

In the verification examples, a mixture of units in the SI and in the American systems were used, exactly as they were used in the original publications of the analytical or experimental results which were used to verify SAP2000.

The input files for the programs used, the history of the seismic excitation and the experimental results are provided on MCEER's web site at <http://mceer.buffalo.edu>.



## SECTION 2

### ANALYSIS OF AN 8-STORY SEISMICALLY ISOLATED BUILDING WITH BEARINGS

#### 2.1 Introduction

In this example, a rather simple representation of a seismically isolated building is analyzed using SAP2000 (Computer and Structures, 1997) and the results are compared to results obtained with program 3D-BASIS-ME (Tsopelas et al., 1994). Due to the simplicity of the model for this structural system—shear-type representation with bilinear hysteretic isolators—3D-BASIS-ME is believed to produce accurate results. Accordingly, the example serves the purpose of demonstrating the SAP2000 input and particularly the configuration of the **Nlink** element for producing output that is nearly identical to that of 3D-BASIS-ME.

The analyzed structural system has been used by Theodossiou and Constantinou (1991) and Winters and Constantinou (1993) in the evaluation of the SEAOC/UBC analysis procedures for seismically isolated structures. In these studies, an 8-story building superstructure was modeled as shear-type frame with its properties specified in terms of the floor masses and moments of inertia, story shear and rotational stiffnesses, eccentricities and modal damping ratios. The isolation system consisted of 45 isolators with bilinear hysteresis

There are various options for modeling shear-type behavior in SAP2000. One option is to utilize the **Frame** element for columns with appropriate axial stiffness so that they are effectively inextensible. Another option is to use the **Nlink** element in the

**damper** property type. This element is described in the SAP2000 Analysis Reference (Computer and Structures, 1997) as a Maxwell element, that is, an element consisting of a damper and a spring in series. There is no mention in the SAP2000 Analysis Reference as to how this element may be used to represent a pure spring. One would expect that by specifying a large value for the damping coefficient **c**, pure spring behavior could be obtained, but such behavior is obtained in SAP2000 when **c** is specified to be zero.

The isolation bearings, which have bilinear hysteretic behavior, were modeled with element **Nllink** in the **Isolator1** property type. This element has coupled bilinear hysteretic behavior for the two shear deformations, whereas the remaining four degrees of freedom (axial deformation and three rotations) are linear. Among the parameters describing this model, the **linear effective stiffness ke** for the two nonlinear degrees of freedom needs to be specified. This parameter is not directly used for the nonlinear time-history analysis. Rather, it is used indirectly. According to the SAP2000 Analysis Reference its selected value may affect the rate of convergence in the iterative solution procedure; no mention is made as to the effect of the selected value on the accuracy of the solution.

It appears that an appropriate value of the **linear effective stiffness** for the nonlinear degrees of freedom is the effective stiffness of the isolator as, for example, is defined in the Uniform Building Code (e.g., International Conference of Building Officials, 1994). When such a value is used, the calculated frequencies and mode shapes of the structure are meaningful and useful for response-spectrum analysis. However, we observed that when this value is used in nonlinear time-history analysis, the calculated response is incorrect. Specifically, the isolation-system displacements are



underestimated. On the other hand, correct results are obtained when the value of  $k_e$  is specified to be very small but not zero (a zero value would result in an unstable system and execution of the program is aborted).

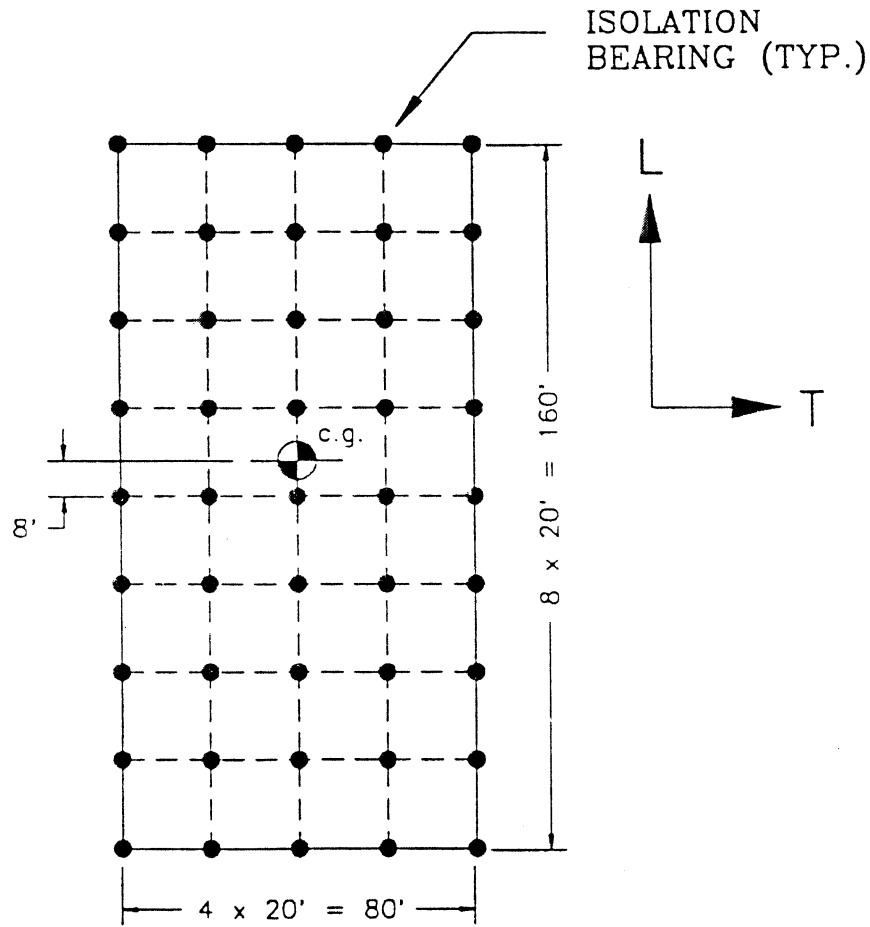
## 2.2 Description of Analyzed Structure

The structure is an eight-story building with plan dimensions of 160 ft by 80 ft with a story height of 12 ft. The properties of the structure in a shear-type representation are given in Table 2-1. In this representation the center of resistance of each story is located at the geometric center, whereas the center of mass of each floor and of the isolation basemat is located at distance of 8 ft from the geometric center as illustrated in Figure 2-1.

**Table 2-1 Properties of Analyzed Structure**

Story / Floor	Weight (kips)	Rotational Inertia (kips-in-sec <sup>2</sup> )	Stiffness (kips/in)	Rotational Stiffness (kips-in)	Eccentricity (ft)	
					Longitudinal	Transverse
8	1280	1272642.5	1700.9	1997933760	8	0
7	1280	1272642.5	1700.9	1997933760	8	0
6	1280	1272642.5	2551.3	2996900640	8	0
5	1280	1272642.5	2551.3	2996900640	8	0
4	1280	1272642.5	2551.3	2996900640	8	0
3	1280	1272642.5	3401.8	3995867520	8	0
2	1280	1272642.5	3401.8	3995867520	8	0
1	1280	1272642.5	3401.8	3995867520	8	0
Base	1280	1272642.5			8	0

Figure 2-1 shows also the location of the 45 isolation bearings. Each of these bearings has bilinear hysteretic behavior with yield force of 12.8 kips, yield displacement of 0.5 inch and ratio of post-yielding to elastic stiffness of 0.18868. This isolation system



**Figure 2-1 Plan View of the Base of the Building Model and Location of the Isolation Bearings**

is referred to as system type 7 for stiff soil profiles in the study of Winters and Constantinou (1993). The isolation system was configured for seismic input representative of Seismic Zone 4, soil profile S<sub>1</sub>, and at a site at least 15 km from an active fault in accordance with the 1994 Uniform Building Code (International Conference of Building Officials, 1994). On the basis of the static analysis procedure of the 1994 Uniform Building Code, the isolated-structure period is 2.0 sec, the effective damping is 0.16 and the design displacement is 5.8 in.

The seismic input for this example consisted of the recorded pair of horizontal ground acceleration histories in the 1971 San Fernando earthquake at station No. 211. Each of the two components was multiplied by a factor 2.345 in accordance with the scaling procedures described in Theodossiou and Constantinou (1991) and applied with the north and west components in the transverse and longitudinal directions of the model, respectively.

### **2.3 Modeling in 3D-BASIS-ME and SAP2000**

The model of the 8-story superstructure in program 3D-BASIS-ME utilized the shear-type option. Each of the 45 isolators was explicitly modeled using the hysteretic element for elastomeric bearings (option INELEM (K, 2) = 4). It should be noted that in 3D-BASIS-ME the inherent damping of the structure is specified in terms of the modal damping ratios for the superstructure (that is, the part of the structure above the isolation basemat, as if that part is fixed). A damping ratio of 0.03 was specified for the 27 modes used in the analysis. Given the type of modeling and constraints used, these 27 modes fully described the dynamic response.

Part of the output of program 3D-BASIS-ME contains the frequencies and mode shapes of the superstructure. This output was compared to that obtained from SAP2000 in an analysis of the structure without the isolation system (the SAP2000 model for the superstructure is described later in this report). Selected results from this comparison are presented in Table 2-2. The two programs produce nearly identical results. The SAP2000 model was developed in such a way as to closely approximate the 3D-BASIS-ME model. This did not expose the extensive features of SAP2000 for modeling a

**Table 2-2 Comparison of Calculated Periods and Mode Shapes of 8-story Superstructure (fixed base)**

Floor	Mode 1					
	SAP2000			3D-BASIS-ME		
	Longitudinal Component	Transverse Component	Rotational Component	Longitudinal Component	Transverse Component	Rotational Component
8	0.000	0.285	3.40 E-05	0.000	0.285	3.44 E-05
7	0.000	0.268	3.20 E-05	0.000	0.268	3.24 E-05
6	0.000	0.253	2.81 E-05	0.000	0.253	2.84 E-05
5	0.000	0.204	2.44 E-05	0.000	0.204	2.47 E-05
4	0.000	0.165	1.97 E-05	0.000	0.165	1.99 E-05
3	0.000	0.119	1.43 E-05	0.000	0.119	1.44 E-06
2	0.000	0.082	9.74 E-06	0.000	0.082	9.86 E-06
1	0.000	0.041	4.95 E-06	0.000	0.041	5.00 E-06
Period	1.147 sec			1.147 sec		

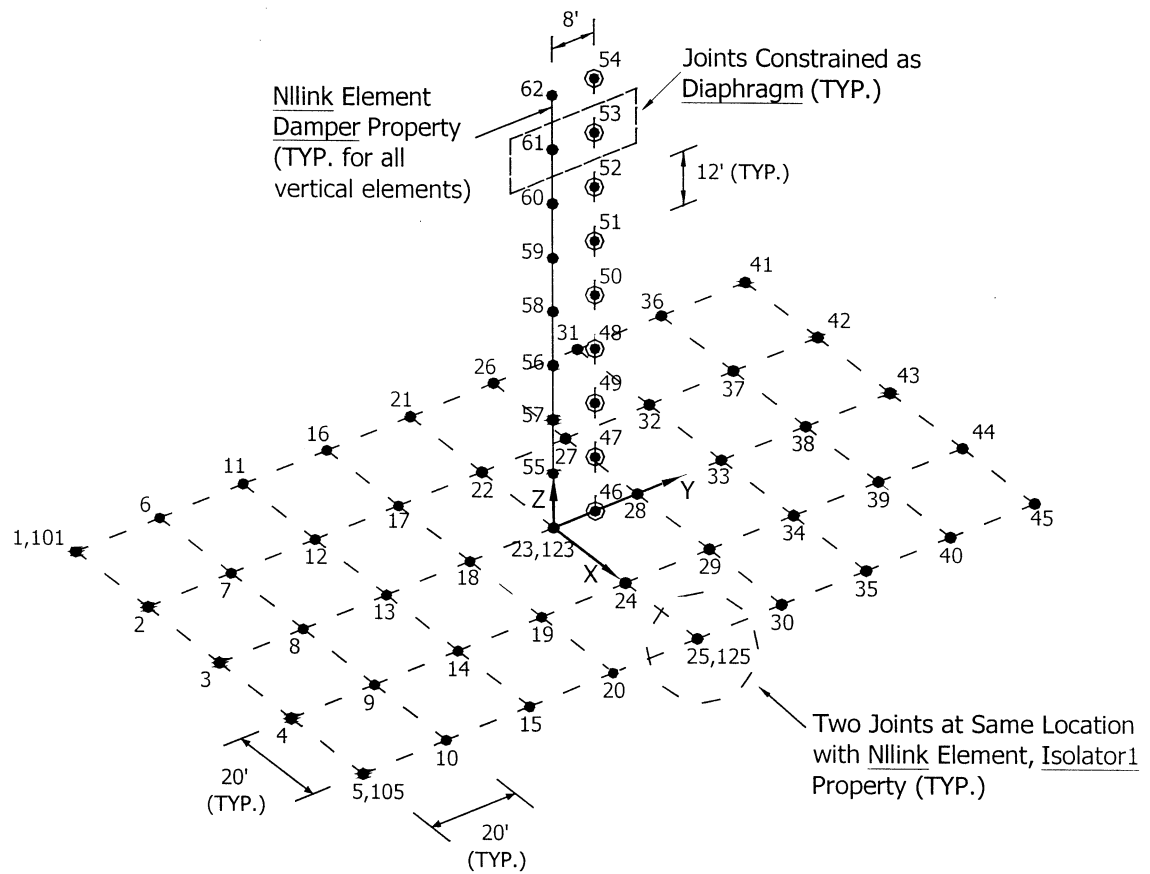
Floor	Mode 2					
	SAP2000			3D-BASIS-ME		
	Longitudinal Component	Transverse Component	Rotational Component	Longitudinal Component	Transverse Component	Rotational Component
8	0.286	0.000	0.000	0.286	0.000	0.000
7	0.269	0.000	0.000	0.269	0.000	0.000
6	0.236	0.000	0.000	0.236	0.000	0.000
5	0.205	0.000	0.000	0.205	0.000	0.000
4	0.166	0.000	0.000	0.166	0.000	0.000
3	0.120	0.000	0.000	0.120	0.000	0.000
2	0.082	0.000	0.000	0.082	0.000	0.000
1	0.042	0.000	0.000	0.042	0.000	0.000
Period	1.140 sec			1.140 sec		

Floor	Mode 9					
	SAP2000			3D-BASIS-ME		
	Longitudinal Component	Transverse Component	Rotational Component	Longitudinal Component	Transverse Component	Rotational Component
8	0.000	-0.223	-2.66 E-05	0.000	-0.223	-2.69 E-05
7	0.000	0.254	3.03 E-05	0.000	0.254	3.06 E-05
6	0.000	0.188	2.24 E-05	0.000	0.188	2.27 E-05
5	0.000	-0.124	-1.48 E-05	0.000	-0.124	-1.49 E-05
4	0.000	-0.259	-3.09 E-05	0.000	-0.259	-3.13 E-05
3	0.000	-0.025	-3.02 E-05	0.000	-0.025	-3.05 E-06
2	0.000	0.177	2.11 E-06	0.000	0.177	2.14 E-06
1	0.000	0.190	2.27 E-06	0.000	0.190	2.30 E-06
Period	1.191 sec			1.191 sec		

building. However, it allowed for a direct comparison of the results of the two programs, and particularly exposed the features of the new **Nlink** element in its **Isolator1** property.

Figure 2-2 illustrates the model. The model consists of joints 23 and 55 to 62, which are interconnected by **Nlink** elements in the **damper** property with **c** specified to be equal to zero, and with the horizontal stiffness in directions x and y, and the rotational stiffness specified in accordance with Table 2-1. The floor masses are concentrated at the eccentric joints 47 to 54, which are constrained to the adjacent joints using the **diaphragm** option. Having also specified as active degrees of freedom the UX, UY and RZ displacements, this model represents a shear-type structure.

The isolation basemat consists of joints 1 to 45 which are constrained to the basemat mass joint 46 through the **body** constraint. The 45 isolation bearings are modeled with **Nlink** elements, **Isolator1** property, which connect joints 1 to 45 to joints 101 to 145. The latter are fixed ground joints. Each of these elements was assigned the following properties: **k2** = **k3** = 25.6 kip/in (elastic horizontal stiffness), **ratio2** = **ratio3** = 0.18868 (post-yielding to elastic stiffness ratio), and **yield2** = **yield3** = 12.8 kips (yield force). Moreover, the linear effective stiffness **ke** was specified as 0.0001 kip/in for the reasons cited earlier. It should be noted that the linear effective stiffness is calculated to be 6.55 kip/in in accordance with the 1994 Uniform Building Code for a design displacement of 5.8 in. The reason for using a very low value for **ke** in nonlinear type of analysis has been explained in Section 2.1 and will become apparent when results of the analysis are presented.



NOTES:

1. ● JOINTS WITH SPECIFIED MASS AND MASS MOMENT OF INERTIA
2. JOINTS 1 TO 46 CONSTRAINED AS BODY
3. ACTIVE DEGREES OF FREEDOM ARE UX, UY AND RZ FOR JOINTS 46 TO 54

**Figure 2-2 Illustration of SAP2000 Model of 8-story Seismic-Isolated Building**

Modal damping was specified as 0.03 for each mode. Program SAP2000 utilizes the specified damping ratios in constructing a proportional damping matrix for the entire structure including the nonlinear isolation system elements, which are represented by the specified linear effective stiffnesses. In general, inherent viscous damping in the structural system (excluding that provided by energy dissipation devices) is accounted for differently in programs SAP2000 and 3D-BASIS-ME. Specifically,

- (a) 3D-BASIS-ME utilizes modal reduction, in which the superstructure is represented by a selected number of modal displacements and not the actual degrees of freedom. Accordingly, the specified damping ratios for the superstructure are directly used without construction of a damping matrix.
- (b) SAP2000 utilizes a similar approach but for the entire structure, including the degrees of freedom associated with the isolation system. Moreover, SAP2000 has the option of using Ritz vectors rather than the eigenvectors.

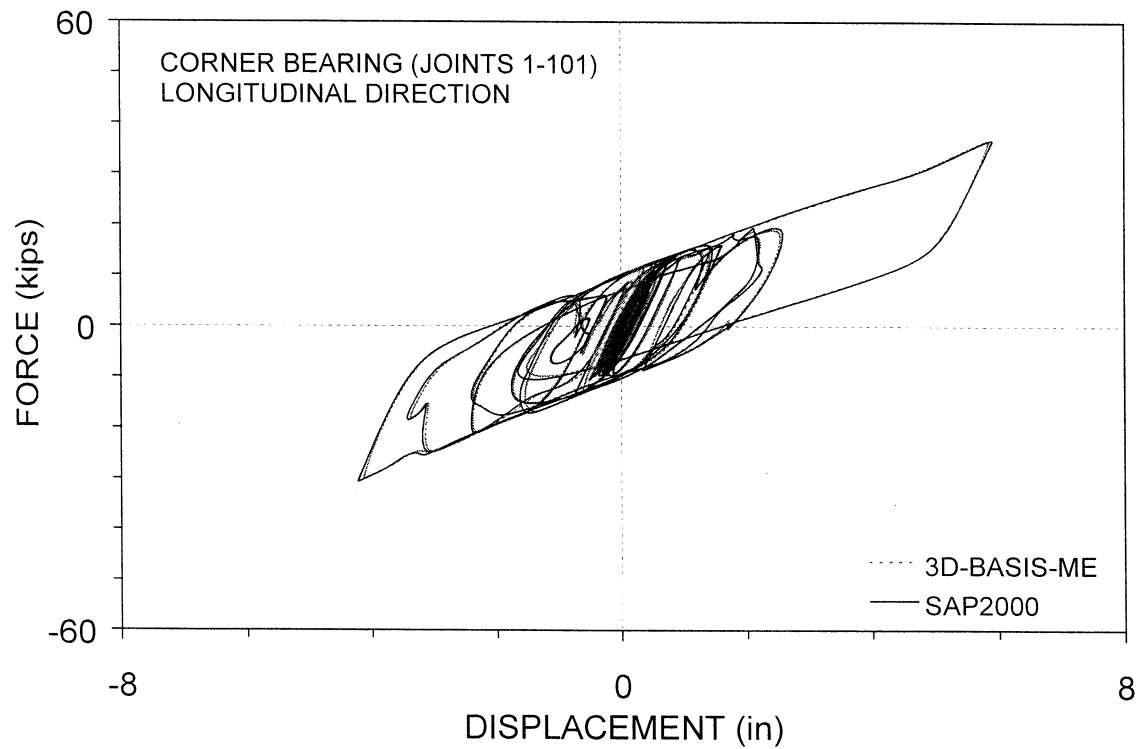
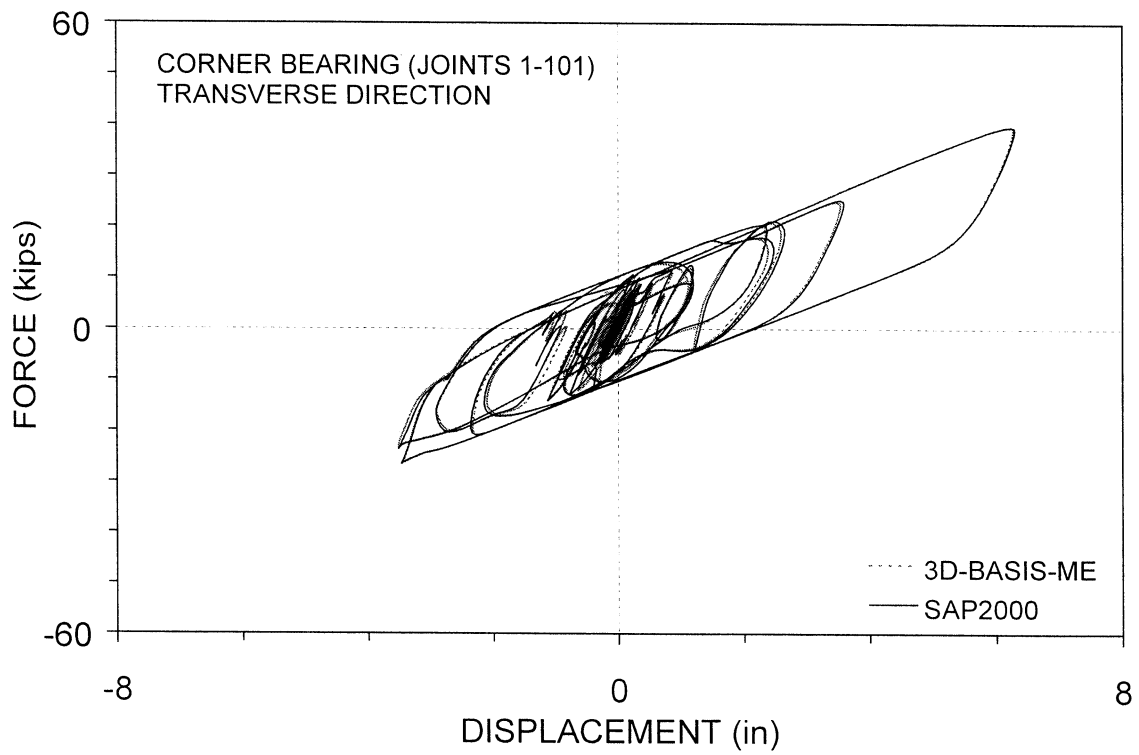
Accordingly, specification of the same damping ratios does not result in exactly the same representation of inherent damping in the two programs. However in this example, the representation is effectively the same due to (a) the small value of the damping ratio, and (b) the specified very low value of linear effective stiffness for the isolators.

Analysis in SAP2000 was performed by using all 27 eigenvectors in **nonlinear** analysis type.

## 2.4 Comparison of Results

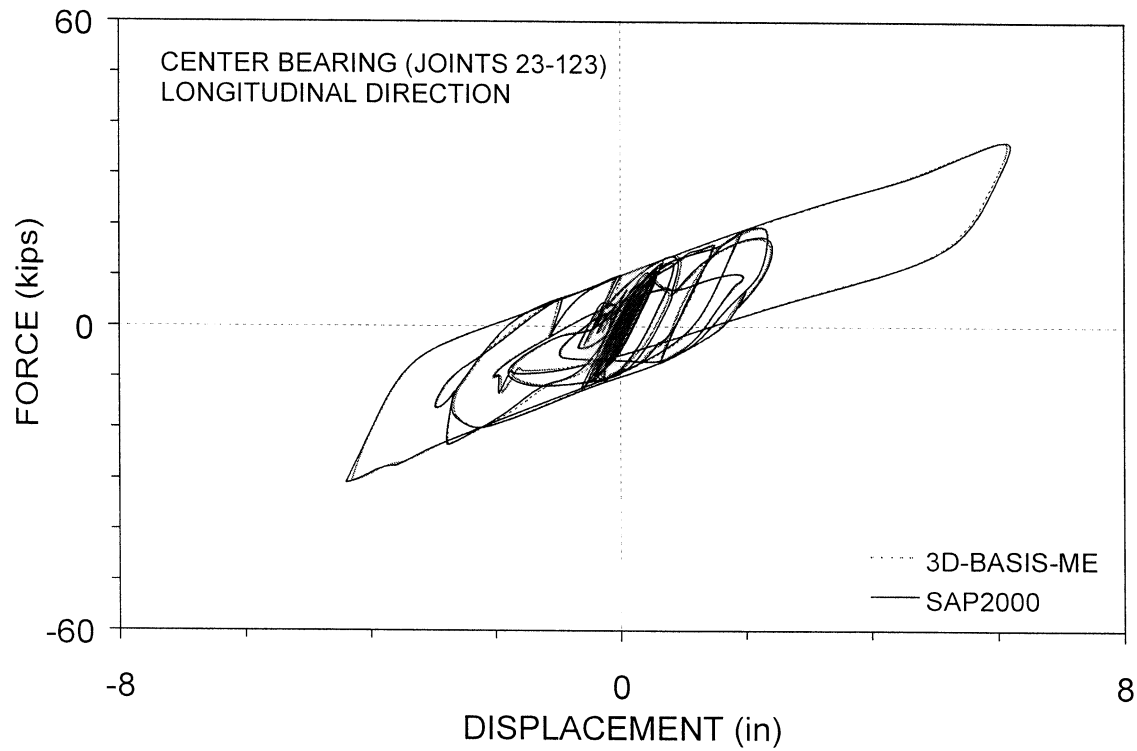
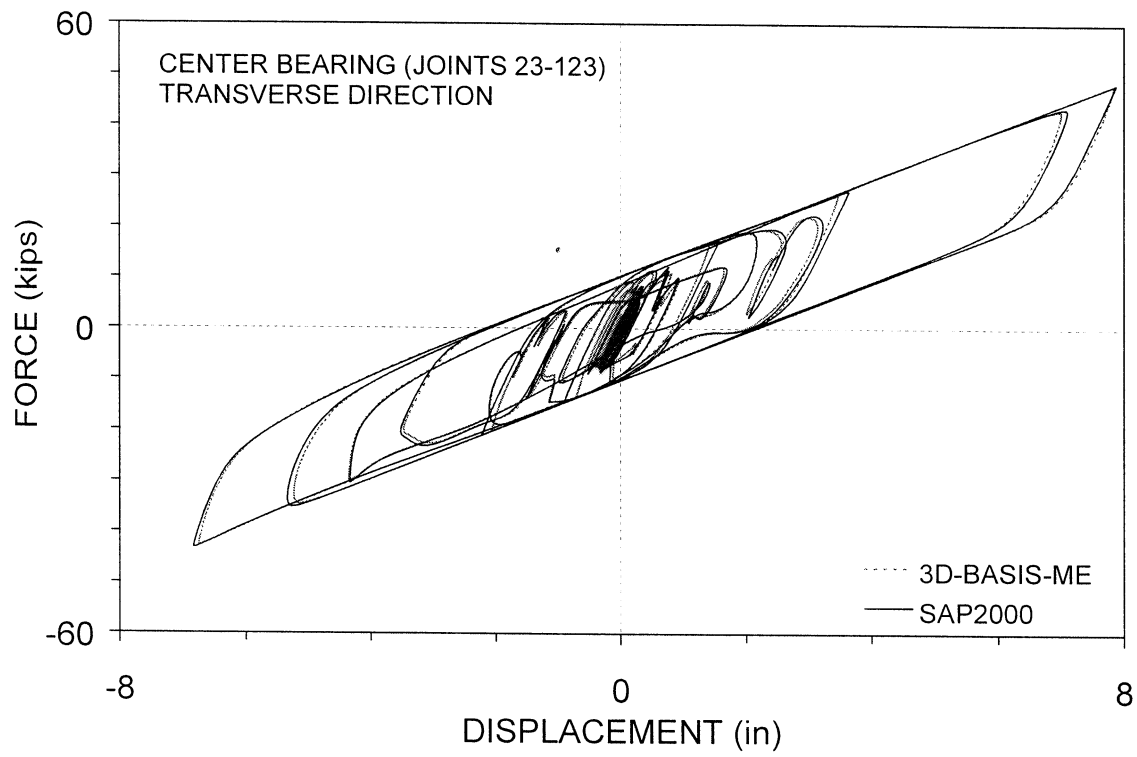
Figures 2-3 to 2-9 compare the calculated response of the structure by the two programs. The compared responses include selected bearing force-displacement loops, floor acceleration histories and histories of story drifts and story relative rotations. The results of SAP2000 are nearly identical to the results of 3D-BASIS-ME.

It should be noted that in the SAP2000 analysis, an unrealistic value for the linear effective stiffness ( $\mathbf{ke} = 0.0001$  kip/in) was used. When the actual value of  $\mathbf{ke}$  ( $= 6.55$  kip/in per 1994 UBC) is used, the results generated by SAP2000 do not agree with

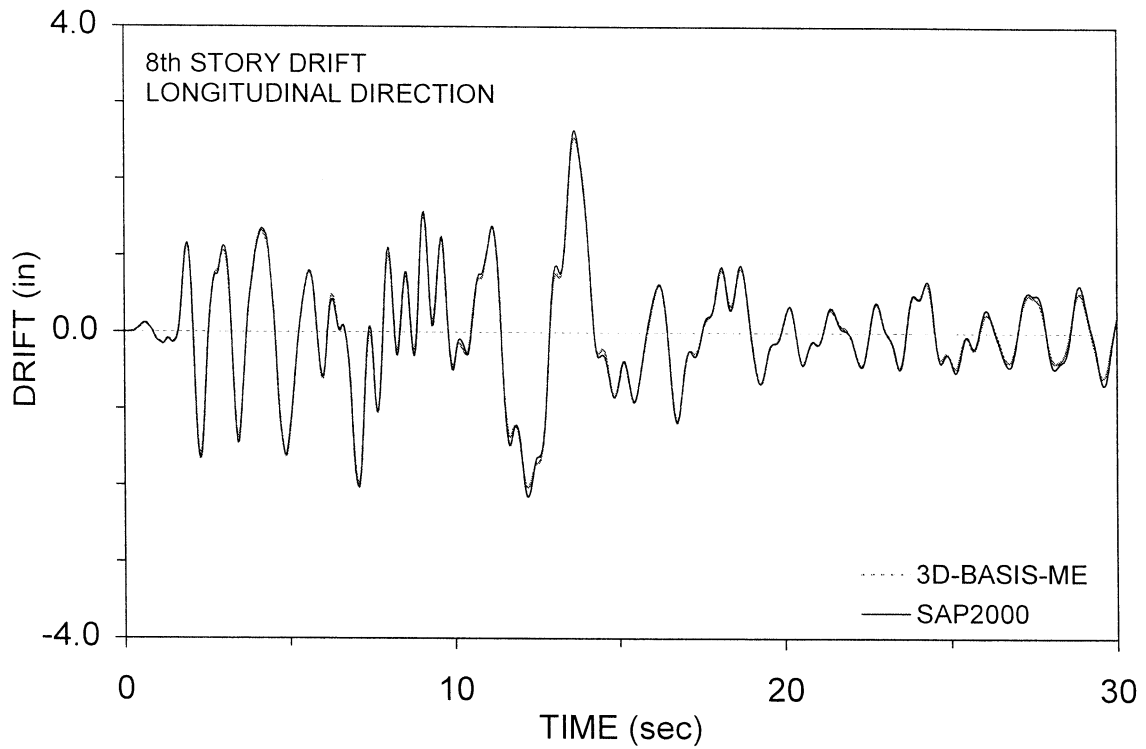
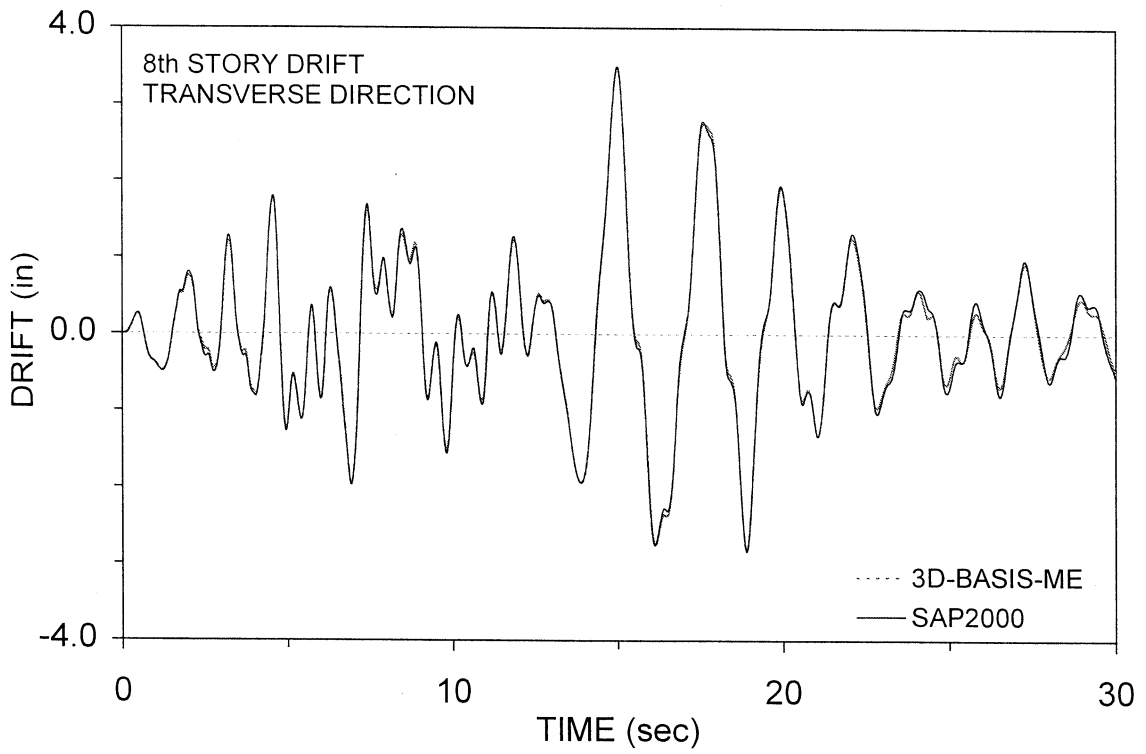


**Figure 2-3 Comparison of Calculated Force-Displacement Loops for Corner Bearing**

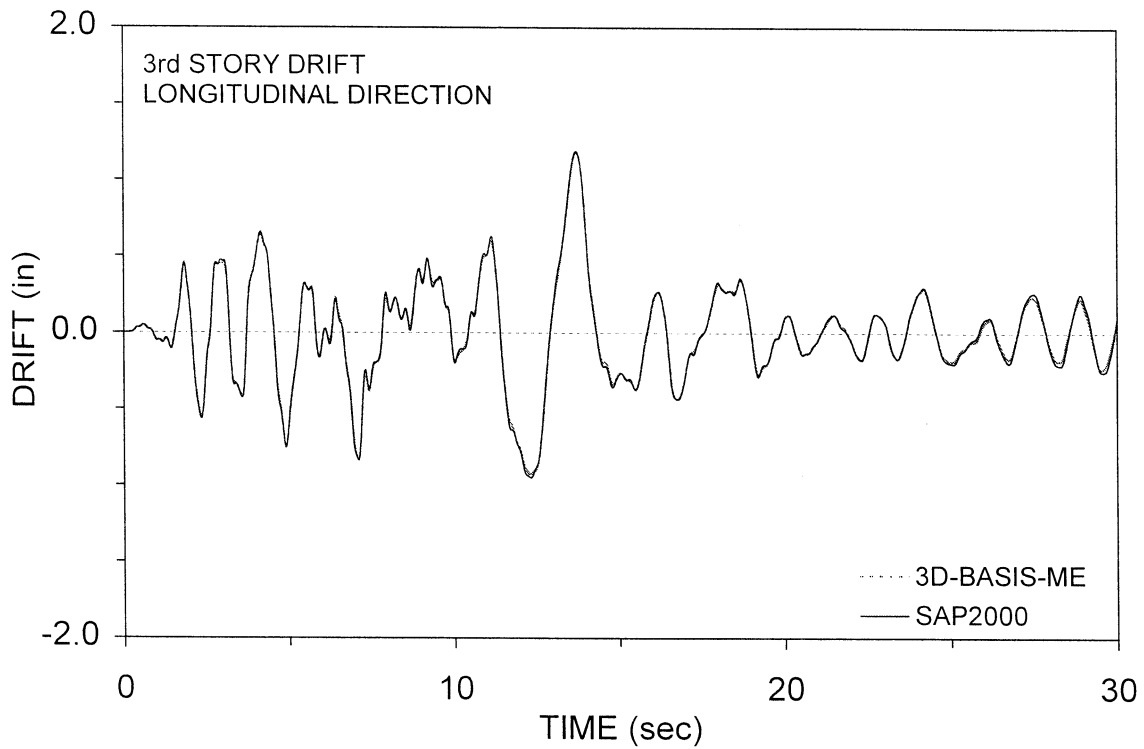
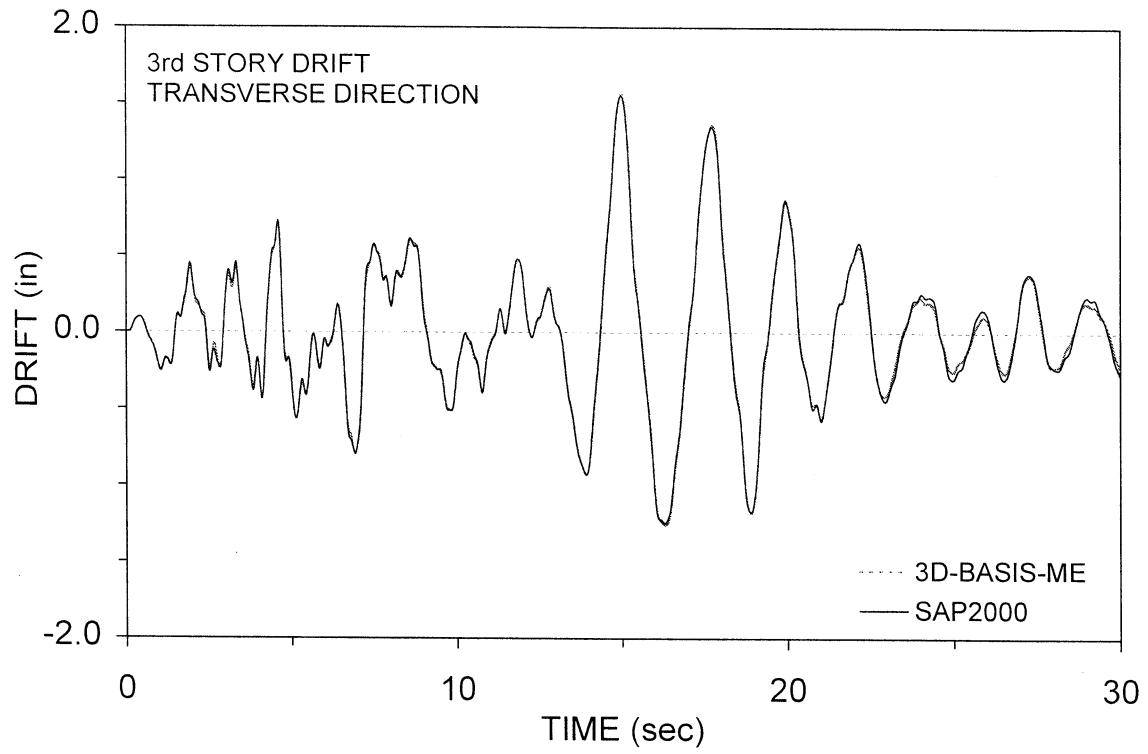




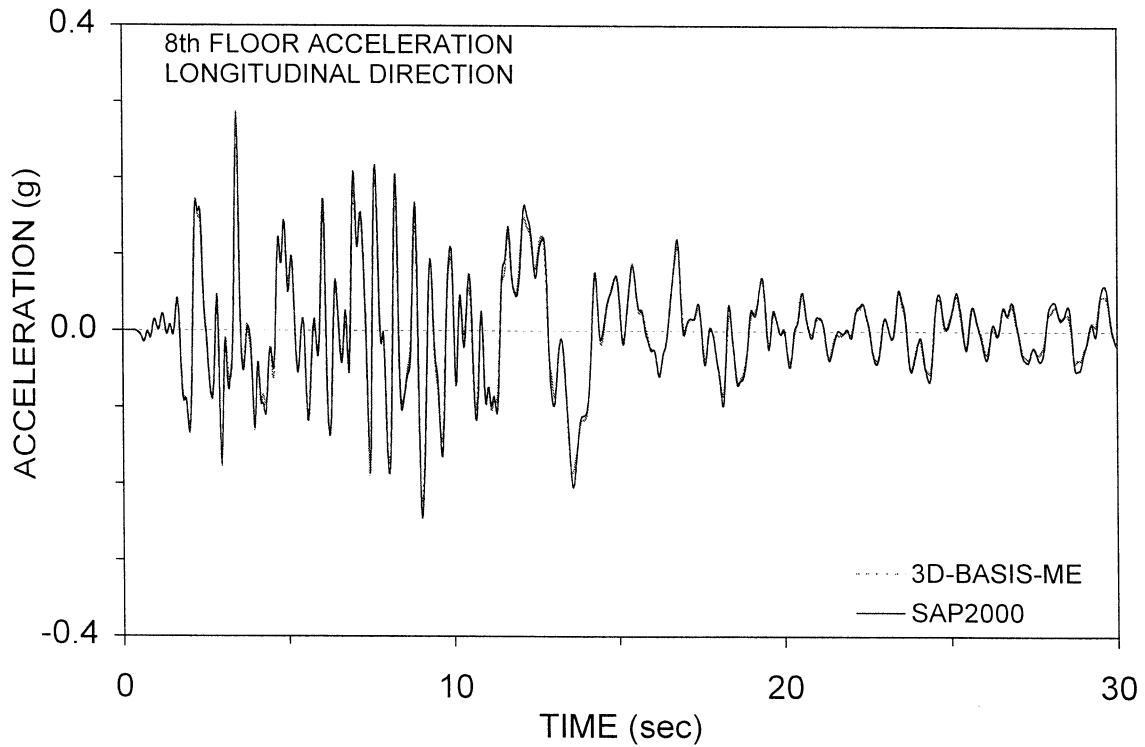
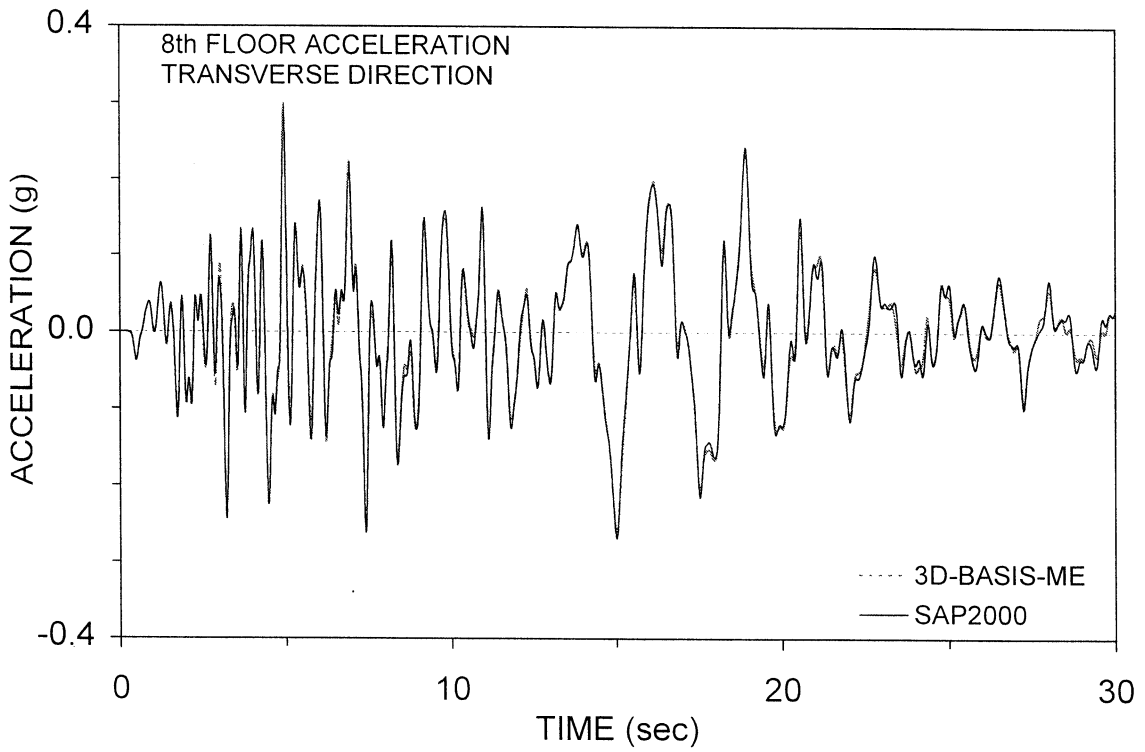
**Figure 2-4 Comparison of Calculated Force-Displacement Loops for Center Bearing**



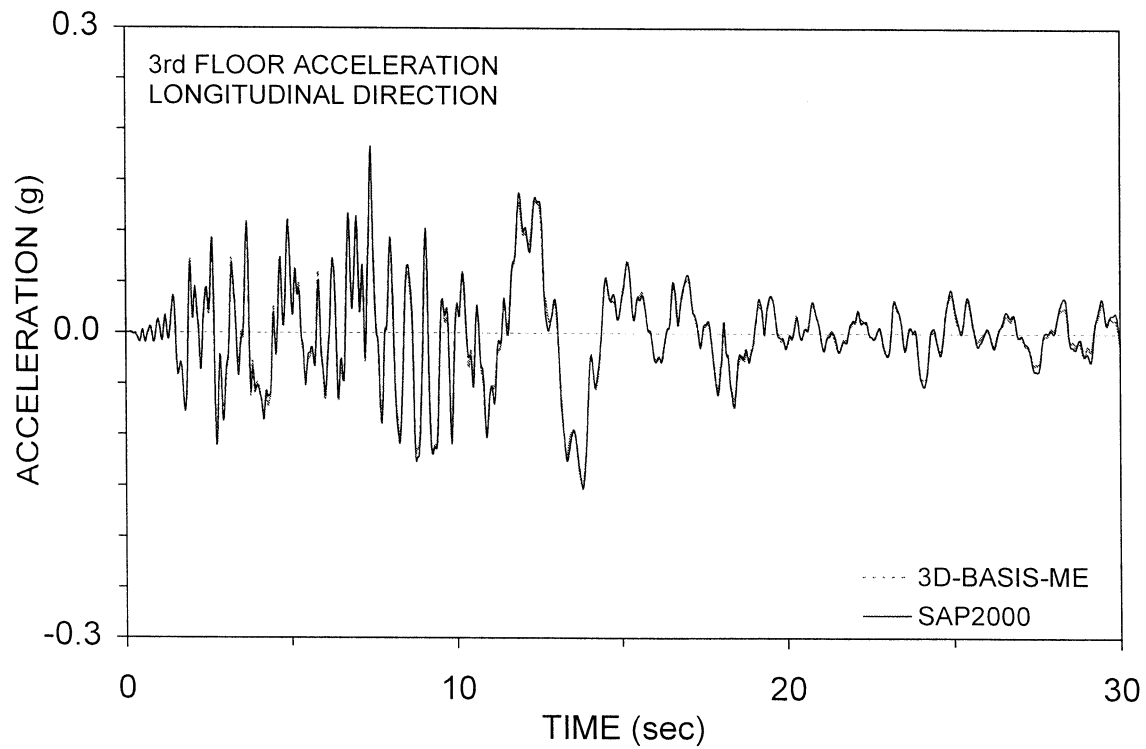
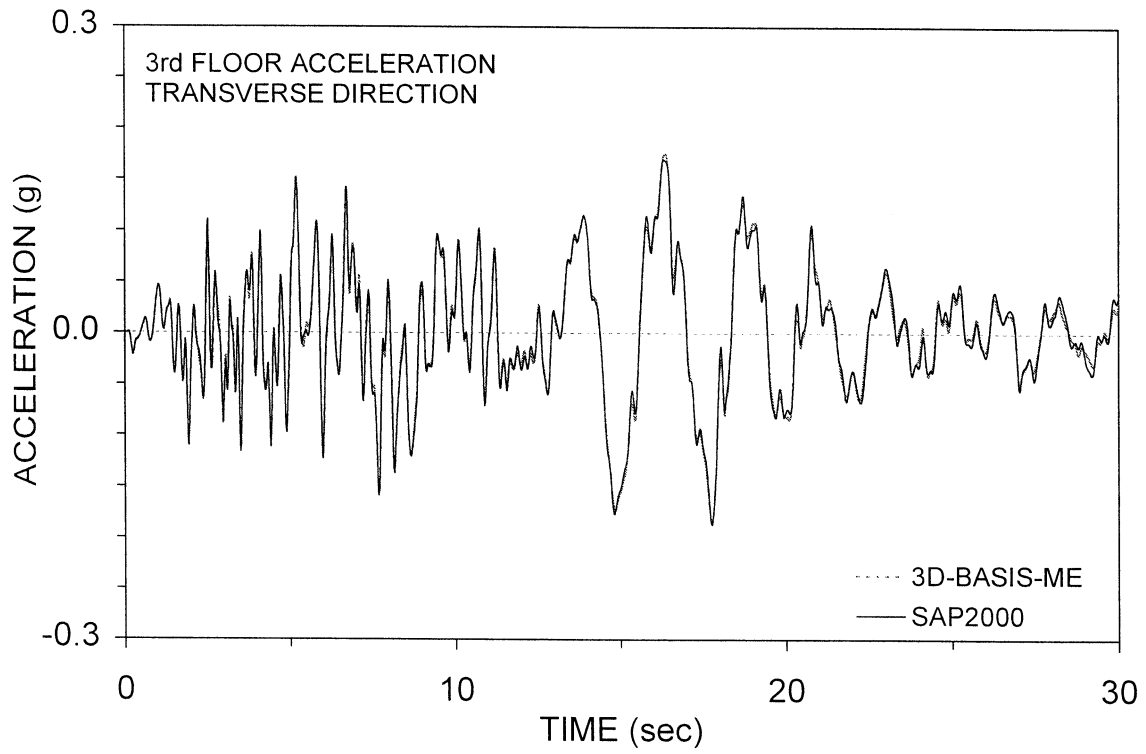
**Figure 2-5 Comparison of Calculated 8th Story Drift Histories**



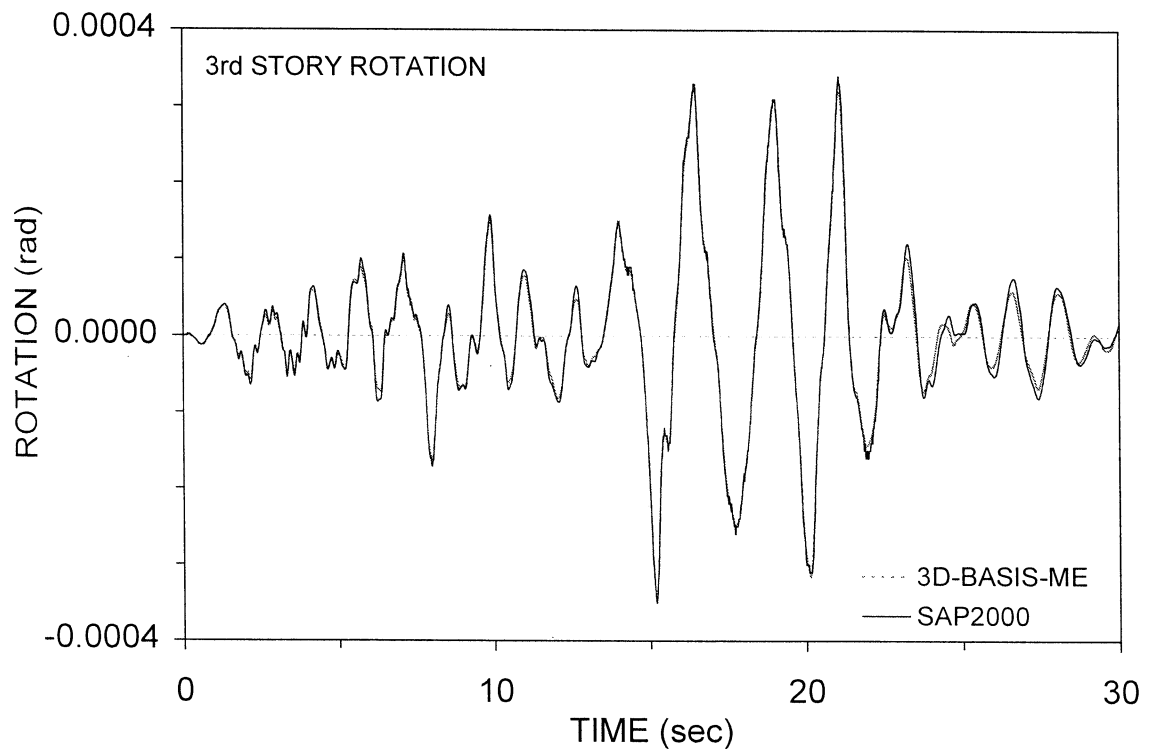
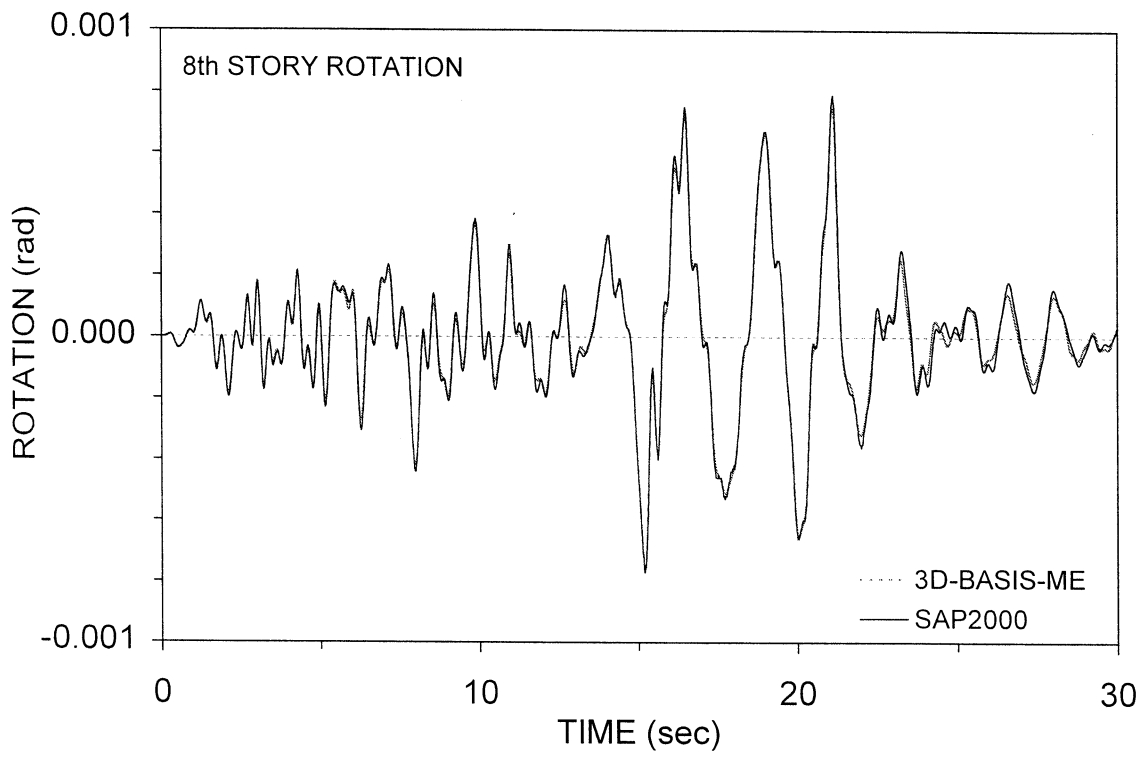
**Figure 2-6 Comparison of Calculated 3rd Story Drift Histories**



**Figure 2-7 Comparison of Calculated 8th Floor Acceleration Histories**

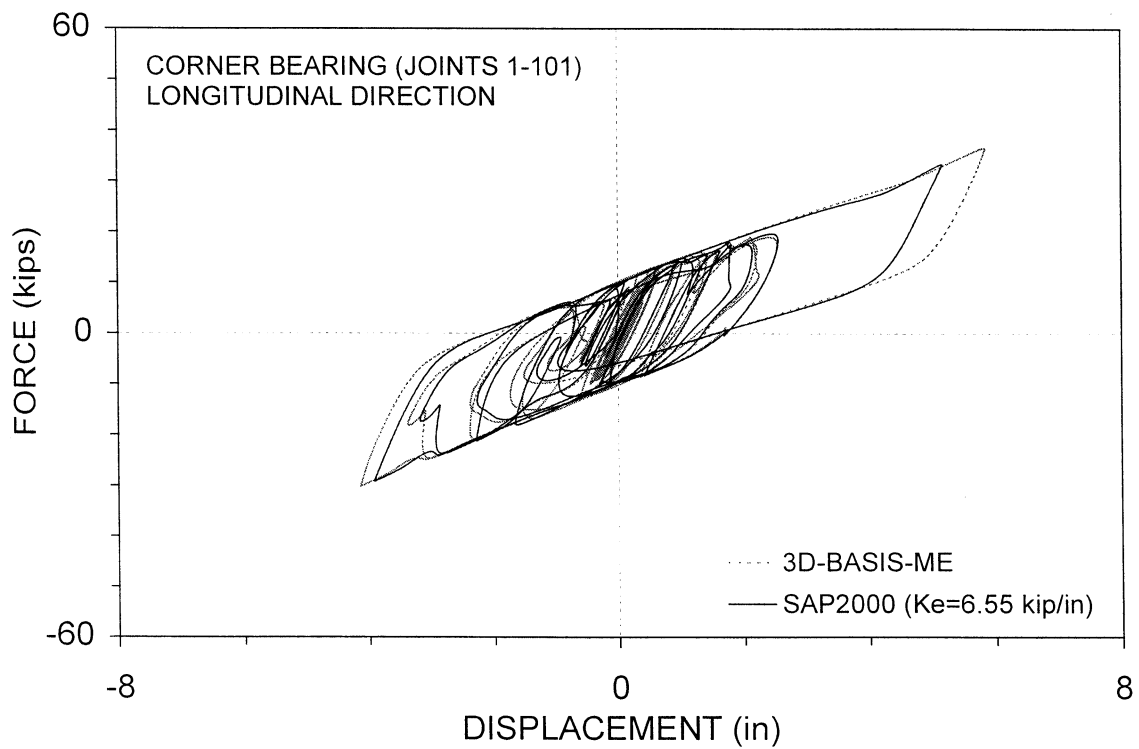
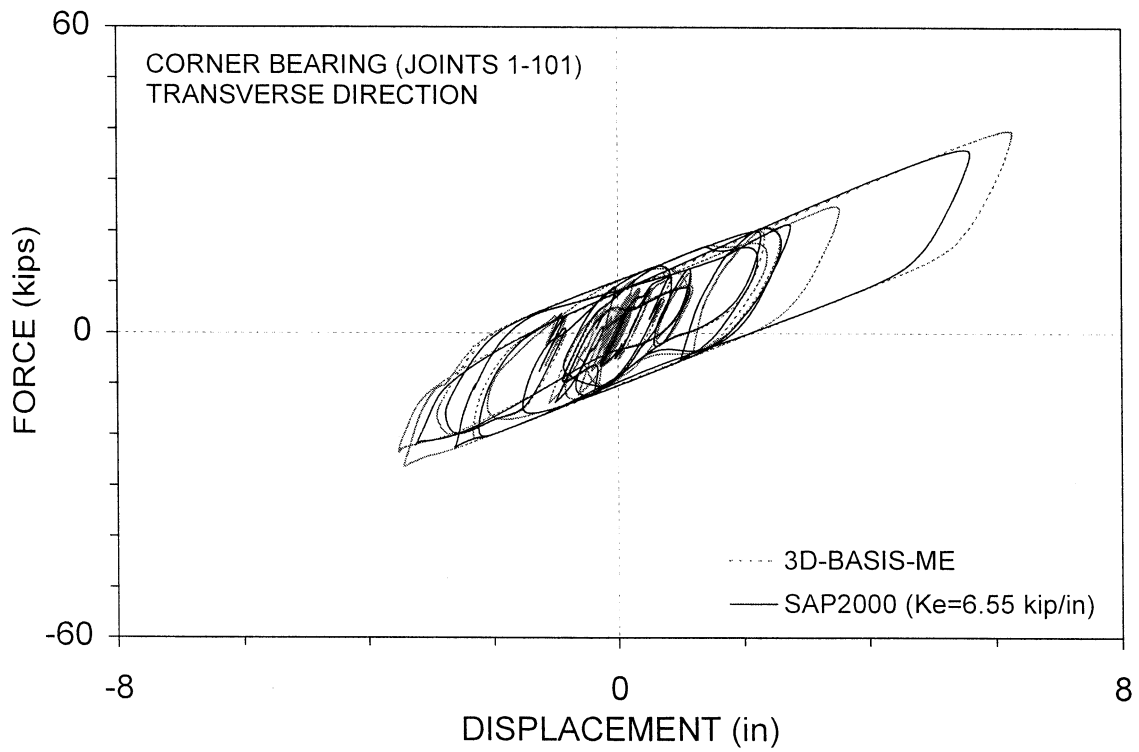


**Figure 2-8 Comparison of Calculated 3rd Floor Acceleration Histories**



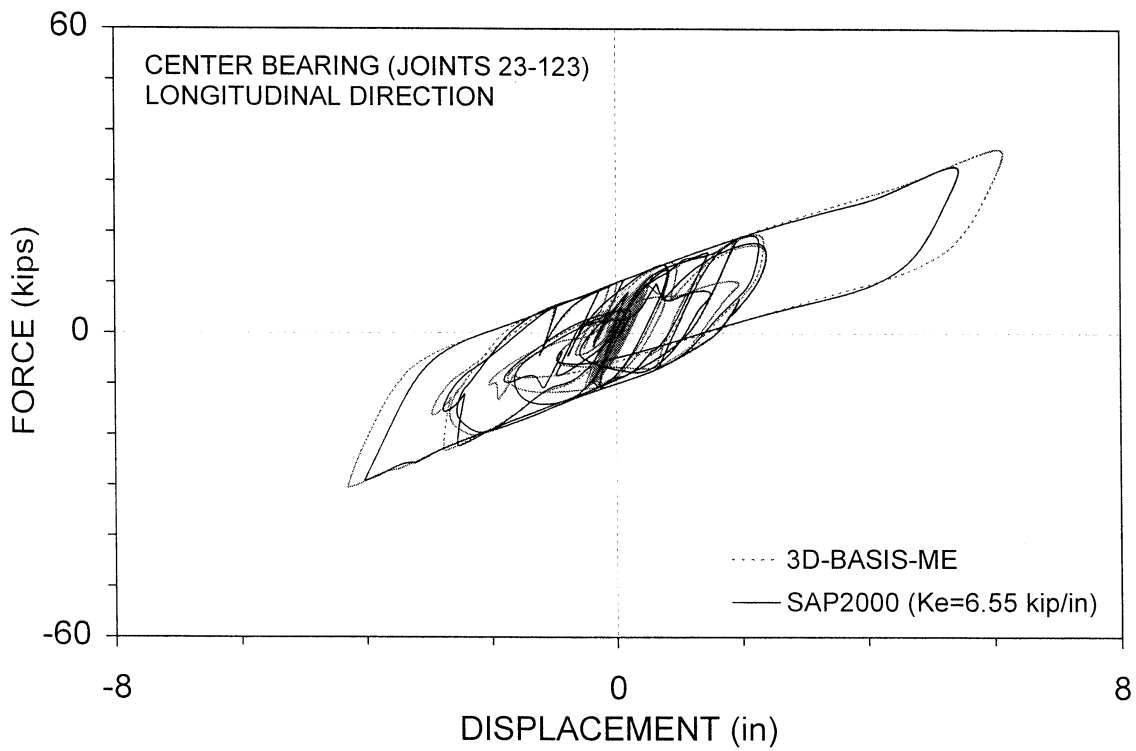
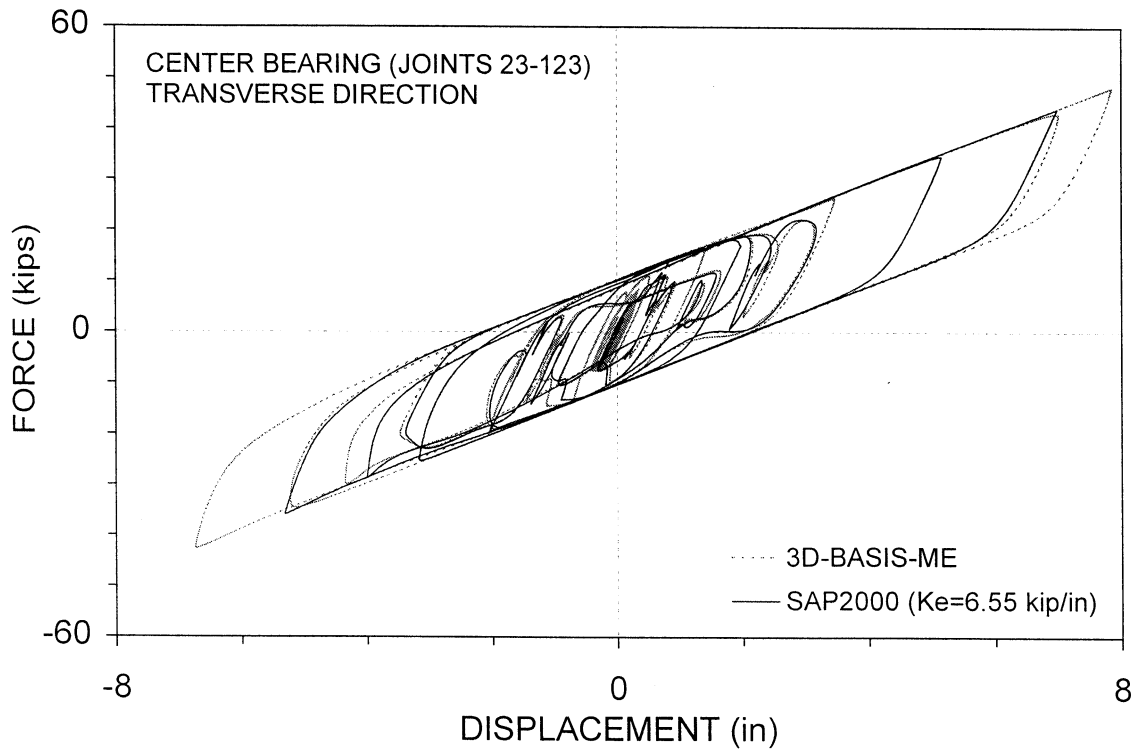
**Figure 2-9 Comparison of Calculated Relative Story Rotation Histories**

those of 3D-BASIS-ME. This is illustrated in Figures 2-10 and 2-11, which compare the calculated force-displacement loops of two bearings. The SAP2000 solution underestimates the bearing displacements, though the underestimation may not be of practical significance in this example. A likely explanation for this small discrepancy in the results of SAP2000 is that the modes for the actual value of the linear effective stiffness do not adequately represent the behavior of the analyzed system. It should be noted that the analytical prediction did not improve when Ritz vectors were used instead of mode shapes.



**Figure 2-10 Comparison of Calculated Force-Displacement Loops for Corner Bearing when the Actual Value of  $k_e$  is Used**





**Figure 2-11 Comparison of Calculated Force-Displacement Loops for Center Bearing when the Actual Value of ke is Used**



## SECTION 3

### ANALYSIS OF A LIQUID STORAGE TANK WITH THE FRICTION PENDULUM ISOLATION SYSTEM

#### 3.1 Introduction

The system analyzed in this section is a seismically isolated liquid storage tank. It is described and analyzed in the manual for 3D-BASIS-ME (Tsopelas et al., 1994). Neither 3D-BASIS-ME nor SAP2000 have the capability of explicitly modeling the dynamic behavior of a liquid storage tank, that is, to directly model fluid-structure interaction. However, both programs are capable of analyzing mechanical models of the liquid-tank system such as that described by Haroun and Housner (1981). In this approach, mathematical analysis is employed in order to arrive at a representation of the system consisting of an assemblage of oscillators, each one of which simulates a specific effect, such as sloshing of the liquid, deformation of the liquid-tank system and impulsive response. The calculated response of these oscillators is then used to evaluate important response quantities for design, such as base shear and bending moment induced by the hydrodynamic wall pressure, and vertical displacement of the liquid.

Program 3D-BASIS-ME has the capability of modeling multiple structural systems connected to a rigid basemat, above the seismic isolators. The program also has the options of including overturning moment effects through the use of an externally supplied function, and of vertical ground acceleration. Since vertical degrees-of-freedom are excluded in program 3D-BASIS-ME, the specified vertical ground acceleration is used to directly modify the instantaneous vertical load on the bearings. In most cases, for

example building structures, this is sufficient. However, liquid storage tanks are vertically flexible (i.e., axisymmetric mode of vibration), which typically results in additional axial load on the bearings. In this case, a modified vertical acceleration history must be specified, which is calculated by an independent analysis of the system in the vertical direction.

3D-BASIS-ME permits modeling of the horizontal dynamic response of seismically isolated liquid storage tanks, but considerable a priori knowledge of the behavior of such systems is required. The main feature of the program is the calculation of the instantaneous vertical load on the bearings and the incorporation of this effect on the instantaneous stiffness and friction force in the Friction Pendulum bearings.

Program SAP2000 has a three-dimensional formulation which, unlike program 3D-BASIS-ME, allows for direct consideration of the vertical ground acceleration and overturning moment effects. This option has not been fully exercised in this example. Rather, the changes in axial load due to the overturning moment have been ignored and vertical oscillations have been effectively suppressed, with the only maintained feature in the program being the effect of the vertical ground acceleration. That is, the model in SAP2000 has been reduced to one that can be directly modeled by 3D-BASIS-ME so that results from the two programs could be compared. Thus, this example primarily represents a verification test for the **Isolator2** property of the **Nlink** element of SAP2000 within a rather complex structural system with a small number of degrees of freedom.

Certain difficulties were encountered in the modeling of the mechanical representation of the liquid-tank system, which will be described later in this section. When these difficulties were effectively bypassed, SAP2000 produced results that were

nearly identical to those of program 3D-BASIS-ME.

### **3.2 Description of Analyzed Liquid Storage Tank**

The liquid storage tank is illustrated in Figure 3-1, whereas Figure 3-2 shows the layout of the isolation bearings. Material unit weights are: for water  $62.75 \text{ lb/ft}^3$ , for steel  $490 \text{ lb/ft}^3$  and for concrete  $150 \text{ lb/ft}^3$ . The weights are: water (for full tank) 28387.4 kips, steel tank 646.5 kips, steel roof 477.3 kips and concrete basemat 2629.8 kips with a total isolated weight of 32141 kips.

The liquid storage tank is represented by the mechanical system illustrated in Figure 3-3 on the basis of the theory of Haroun and Housner (1981). In this representation only the fundamental tank-fluid and liquid sloshing modes of vibration are considered, with the remaining modes considered to be rigid. It should be noted that each of the oscillators shown in Figure 3-3 has three degrees of freedom: two horizontal translational (UX and UY) with the properties indicated in the figure, and a rotational about the vertical axis of which the associated rotational stiffness and mass moment of inertia are arbitrarily specified to be very small and very large, respectively.

The isolation system consists of 52 identical Friction Pendulum bearings with a radius of curvature equal to 82.4 in. It is assumed that all 52 bearings are subjected to the same bearing pressure under static conditions. Even so, the frictional properties of the bearings cannot be identical due to variations in the vertical load that results from the vertical ground motion and the overturning moment. The frictional properties were assumed to be independent of the instantaneous pressure, with the coefficient of sliding friction described by

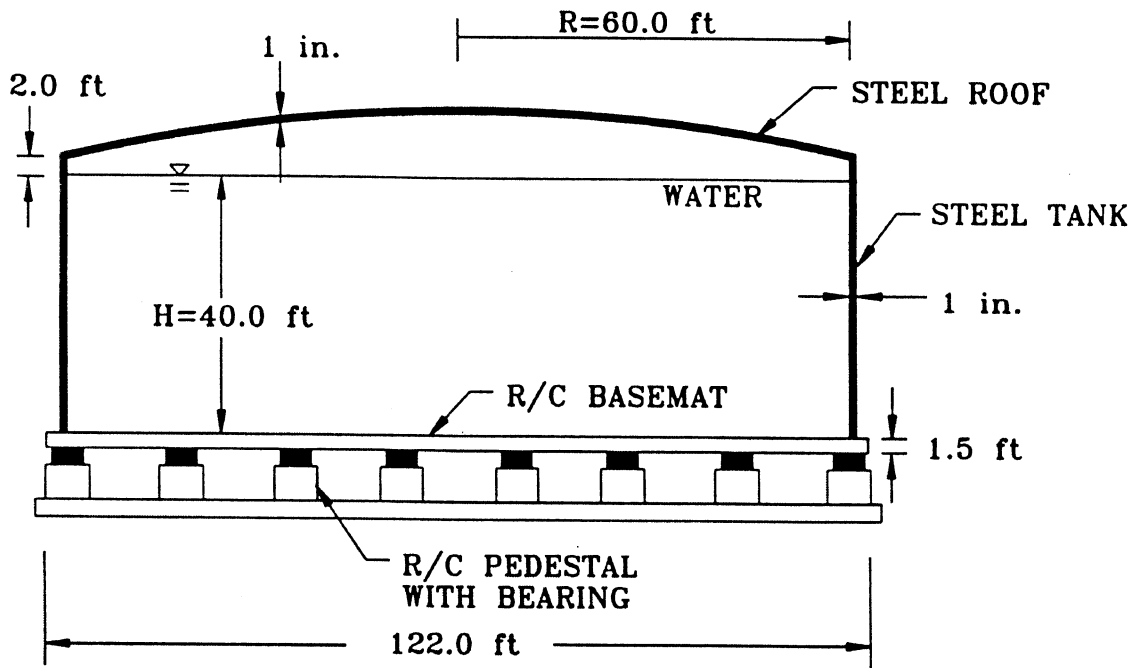


Figure 3-1 Geometry of Isolated Water Tank

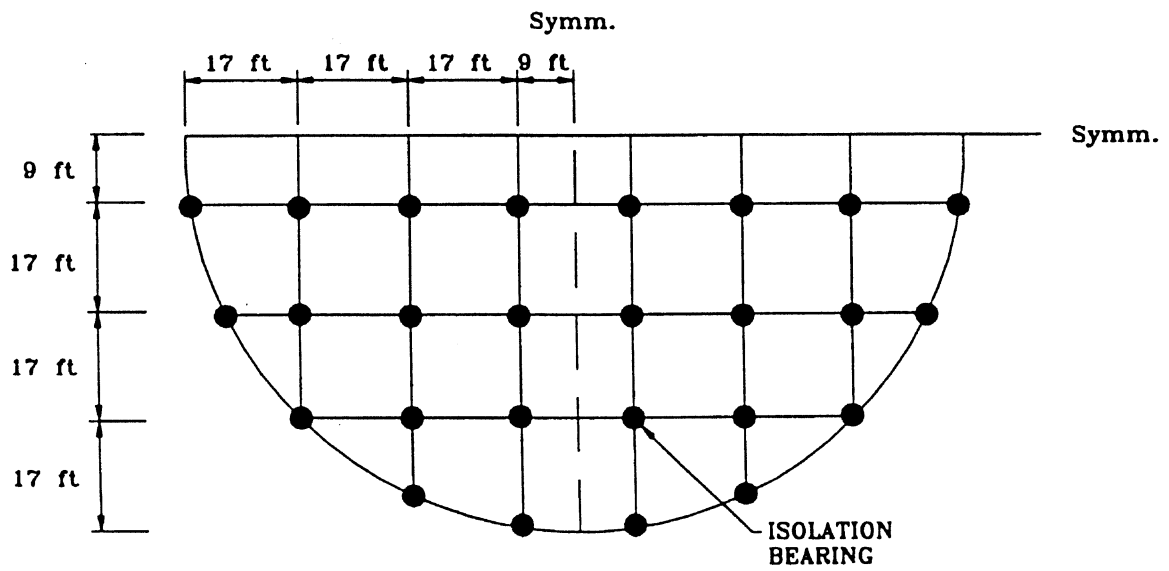


Figure 3-2 Configuration of Isolation System

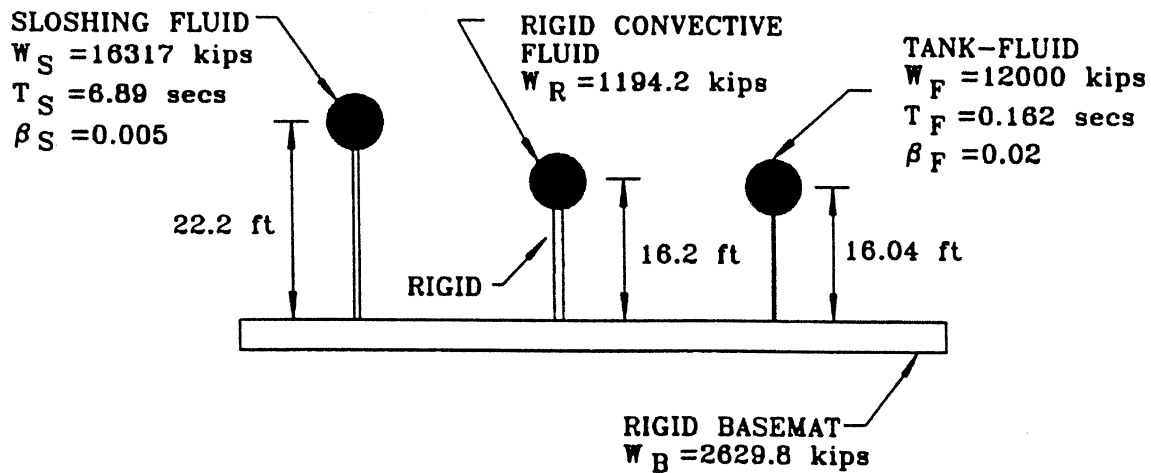


Figure 3-3 Mathematical Model of Liquid Storage Tank

$$\mu = f_{\max} - (f_{\max} - f_{\min}) \exp(-av) \quad (3-1)$$

where  $v$  = amplitude of instantaneous sliding velocity vector,  $a = 0.8 \text{ sec/in}$ ,  $f_{\max} = 0.045$  and  $f_{\min} = 0.03$ .

### 3.3 Modeling of Liquid Storage Tank in 3D-BASIS-ME

The model in 3D-BASIS-ME has been presented in Tsopelas et al. (1994). In this model the oscillators in Figure 3-3 are represented as single story, shear-type structures connected to the center of mass of the basemat which is located at its geometric center. That is, no eccentricities are considered. It should be noted that in the analysis of Tsopelas et al. (1994) an eccentricity of one-percent of the tank's plan dimension was considered.

The 52 bearings are represented by clusters of bearings as shown in Figures 3-4 and 3-5. The central cluster (No. 5) consists of 26 bearings, whereas the remaining

bearings are equally divided to four identical clusters. The clusters are located at specific locations so that the rotational stiffness of the five clusters is identical to that of the 52 bearings (on the basis of the horizontal stiffness, excluding friction).

The model analyzed herein is identical to that analyzed by Tsopelas et al. (1994), except that eccentricities are neglected, and the overturning moment effects and the dependency of the coefficient of friction on the instantaneous bearing pressure are not considered. Each cluster of bearings are assigned the following properties: radius 82.4 in,  $a = 0.8 \text{ sec/in}$ ,  $f_{\max} = 0.045$ ,  $f_{\min} = 0.03$  and gravity load of either 16070 kips (No. 5) or 4017 kips (No. 1 to 4). Moreover, a value for the yield displacement equal to 0.02 in. is used, based on the mechanical properties of the sliding interface.

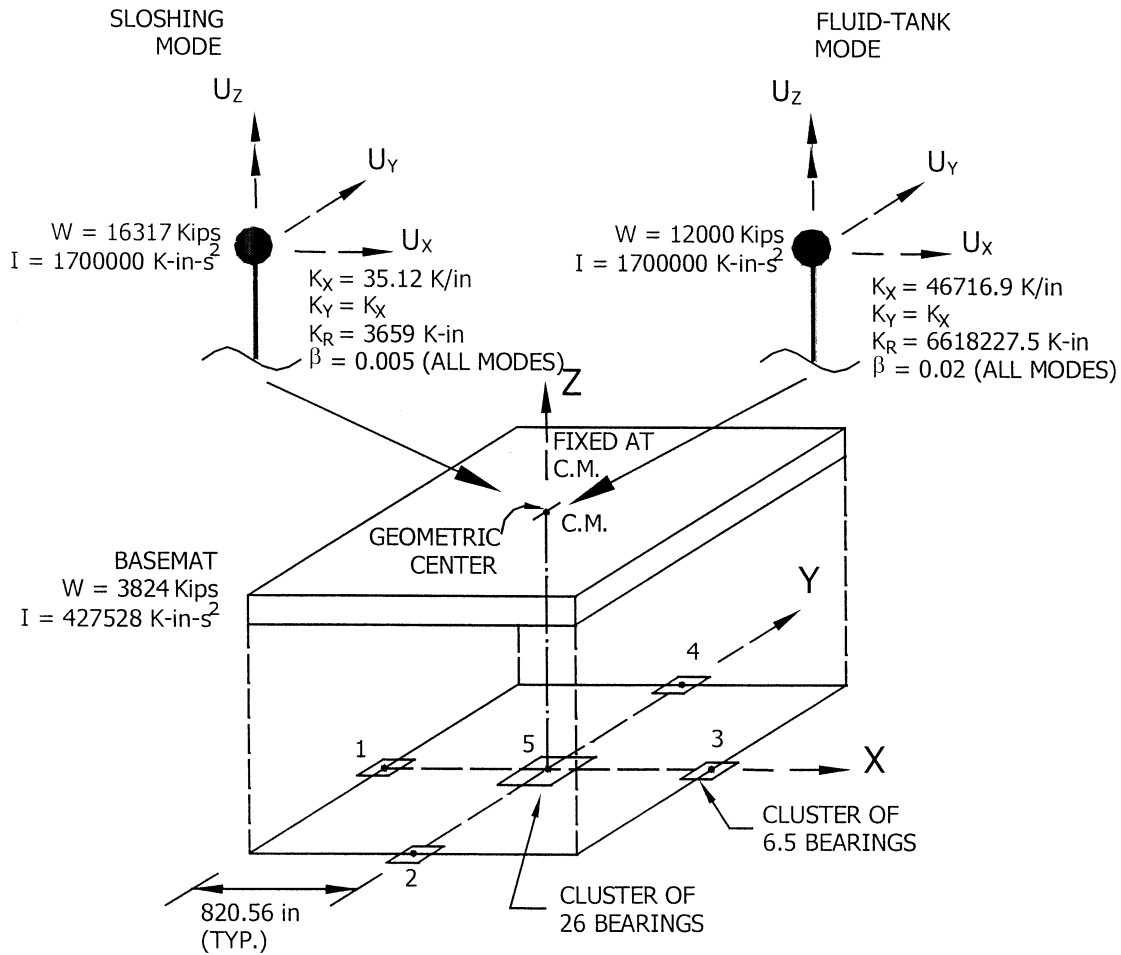
The seismic excitation consists of the Pacoima Dam record of the 1971 San Fernando earthquake. Component S16E (peak acceleration of 1.17g) is applied in the X direction and component S74W (peak acceleration of 1.08g) is applied in the Y direction. The vertical component has a peak acceleration of 0.71 g, resulting in a maximum  $\pm 71$ -percent variation in the axial load on the bearings (for the vertically rigid model). The excitation is a severe earthquake motion with high velocity, near-fault characteristics.

### **3.4 Modeling of Liquid Storage Tanks in SAP2000**

Modeling of the tank in SAP2000 was impeded by:

- (a) The requirement to model the system in a shear-type representation, that is, to exclude the vertical displacement degree of freedom. In general, this degree of freedom should be included. The use of **Nllink** element, **Isolator2** property for representing the Friction Pendulum bearings requires that this degree of freedom is

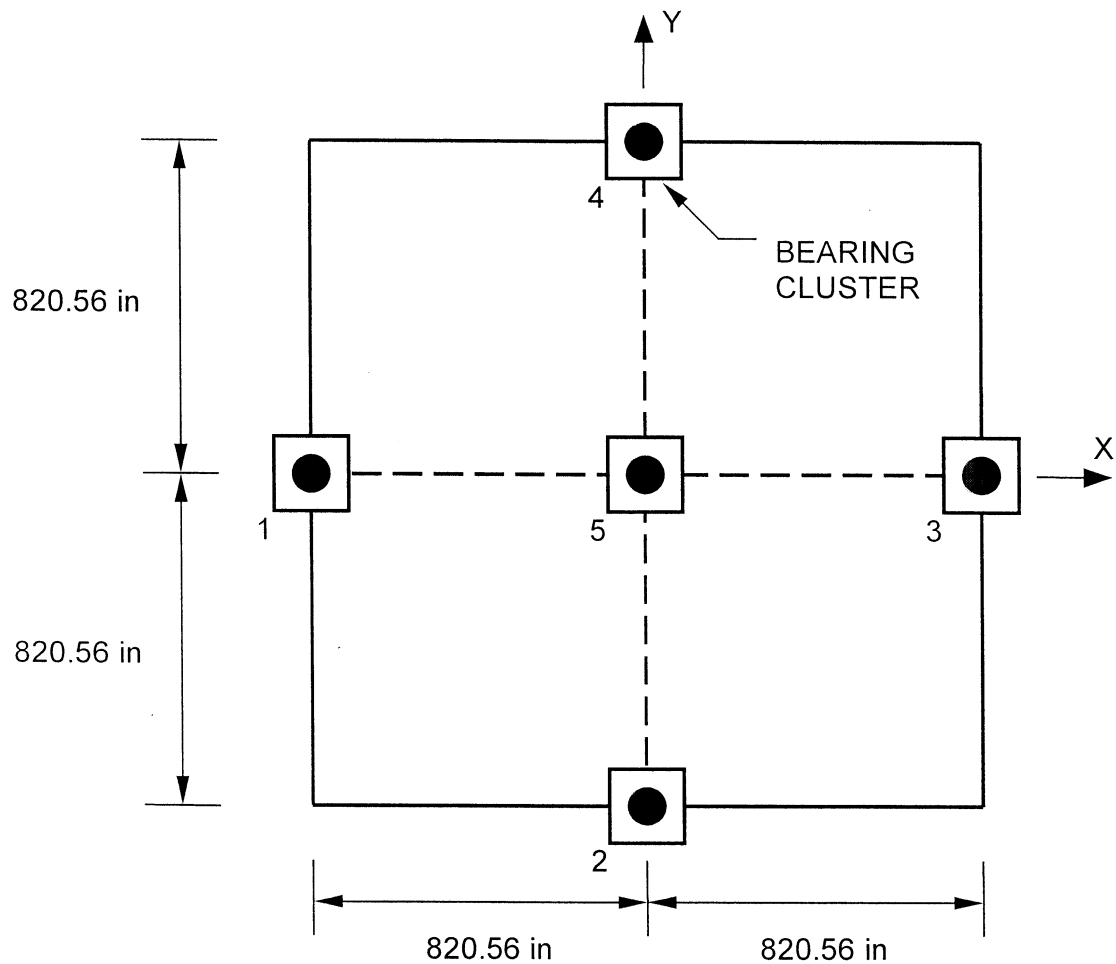




**Figure 3-4 Model of Liquid Storage Tank in 3D-BASIS-ME**

maintained. It was effectively suppressed by using damping elements.

- (b) The requirement to specify the damping ratio for each part of the superstructure, which is not possible to accurately accomplish through specification of global damping. For this case of simple one-story superstructures, the problem was circumvented by utilizing damping elements.



**Figure 3-5 Location of Clusters of Bearings in 3D-BASIS-ME**

The SAP2000 model consisted of the following elements:

- (a) **Nlink, plastic1** property elements to represent each of the two superstructures. Linear behavior of these elements was ensured by specifying a value of unity for **ratio** and a large value for **yield** (the yield force). The stiffnesses for the shear deformations and the rotational degree of freedom (which is linear) were specified in accordance with Figure 3-4. The vertical displacement degree of freedom was maintained but effectively suppressed by specifying a small vertical mass and a

related vertical stiffness that resulted in a large vertical frequency (=1000 rad/sec). The **linear effective stiffness ke** for each of the nonlinear elements was specified to be very small (**ke** = 0.0001 kip/in).

(b) **Nllink, damper** property elements to represent damping in the two superstructures.

The nonlinear configuration of this element was used with **cexp** being unity (default value). A very small value for the **linear effective stiffness** was used (= 0.0001 kip/in) and zero value (default) for the **linear effective damping** was used.

(c) **Nllink, Isolator2** property elements for the Friction Pendulum bearings. Each of the five clusters shown in Figure 3-5 was represented by an element with **radius** = 82.4 in, **rate** = 0.8 sec/in, **slow** = 0.03, **fast** = 0.045, **elastic stiffness ke** = 21092 kip/in or 84370 kip/in and **linear effective stiffness ke** = 0.0001 kip/in. The elastic stiffness was determined from

$$K = \frac{f_{\min} W}{Y} \quad (3-2)$$

where  $W$  = gravity load on the bearing cluster,  $f_{\min}$  = minimum value of the coefficient of friction (= 0.03) and  $Y$  = yield displacement (= 0.02 in). The value of the linear effective stiffness was specified very small based on experience gained in the analysis of the 8-story isolated structure (see Section 2).

The gravity load on the bearings is typically generated in SAP2000 from loads applied to the superstructure. In this case the gravity load was specified as concentrated **force load** directly on the bearings. These forces were applied quasi-statically, that is, dynamically over a long time duration. The program's built-in ramp function was used with a duration of 10 sec (5 sec build-up time and 5 sec constant load) and with a large modal damping ratio (= 0.99) to prevent oscillations.

(d) **Nlink, damper** property for suppressing vertical oscillations in the elements representing the clusters of Friction Pendulum bearings. A large value of **stiffness k** was used to simulate pure damping behavior. However, the **linear effective stiffness ke** was again specified very small to avoid errors. The element was used in its nonlinear option but with **cexp** = 1. When the linear option was used the element was null (that is, it produced no effect).

An appropriate value for the **damping coefficient c** was determined by trial and error. The values of this coefficient, of the axial stiffness of the Friction Pendulum bearings and of the step for time-history analysis were varied so that the calculated axial force on the Friction Pendulum bearings was essentially equal to the gravity load multiplied by  $\ddot{u}_v / g$ , where  $\ddot{u}_v$  = vertical ground acceleration.

That is, vertical oscillation at isolation system level was effectively eliminated and the overturning moment effects were suppressed. The attempt to eliminate vertical oscillations and overturning moment effects was made so that the results could be compared to those of program 3D-BASIS-ME. In general, these effects should be accounted for in the analysis.

The selection of elements used in the modeling of the liquid storage tank is not unique; other combinations of elements or options could have been utilized. A number of these options were investigated and found unsuccessful. Specifically:

- (a) When the linear option for the **Nlink, damper** property elements was used, the analysis could not be performed when **ke** was specified to have a large value, whereas the element was null when the value of **ke** was specified to be very small.
- (b) When the **Nlink, damper** property element was used instead of the **plastic1** property

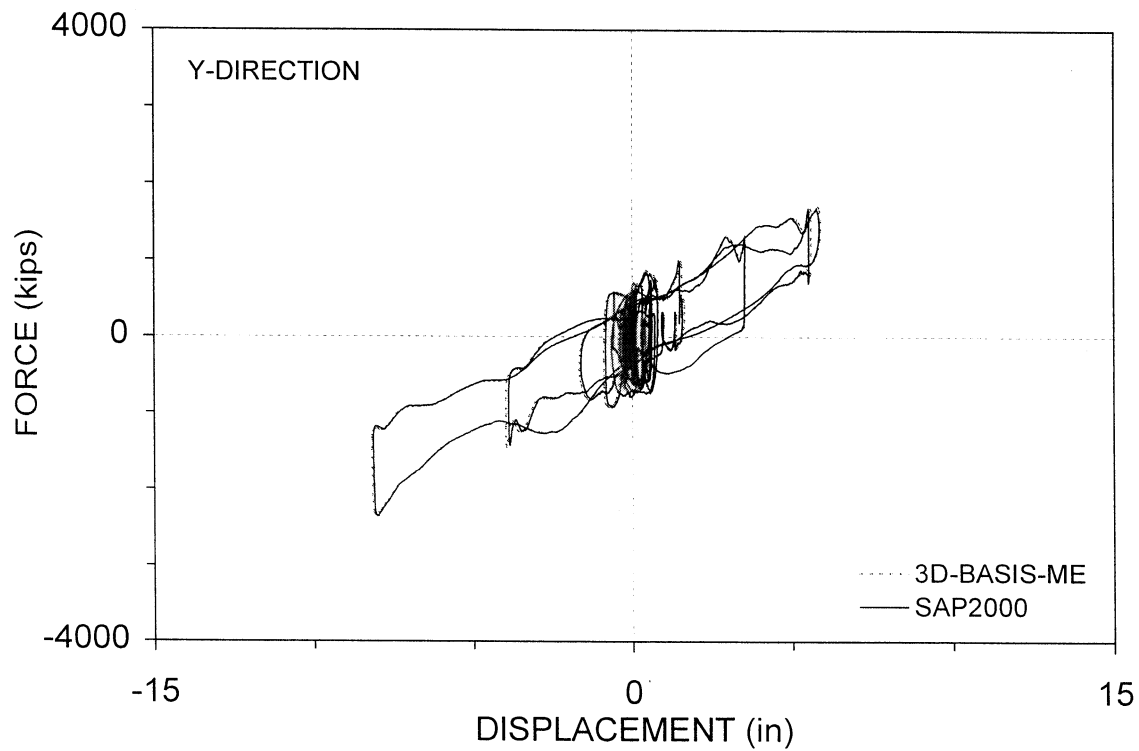
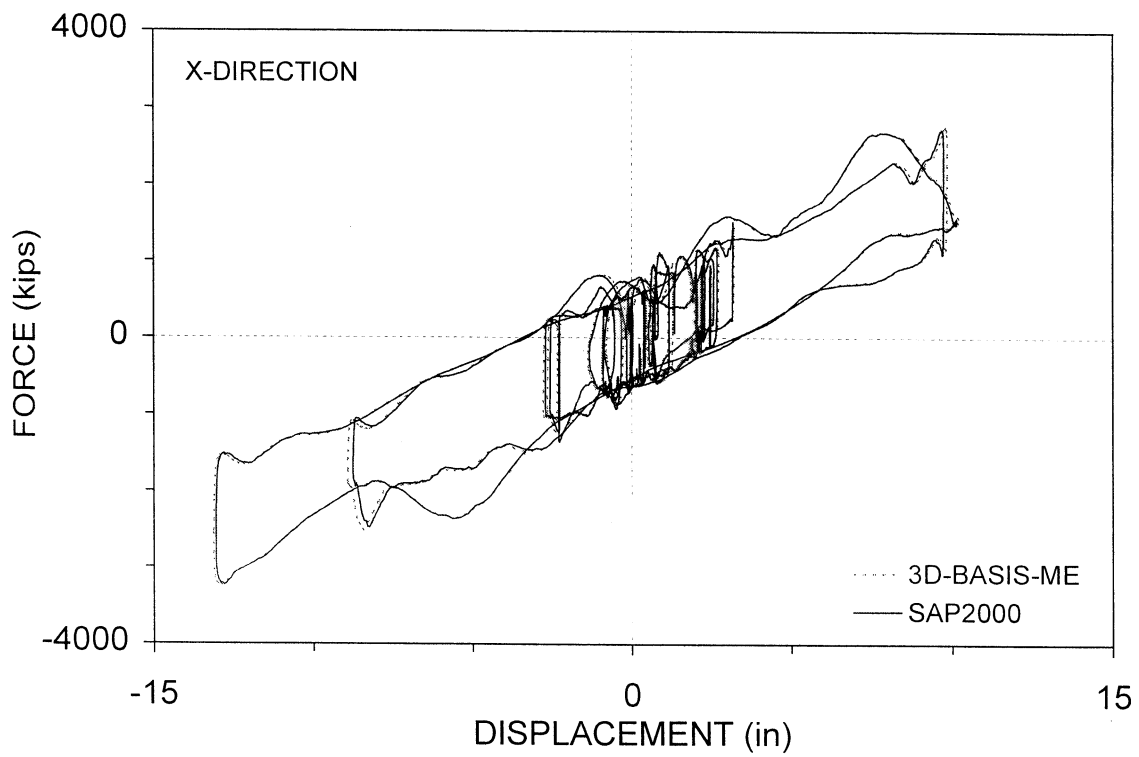
for representing the stiffness of the superstructures (as it was done in the 8-story building example), the analysis could not be performed. Only when the element was used in its nonlinear option with very small **ke** analysis could be performed. However, the results were obviously erroneous.

### **3.5 Comparison of Results**

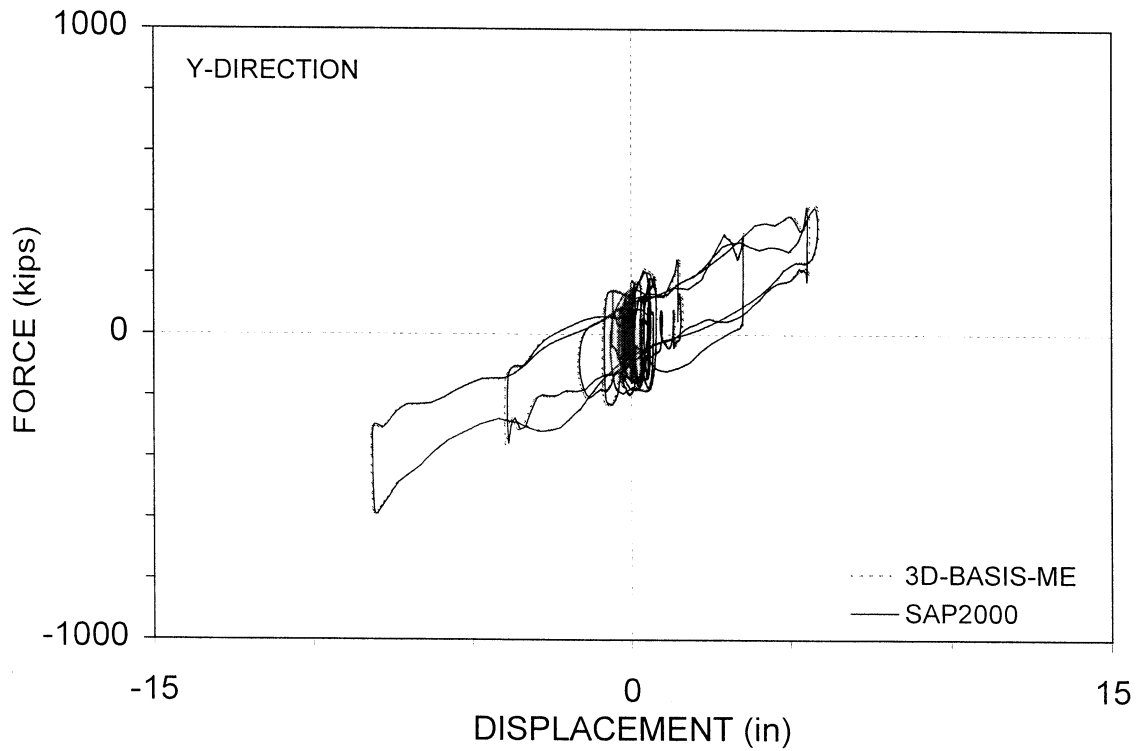
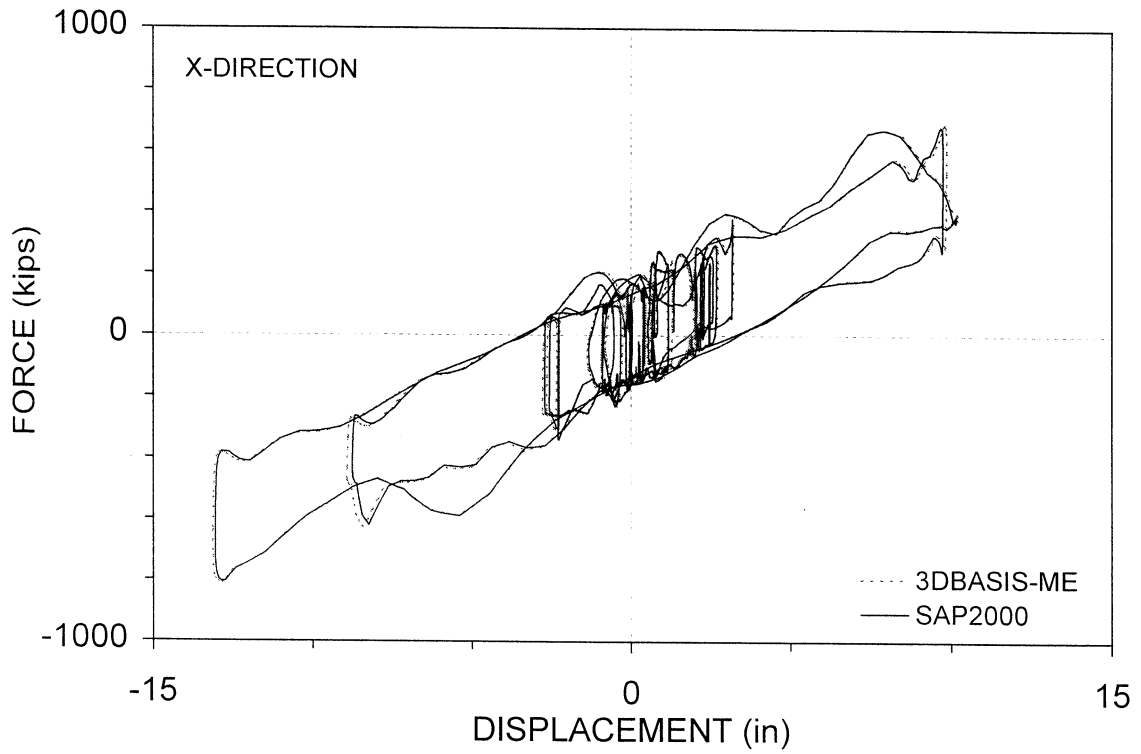
Figures 3-6 and 3-7 compare the calculated force-displacement loops of the central and for one of the exterior clusters of bearings. The results of the two programs are nearly identical.

Figures 3-8 to 3-11 compare the calculated histories of displacements and accelerations of the sloshing fluid and the fluid-tank mode. Some insignificant differences are observed in the results for the fluid-tank mode. It should be noted that this mode is substantially stiffer (period of 0.162 sec) than either the sloshing fluid mode or the isolation system. These differences are due to the modeling used in the two programs and in the numerical integration algorithms.

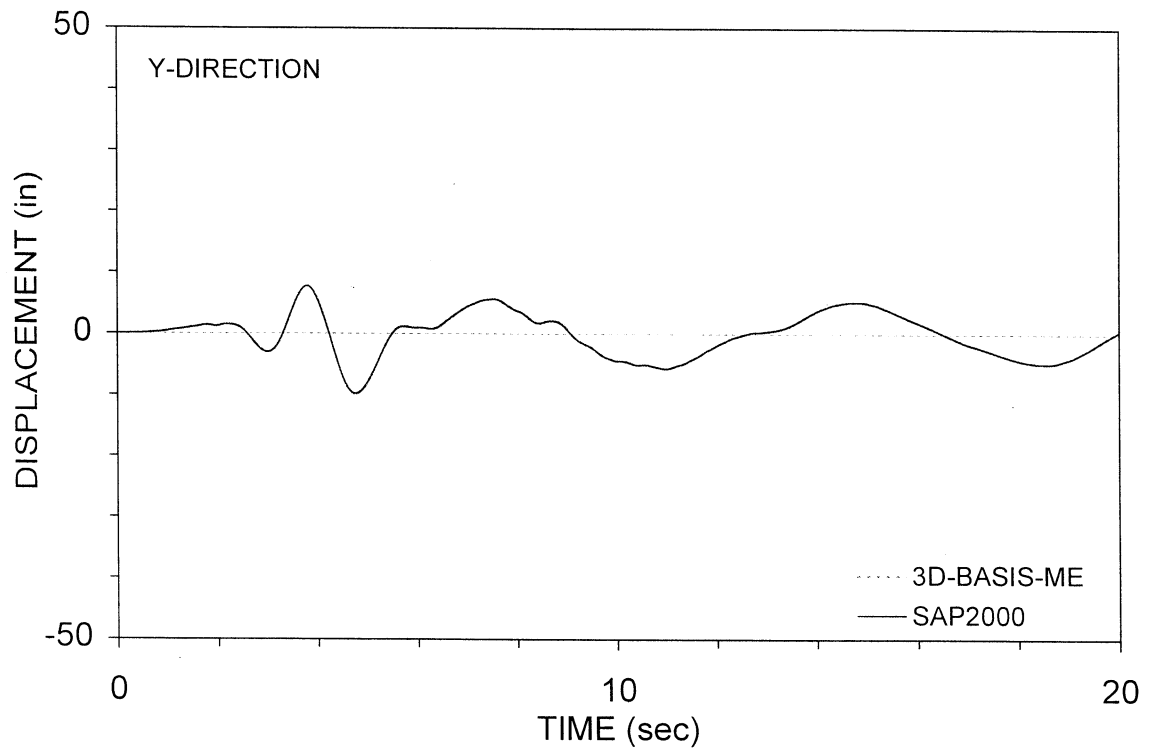
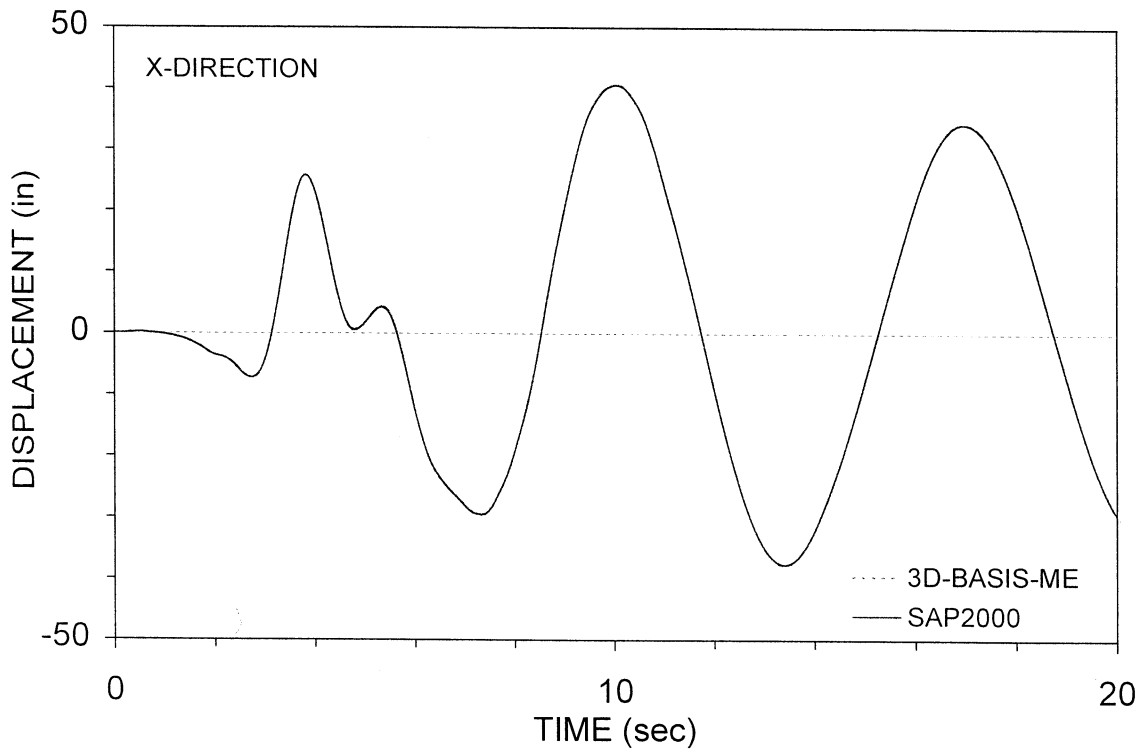
Of particular interest is the calculated acceleration history for the fluid-tank mode. The peak acceleration value is used in the calculation of the overturning moment and shear force for the design of the tank. The two programs predict nearly identical peak values (see Figure 3-11). Moreover, the calculated acceleration histories may be used to construct response spectra for pipework analysis and design (that is, construction of "floor" response spectra). The calculated acceleration histories have different frequency contents, with the SAP2000 results exhibiting slightly higher frequency content. Such differences would inevitably result in differences in the "floor" spectra, which may be



**Figure 3-6 Comparison of Calculated Force-Displacement Loops for Central Cluster of Bearings (No. 5)**

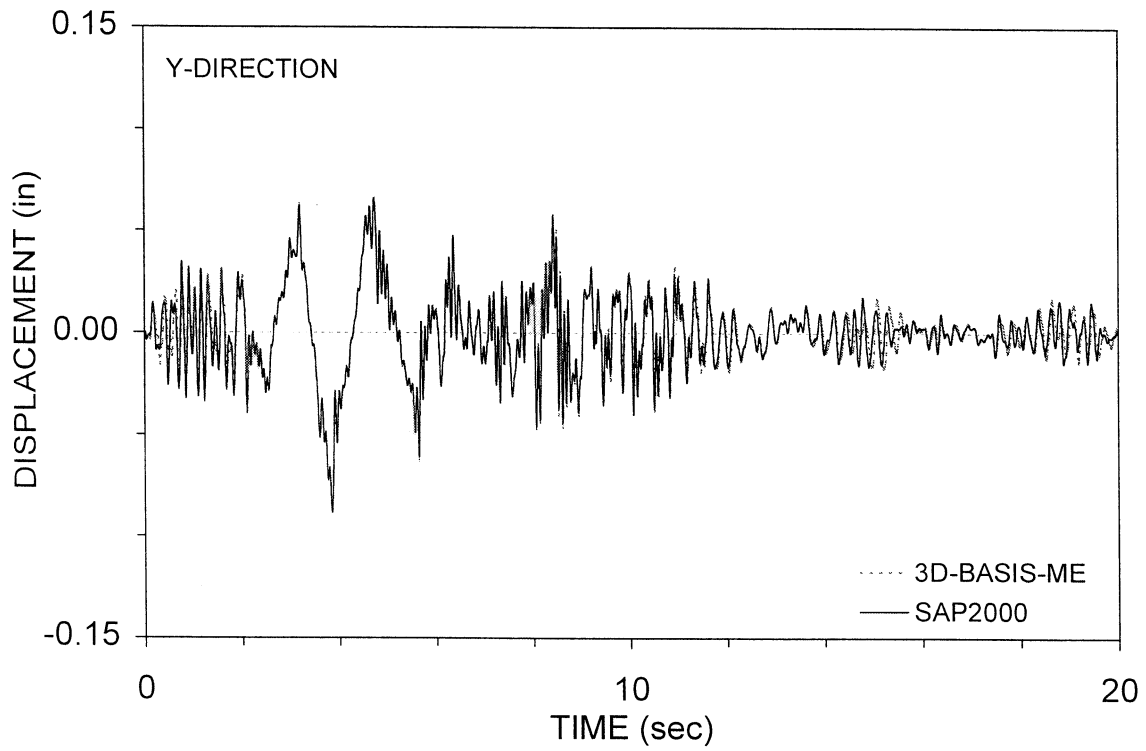
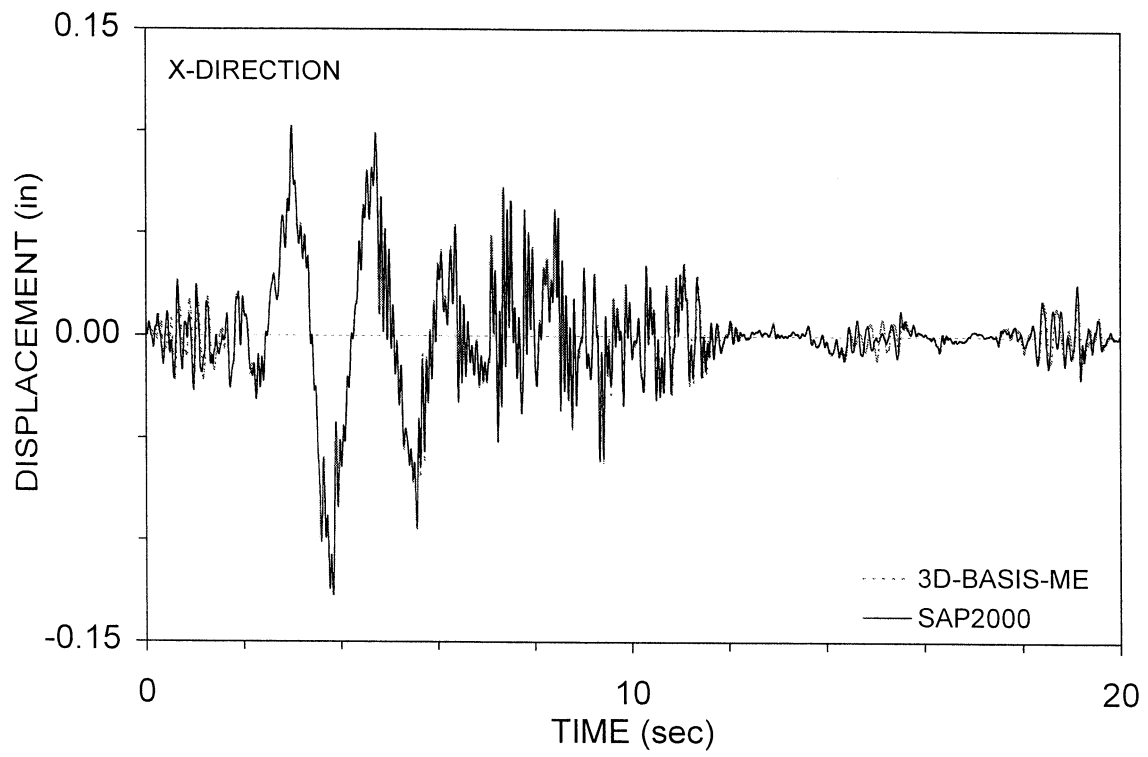


**Figure 3-7 Comparison of Calculated Force-Displacement Loops for Exterior Cluster of Bearings (No. 1)**

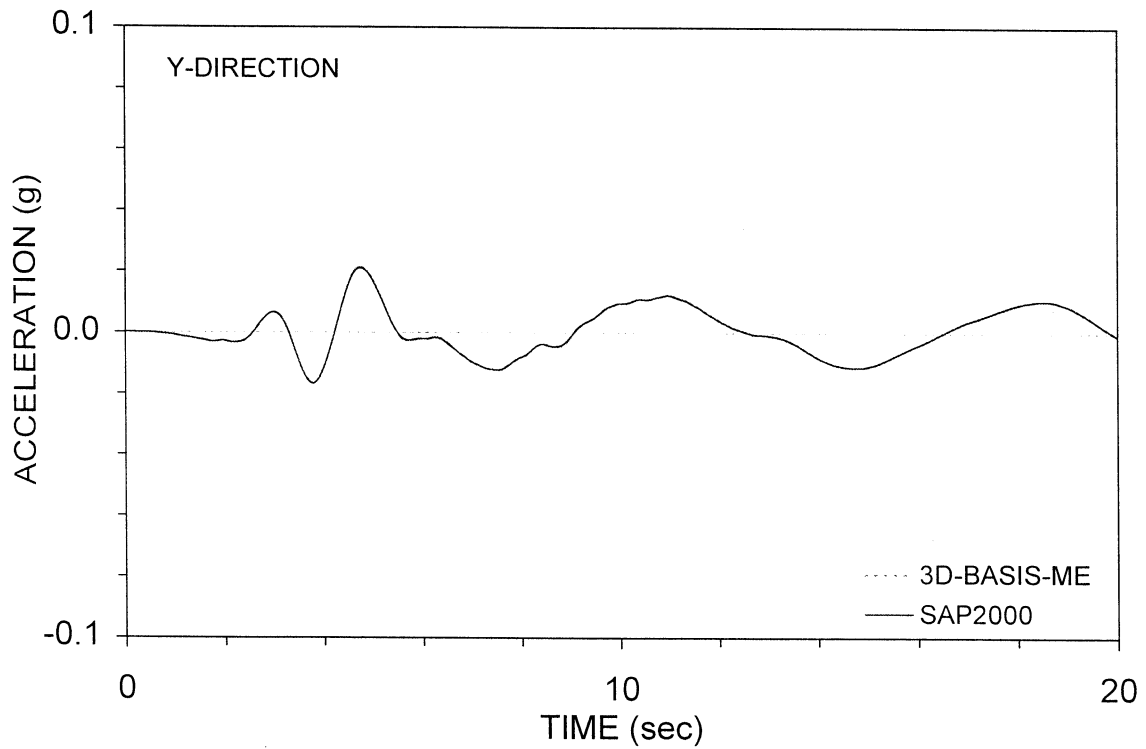
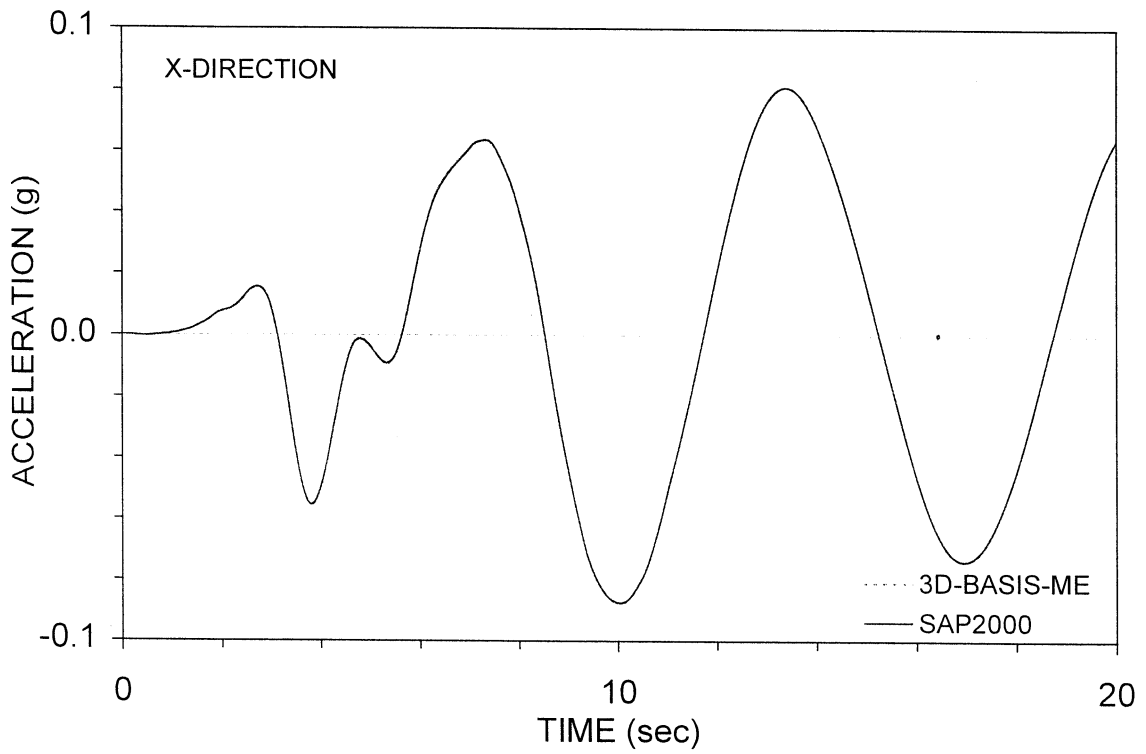


**Figure 3-8 Comparison of Calculated Displacements of Sloshing Fluid**

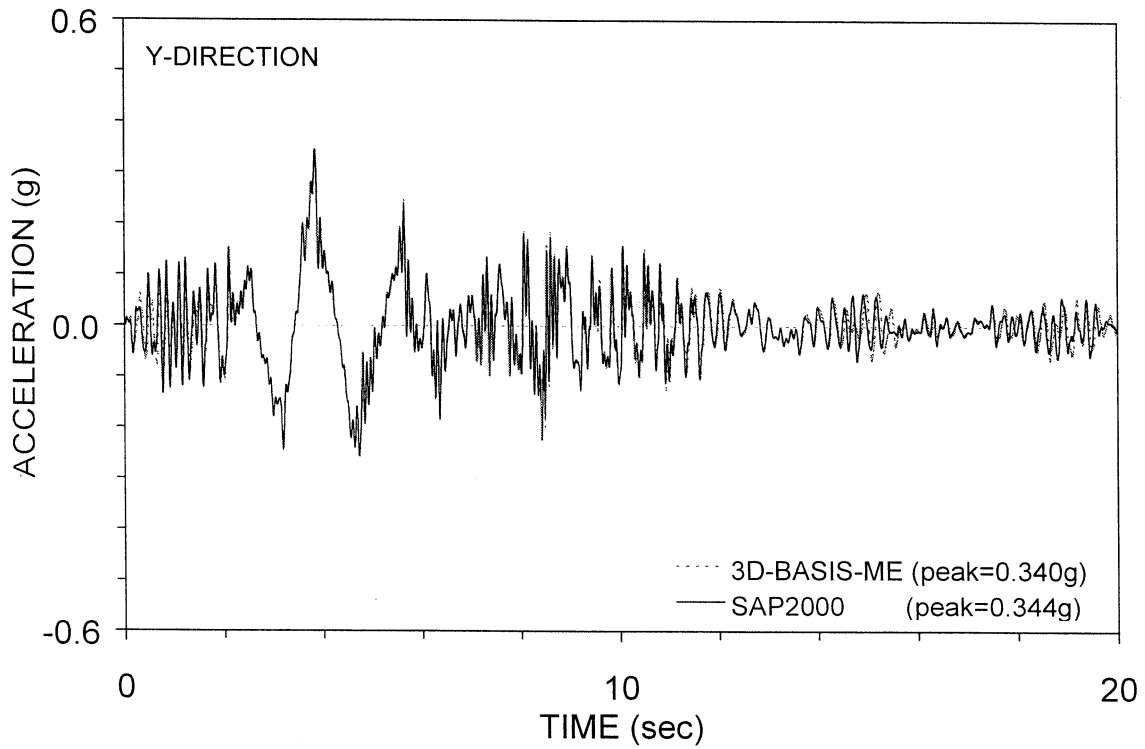
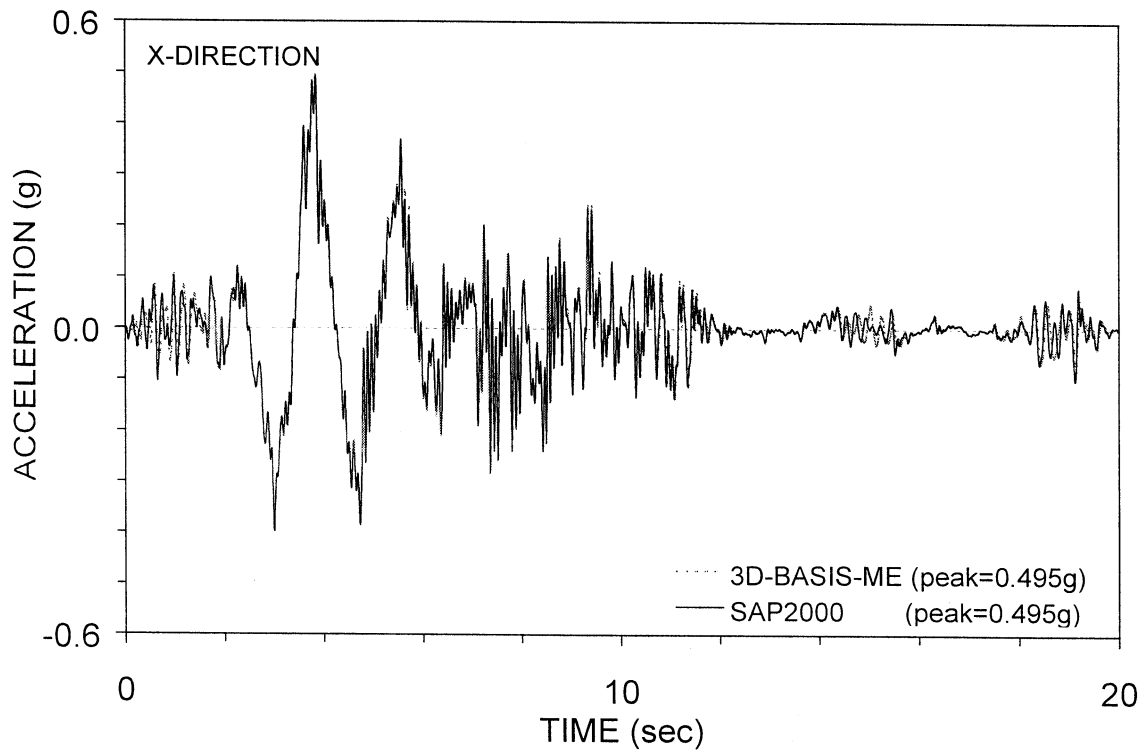




**Figure 3-9 Comparison of Calculated Displacements of Fluid-Tank Mode**



**Figure 3-10 Comparison of Calculated Accelerations of Sloshing Fluid**



**Figure 3-11 Comparison of Calculated Accelerations of Fluid-Tank Mode**

substantial. Experience has shown that the high frequency end of such spectra is unrealistic and typically traceable to some seemingly insignificant parameter in the model, such as the "yield displacement" or the elastic shear stiffness, in programs 3D-BASIS-ME and SAP2000, respectively. A notable example of such experience has been the analysis of two LNG storage tanks described by Constantinou (1998b). It is appropriate to state at this time that there is no analysis program that can produce reliable results for the high frequency end of "floor" response spectra.

## SECTION 4

### ANALYSIS OF EXPERIMENTAL RESPONSE OF A 7-STORY BUILDING MODEL WITH FRICTION PENDULUM ISOLATION SYSTEM

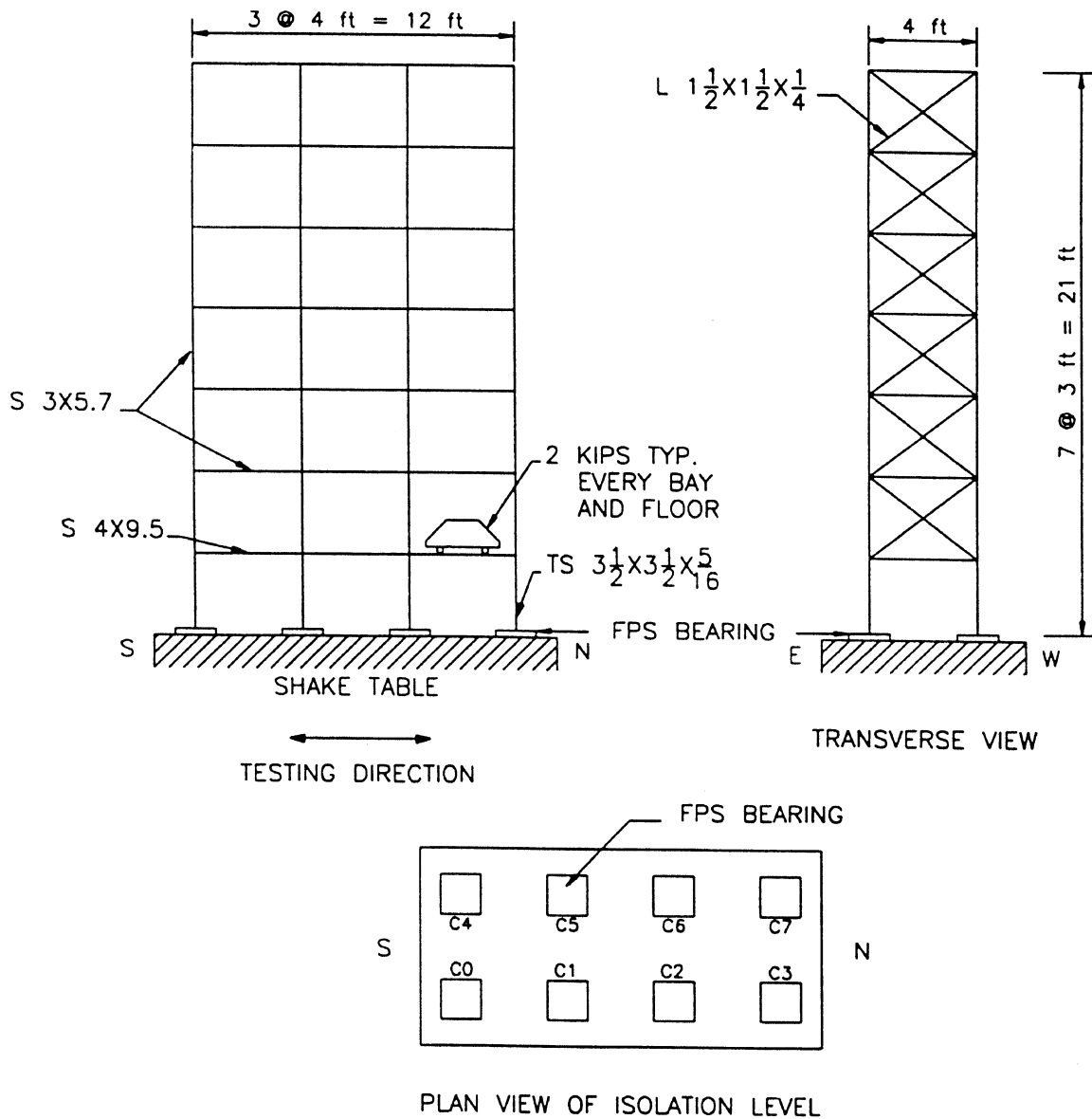
#### 4.1 Introduction

The structure analyzed in this section is a 7-story seismically isolated building model that was tested on a shake table by Al-Hussaini et al. (1994). This model was tested in a variety of configurations, one of which involved the isolators placed directly below each column of the moment frame, without an isolation basemat or diaphragm. Due to the large height-to-width ratio of the structure, large overturning moments developed in the experimental program which led to bearing uplift.

In this example, the modeling capabilities of SAP2000 are fully explored. Unlike the previous two examples in Sections 2 and 3, in which a specific behavior of the analyzed systems was sought (e.g., shear type representation, exclusion of overturning moment effects, etc.), the structural system is modeled in its entirety.

#### 4.2 Description of Tested Structure

Figure 4-1 shows elevations and a plan view of the 7-story model in one of the tested configurations. This configuration is termed MFUIS in the report of Al-Hussaini et al. (1994). This structure is a quarter length scale model of a slice of a building along its longitudinal direction. Connections of beams to columns are rigid, either welded or



**Figure 4-1 Elevations and Plan View of Tested Structure**

bolted depending on the location. The braces in the transverse direction are bolted with a single bolt at each end, that is, they are effectively pin-connected.

Concrete block and steel plate weights were installed at each floor and bay of the model for an estimated total weight of 47.5 kips. The distribution of this weight was estimated to be 7.6 kips at the first floor, 6.7 kips at the second to sixth floors, and 6.5

kips at the top floor. This weight includes the added block and steel plate weights and the tributary column, beam and brace weights.

The isolation system consisted of eight Friction Pendulum bearings, each with a radius of curvature equal to 9.75 in, directly connected to the square tube columns of the first story. Each bearing had a displacement capacity of 2 in. The contact area at the sliding interface of the eight bearings was such that the bearing pressure was about 18 ksi under the gravity load and on the basis of the assumption that load is distributed in accordance with the tributary area of each column (that is, exterior bearings carry 3.96 kips each, and interior bearings carry 7.92 kips each).

The exact distribution of gravity load on the bearings was not known due to the method used to erect the model on the shake table. In this method the bearings are first installed and leveled on the shake table, and then the model, fully loaded with weights and appropriately braced for lifting, is placed on top of the bearings. The distribution of load on the bearings is not exactly the one obtained when the structure is built from the bottom up, as in regular construction. Rather, the distribution deviates as a result of misalignments in the model.

The coefficient of sliding friction of individual bearings was not determined. Rather, the frictional properties were obtained for the entire assembly of the eight bearings. The coefficient of friction could be described by (3-1) with  $f_{\max} = 0.06$ ,  $f_{\min} = 0.04$  and  $a = 1.09$  sec/in. These properties are representative of the bearings for the average conditions of bearing pressure, that is, about 18 ksi. Given that in some of the tests the bearings experienced significant variations in bearing pressure, the analysis should have accounted for the effects of instantaneous pressure on the frictional

properties. This capability is not available in SAP2000, but it does not appear to have a significant effect on the calculated response.

Testing of this model was conducted with several earthquake motions applied in the longitudinal direction. Results presented herein and compared to the analysis results are for the S00E component of the 1940 El Centro earthquake record scaled up to a peak acceleration of 0.57 g (that is, twice the recorded level). In the testing and analysis, the time scale of the record was compressed by a factor of two in order to satisfy the similitude requirements.

### **4.3 Modeling in SAP2000**

The structure was modeled as a two-dimensional frame with the geometric properties of sections doubled to represent the full model. Figure 4-2 illustrates the model. **Frame** elements were used together with specified **offset** and **rigid-end factor** values. The four joints on each of the seven floors were constrained using the **diaphragm** option. Masses were lumped at the joints. The gravity load was directly developed at the top joint of bearing elements and applied dynamically using a ramp of 5 sec build-up time, followed by a 5 sec constant load interval, and a damping ratio of 0.99 in order to prevent oscillations. The applied gravity loads were 7.92 kips and 15.83 kips for the exterior and interior bearings, respectively. They were directly applied at the bearing top joints. In reality, the gravity loads on the bearings may have been different for the reasons explained in Section 4.2.



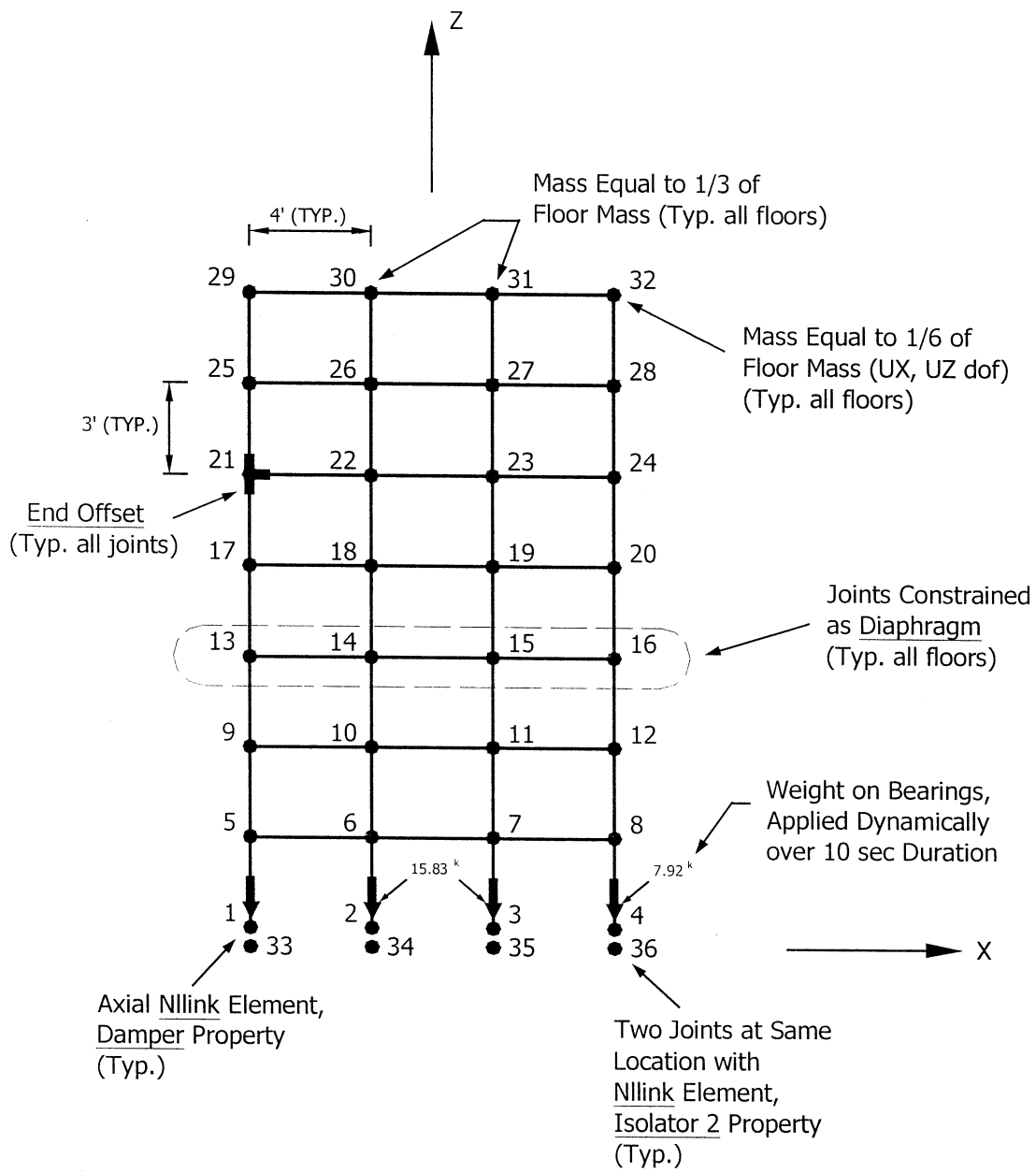


Figure 4-2 Model of 7-story Isolated Structure in SAP2000

The four Friction Pendulum bearings were modeled using the **Nlink** element, **Isolator2** property with the following parameters for the shear deformation degree of freedom:

- (a) **Elastic stiffness  $k$**  = 31.67 kip/in (exterior) and 63.33 kip/in (interior). This stiffness was calculated on the basis of (3-2) with  $f_{\min} = 0.04$ ,  $W$  = gravity load (7.92 kips or 15.83 kips) and  $Y = 0.01$  in.
- (b) **Linear effective stiffness  $k_e$**  = 0.0001 kip/in. This value was chosen on the basis of observations made in the first presented example (see Section 2.1). However, nearly identical results were obtained when realistic values of the linear effective stiffness were used. Specifically, values of  **$k_e$**  equal to 2.1 kip/in and 1.05 kip/in, for interior and exterior bearings respectively, were used.
- (c) **Radius** = 9.75 in, **fast** = 0.06, **slow** = 0.04, **rate** = 1.09 sec/in.

Moreover, the stiffness for the linear rotational degree of freedom was specified as  **$k_e$**  = 10,000 kip-in/rad, and the axial stiffness  **$k_1$**  was specified to be 20,000 kip/in. The latter figure was based on calculations of the stiffness using the actual geometry of the bearings.

The axial (vertical) degree of freedom of the **Nlink** element, **Isolator2** property is nonlinear. Accordingly, the axial linear effective stiffness  **$k_e$**  needs to be specified. An appropriate value is equal to  **$k_1$** , that is 20,000 kip/in. When such a value was used, execution of the program was aborted. When lower values were used, analysis was performed but the results were erroneous. Only when  **$k_e$**  was specified to be very small, has the analysis executed without problems and with good results.

Damping elements were added at the bearing locations in the vertical direction using the **Nlink** element, **damper** property with stiffness  $k = 10,000$  kip/in and damping coefficient  $c = 5$  kip-sec/in (to represent a pure linear viscous element). The value of the damping coefficient was selected to provide a damping ratio of 0.10 on the basis of a weight of 47.5 kips and total vertical bearing stiffness of 80,000 kip/in ( $4k_1$ ). That is,

$$\beta = (4c)/2\sqrt{(4k_1)(W/g)} .$$

Of interest is to explain the need for using vertical damping elements at the Friction Pendulum bearing locations. In general, such elements appear unnecessary and are not used in an example provided in the verification manual of SAP2000. When such elements were excluded, erroneous response was calculated. Specifically, the calculated bearing forces exhibited significant fluctuations. Some improvement was noticed when Ritz vectors were used rather than mode shapes. This issue will be revisited when analysis results are presented.

Global damping in the model was specified in terms of damping ratios for the eleven modes retained in the analysis. These values were obtained from experiments as described in Al-Hussaini et al. (1994) for the seven modes related to primarily horizontal movement, whereas the remaining modes (associated with primarily vertical movement) were assigned similar values.

At first, eigenvalue analyses were performed on the model with the elements representing the bearings removed and replaced by pins and rotational springs of stiffness equal to 10,000 kip-in/rad. This approximately represented the structure as tested in its non-isolated configuration. Parameter **rigid-end factor** was varied with a value of 0.45 finally resulting in mode shapes and periods that sufficiently approximated the

experimental values. Table 4-1 compares the experimental periods and mode shapes (only six were identified; all associated with horizontal floor displacement degrees of freedom) with the ones calculated by SAP2000. This indicates that SAP2000 sufficiently modeled the behavior of test structure in its non-isolated configuration.

#### **4.4 Analysis Results and Comparison to Experiment**

Figure 4-3 presents experimental and analytical results on the base shear-isolation-system displacement loops and the displacement history of isolators and the first story columns. The isolation system displacement is the displacement of the first floor with respect to the ground (that is, the bearing displacement plus the drift in the column). The base shear is the sum of the shear forces in the first story columns. In the experiment they were directly measured by strain gage load cells in each column. Moreover, the experimental displacement is the average of the recorded displacements at the two columns of the first floor level (east and west locations).

Figures 4-4 and 4-5 compare experimental and analytical histories of selected story drift, story shear and floor acceleration. The second story shear was determined from the recorded acceleration histories and the known distribution of mass. The third story drift was directly measured by displacement transducers placed on the east-side columns. The seventh floor acceleration was calculated as the average of recorded accelerations at the seventh floor on the east and west sides of the model.

These figures demonstrate that SAP2000 predicts well the experimental global response of the isolated structure, except for the prediction of higher shear force in the second story. It is possible that in this case the experimental shear force contains some

**Table 4-1 Experimental and Analytical Modal Properties of Non-isolated 7-story Model**

PERIOD (sec)

MODE	EXPERIMENTAL	SAP2000
1	0.455	0.458
2	0.139	0.151
3	0.081	0.088
4	0.052	0.061
5	0.041	0.045
6	Not identified (vertical)	0.039
7	0.034	0.036

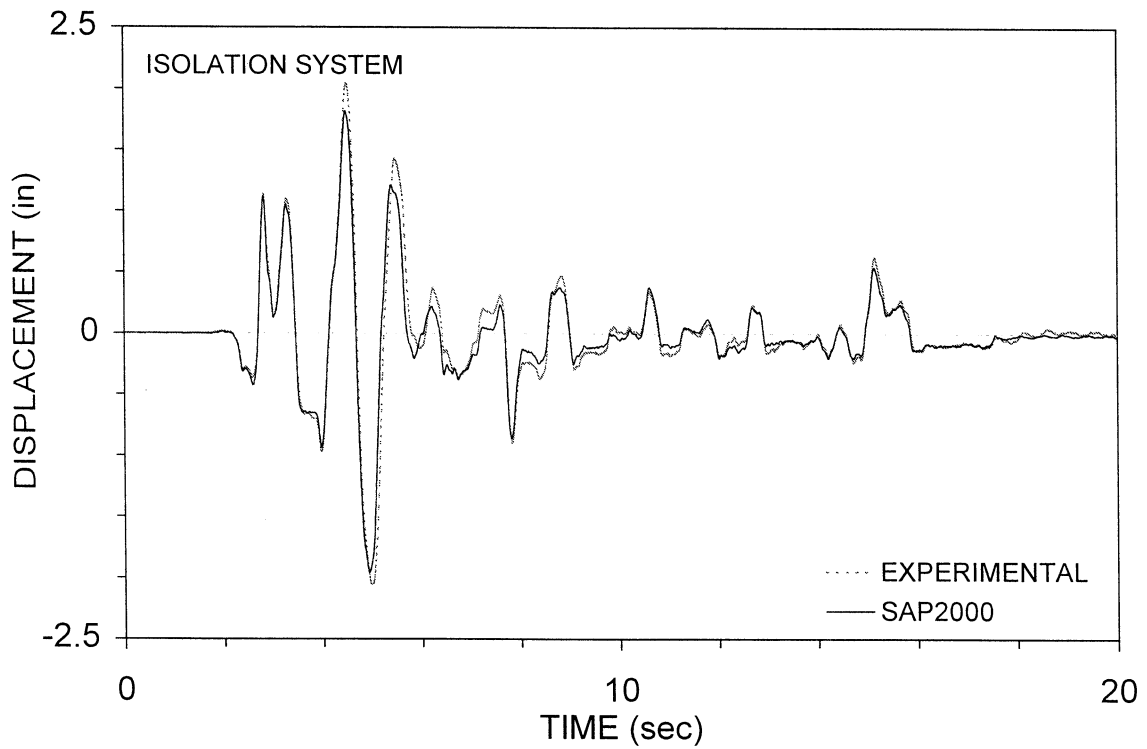
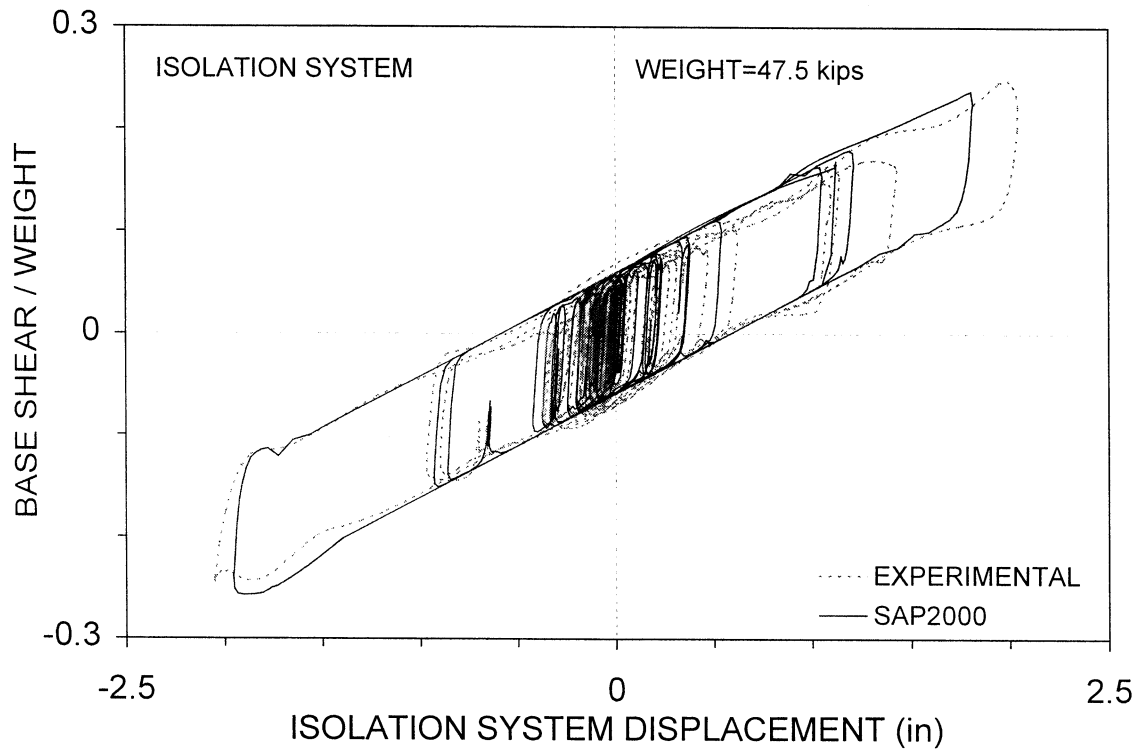
EXPERIMENTAL MODE SHAPES (associated with horizontal displacements)

FLOOR	MODE 1	MODE 2	MODE 3	MODE 4	MODE 5	MODE 7
7	1	0.918	0.812	0.704	0.471	0.363
6	0.914	0.467	-0.197	-0.967	-0.896	-0.700
5	0.822	-0.193	-1	-0.742	0.346	1
4	0.675	-0.798	-0.513	1	0.493	-0.755
3	0.479	-1	0.708	0.653	-0.948	0.033
2	0.289	-0.755	0.844	-0.932	0.542	0.538
1	0.138	-0.373	0.473	-0.837	1	-0.868

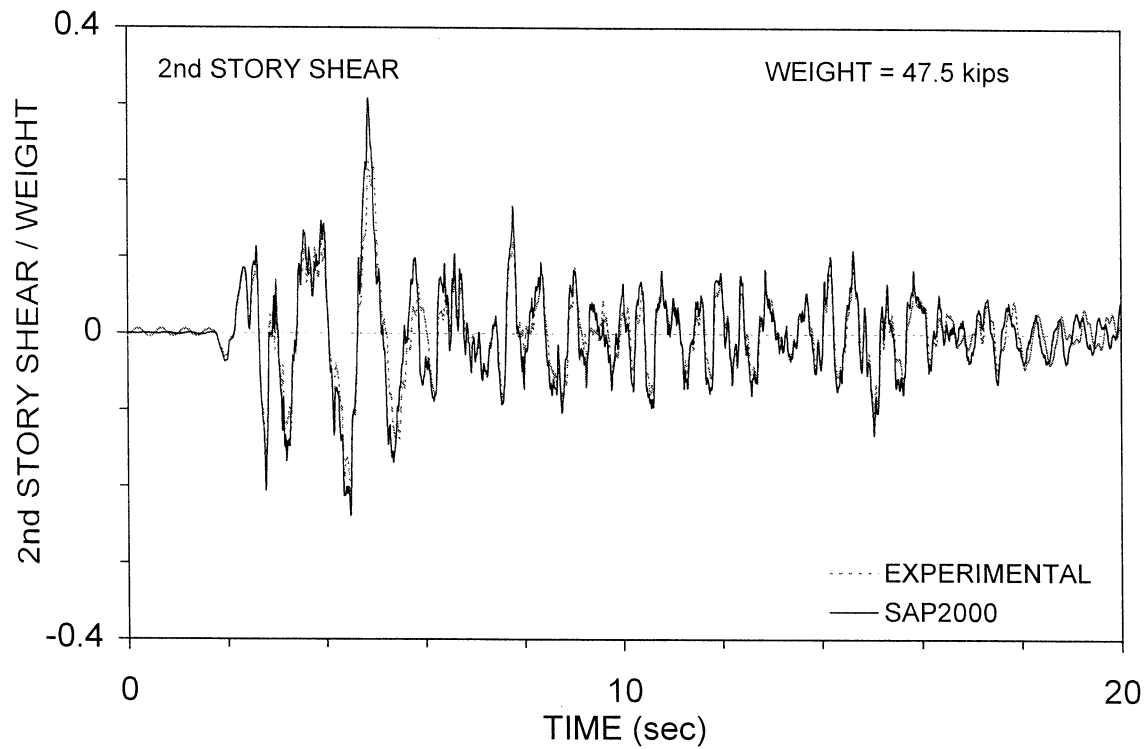
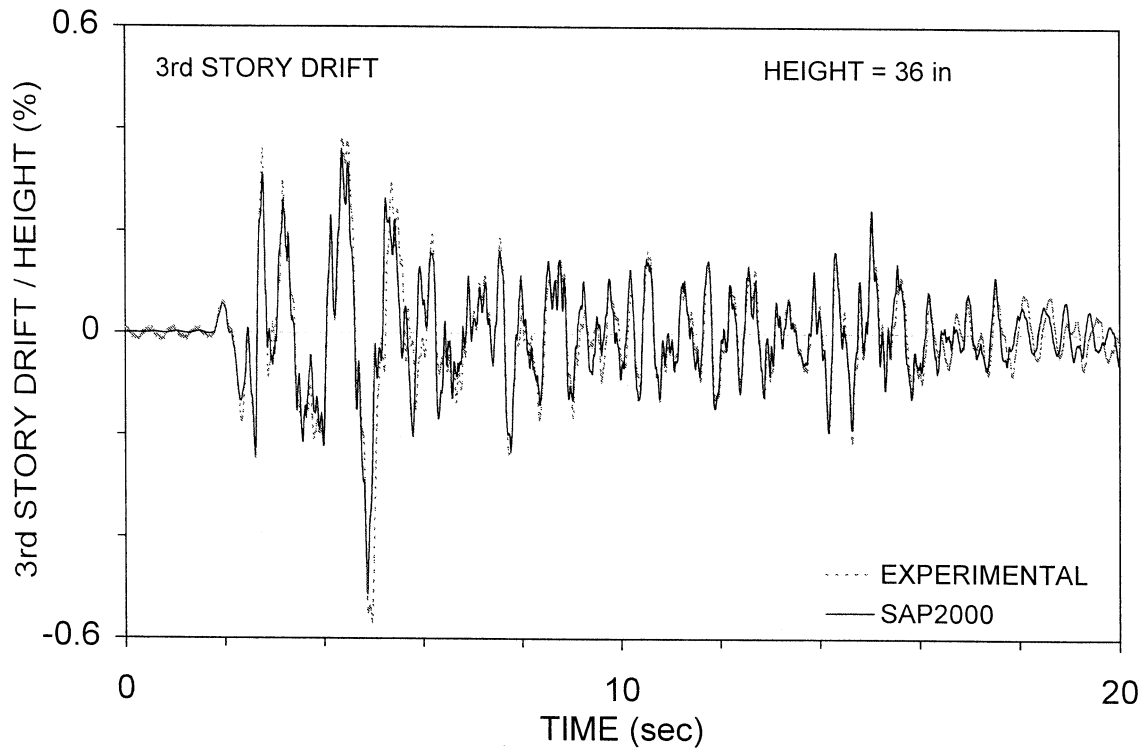
SAP2000 MODE SHAPES

FLOOR	MODE 1	MODE 2	MODE 3	MODE 4	MODE 5	MODE 7
7	1	0.982	0.978	1.506	0.655	0.410
6	0.941	0.538	-0.081	-1.280	-1.094	-0.986
5	0.837	-0.110	-1	-1.605	0.123	1
4	0.692	-0.707	-0.857	1	1.022	-0.376
3	0.514	-1	0.196	1.793	-0.771	-0.484
2	0.315	-0.875	1.053	-0.668	-0.535	1.046
1	0.138	-0.470	0.890	-1.893	1	-0.786

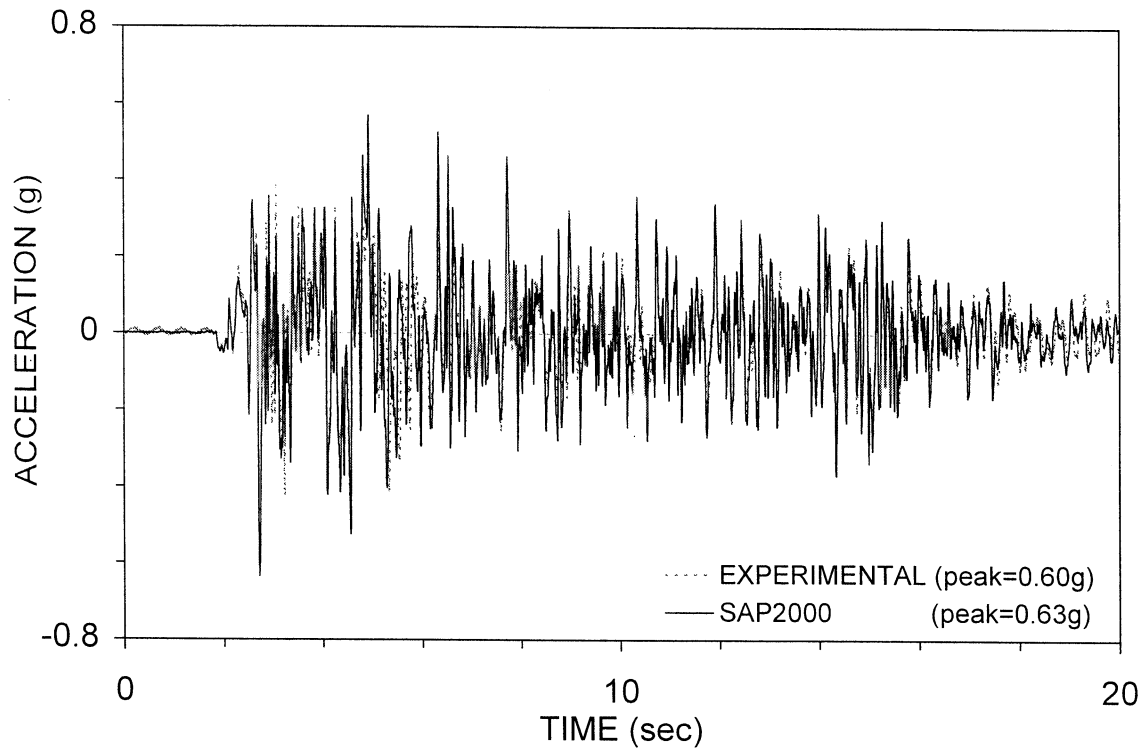
error since it was not directly measured but rather obtained by computation on the basis of the experimental accelerations and the imprecisely known distribution of mass.



**Figure 4-3 Comparison of Analytical and Experimental Results on the Base Shear-Displacement Loop and Isolation System Displacement History**



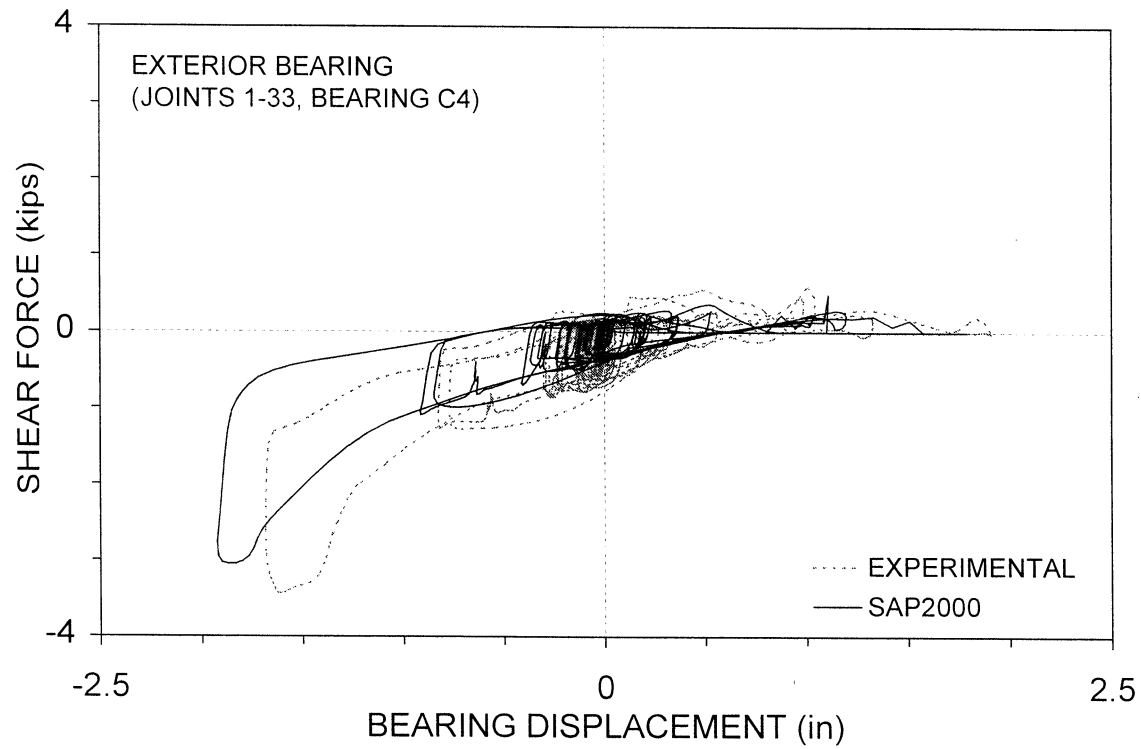
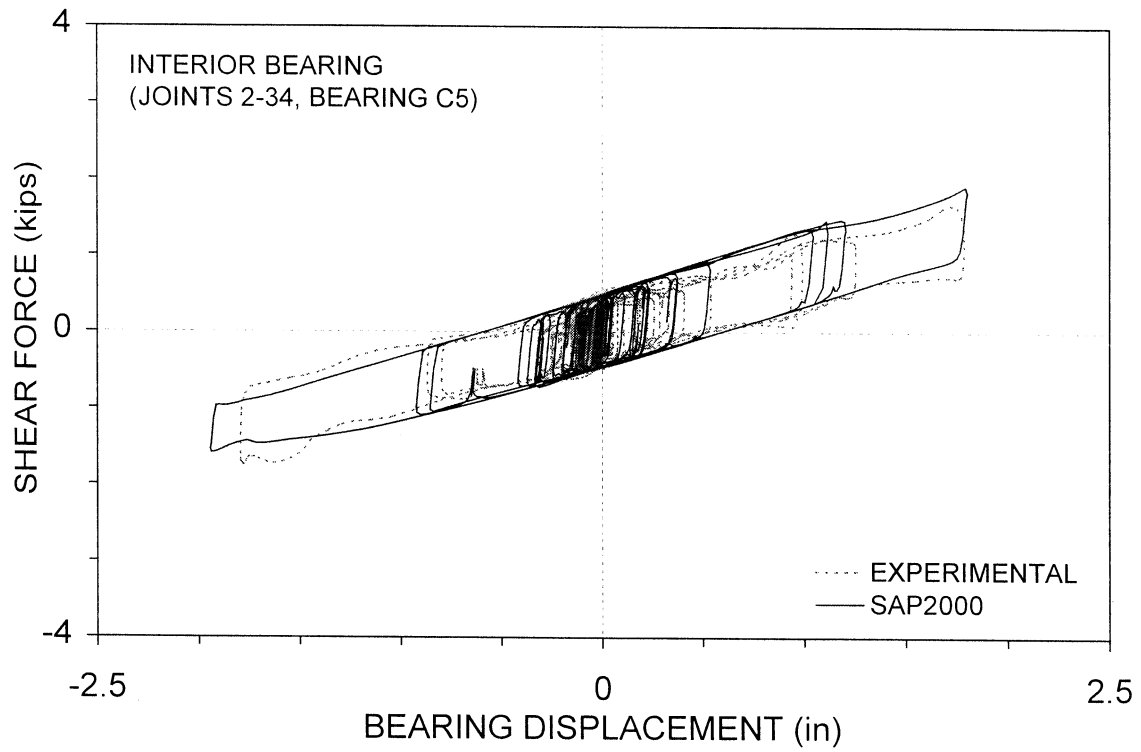
**Figure 4-4 Comparison of Analytical and Experimental Results on Selected Histories of Story Drift and Story Shear Force**



**Figure 4-5 Comparison of Analytical and Experimental Results on the 7th Floor Acceleration**

Figure 4-6 presents experimental and analytical force-displacements for one exterior (C4) and one interior bearing (C5). These two bearings (see Figure 4-1) were instrumented to measure the bearing displacements. Since the analysis was performed with a planar representation of the structure, the calculated bearing shear forces were divided by factor of two to obtain the force in a single bearing. The exterior bearing underwent significant variation in the axial load and experienced uplift. The SAP2000 program does predict this behavior with good accuracy given the uncertainty in the gravity load on the bearing. It should be noted that the gravity loads on the bearings were not exactly known and they could very well have been different than assumed in the analysis.





**Figure 4-6 Comparison of Analytical and Experimental Shear Force-Bearing Displacement Loops**

The analytical results presented in Figures 4-3 to 4-6 were obtained with a SAP2000 model of which the important features are: (a) use of a very low value for the linear effective stiffness **ke** related to the shear degrees of freedom of element **Isolator2**, (b) use of vertical damping elements at the isolator locations, and (c) use of eleven eigenvectors.

Analyses were also performed using other combinations of parameters and different modeling. Specifically, analyses were performed without the vertical damping elements at the isolator locations; the base shear force-displacement loop are presented in Figure 4-7. Analyses were performed with either a) eleven eigenvectors, or b) with 26 Ritz vectors, and with either a) linear effective stiffness in the shear degrees of freedom of the **Isolator2** elements being very low, or b) realistic values (2.1 kip/in for the interior and 1.05 kip/in for the exterior bearings). The results show large fluctuations in the calculated force. The prediction improves with the use of larger number of Ritz vectors (maximum possible was 26 for the model in SAP2000) but the analytical prediction is poor. No improvements were noticed when a larger number of eigenvectors was used. It is likely that with more refined modeling (e.g., without constraints) and a sufficiently large number of properly constructed Ritz vectors, response of acceptable accuracy could be obtained without the use of vertical damping elements.

Figure 4-8 presents the experimental and the calculated loops of base shear-isolation system displacement and of shear force-bearing displacement for the exterior bearing. The analytical response is obtained with a model having vertical damping elements, eleven eigenvectors and realistic values for the linear effective stiffness for the shear degrees of freedom of the **Isolator2** elements. The results of these figures should

be compared to those of Figures 4-3 and 4-6. Such a comparison reveals that for the **Isolator2** element, use of either a realistic value for the linear effective stiffness or a very small value leads to nearly identical results.

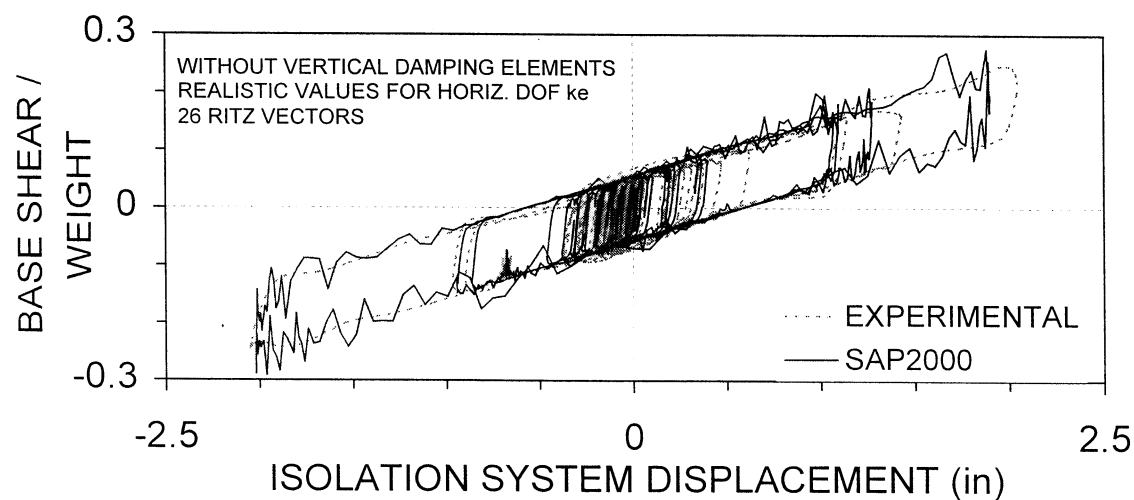
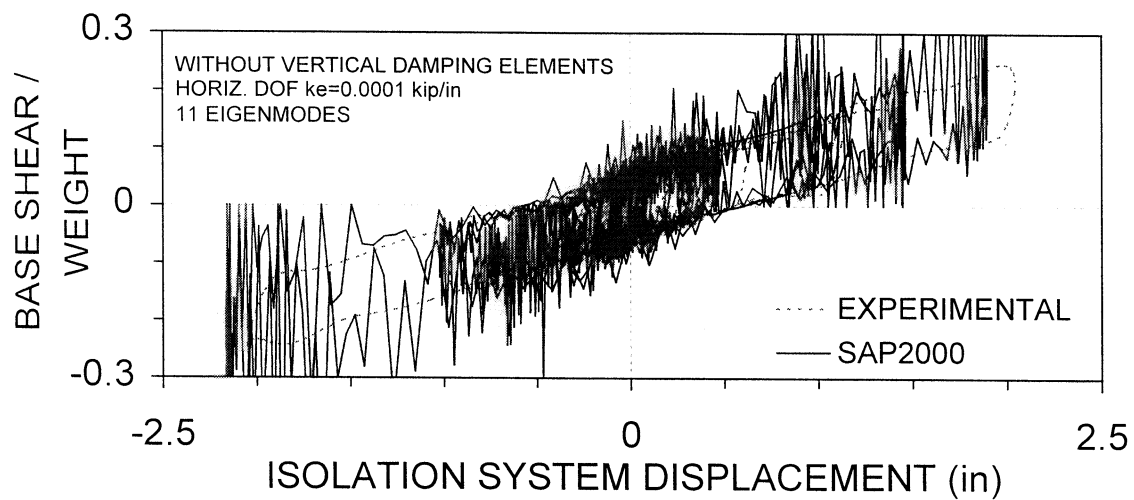
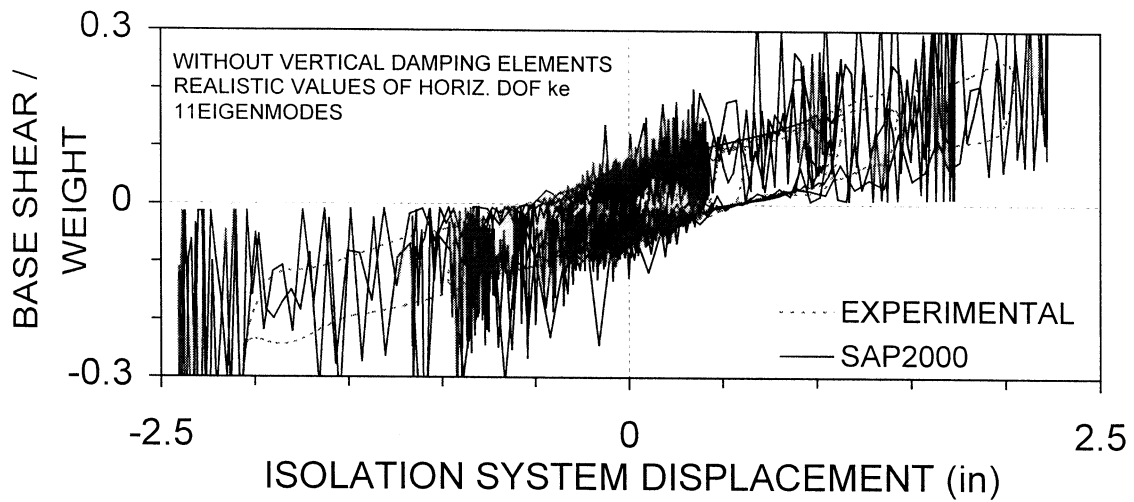
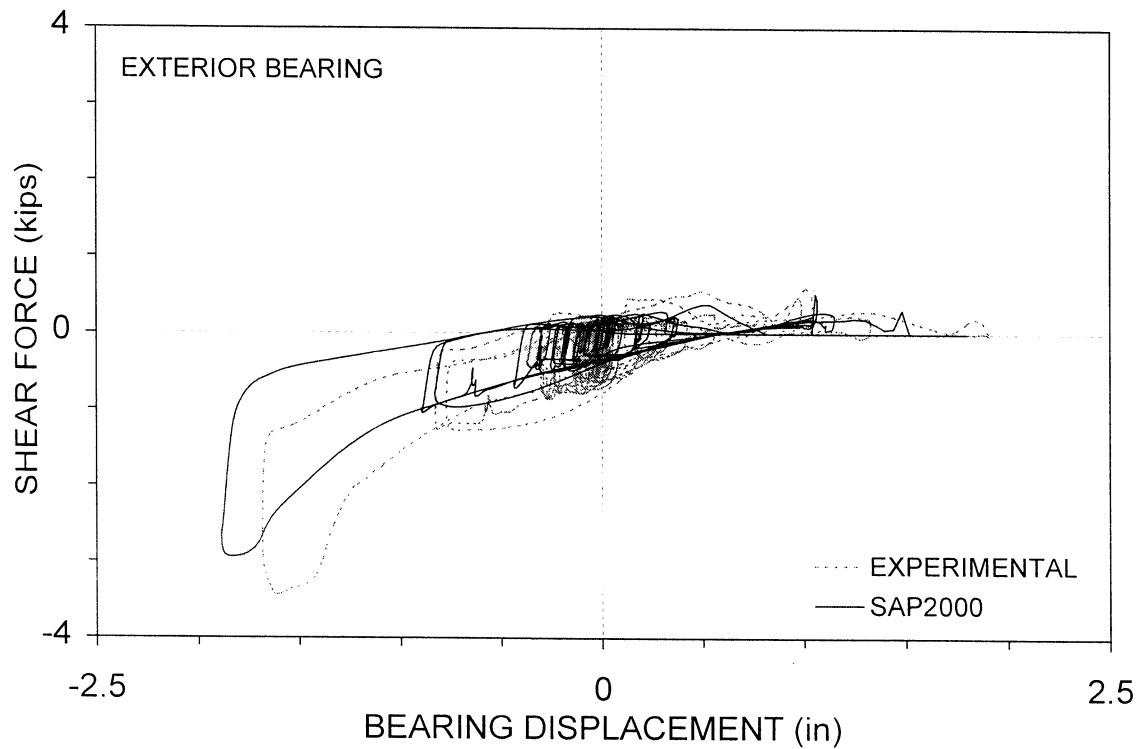
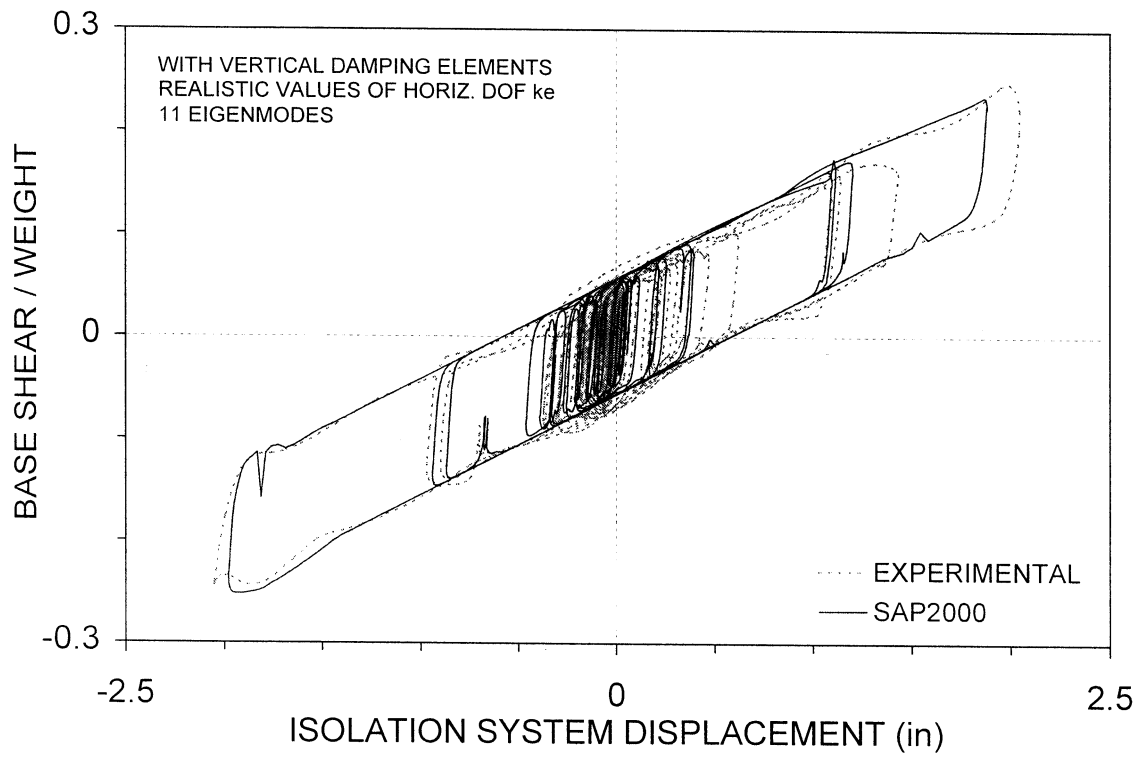


Figure 4-7 Comparison of Analytical and Experimental Results on the Base Shear-Displacement Loop. Analysis without Vertical Damping Elements.



**Figure 4-8 Comparison of Analytical and Experimental Results on Shear Force-Displacement Loops. Analysis with Vertical Damping Elements and Realistic Values of Linear Effective Stiffness.**



## **SECTION 5**

### **ANALYSIS OF EXPERIMENTAL RESPONSE OF A 3-STORY BUILDING MODEL WITH LINEAR AND NONLINEAR VISCOUS FLUID DAMPERS**

#### **5.1 Introduction**

The structure analyzed in this section is a 3-story quarter length scale steel model with a fluid viscous energy dissipation system. This model was used in several shake table studies of active, semi-active and passive motion control systems (Chung et al., 1988; Constantinou and Symans, 1992; Symans and Constantinou, 1995; Seleemah and Constantinou, 1997). Particularly, the study of Seleemah and Constantinou (1997) included the use of linear and nonlinear fluid viscous dampers in a passive energy dissipation system. It is a simple structural system and thus represents an ideal situation for verifying the viscous damper element in SAP2000.

#### **5.2 Description of Tested Structure**

The structure was originally designed as a small structural testing system, and not as a scaled model of an actual building. It underwent extensive testing over a period of ten years and at the time prior to the tests of Seleemah and Constantinou (1997) it was damaged, had several cracks and exhibited brittle behavior. The frame was repaired by enhancing the section of the first story columns, by inhibiting the further propagation of cracks (drilling of holes at crack tips) and by welding several small plates over the cracks in order to provide for proper load paths. Figure 5-1 shows a schematic of the repaired structure, including the added weight.

The model was tested in a variety of configurations, of which the one shown in Figure 5-2 is analyzed herein. This configuration is a 3-story moment frame with complete vertical distribution of diagonally placed fluid viscous dampers. The weight at each floor level (including the tributary weight from beams and columns) was 9.38 kN (mass of 9.56 N-s<sup>2</sup>/cm).

Six linear viscous dampers were used (three on each of the two frames), and then in another series of tests six nonlinear dampers were used. Three of the linear dampers were tested to velocities of up to 420 mm/sec and found to exhibit nearly linear behavior, which could be represented as

$$F = C_o \dot{u} \quad (5-1)$$

where  $F$  = force,  $\dot{u}$  = velocity,  $C_o$  = damping coefficient equal to 16 N-sec/mm. The three tested dampers did not have identical behavior, with the actual value of  $C_o$  being in the range of 13.5 to 18.5 N-sec/mm.

All six nonlinear dampers were tested and found to exhibit a behavior described by

$$F = C_o |\dot{u}|^\alpha \text{sign}(\dot{u}) \quad (5-2)$$

with  $\alpha = 0.5$  and  $C_o$  in the range of 220 to 300 N-(sec/mm)<sup>1/2</sup>. Specifically, two dampers had  $C_o = 220$  N-(sec/mm)<sup>1/2</sup> and were placed at the third story, two had  $C_o = 235$  N-(sec/mm)<sup>1/2</sup> and were placed at the second story, and the two had  $C_o = 300$  N-(sec/mm)<sup>1/2</sup> and were placed at the first story.



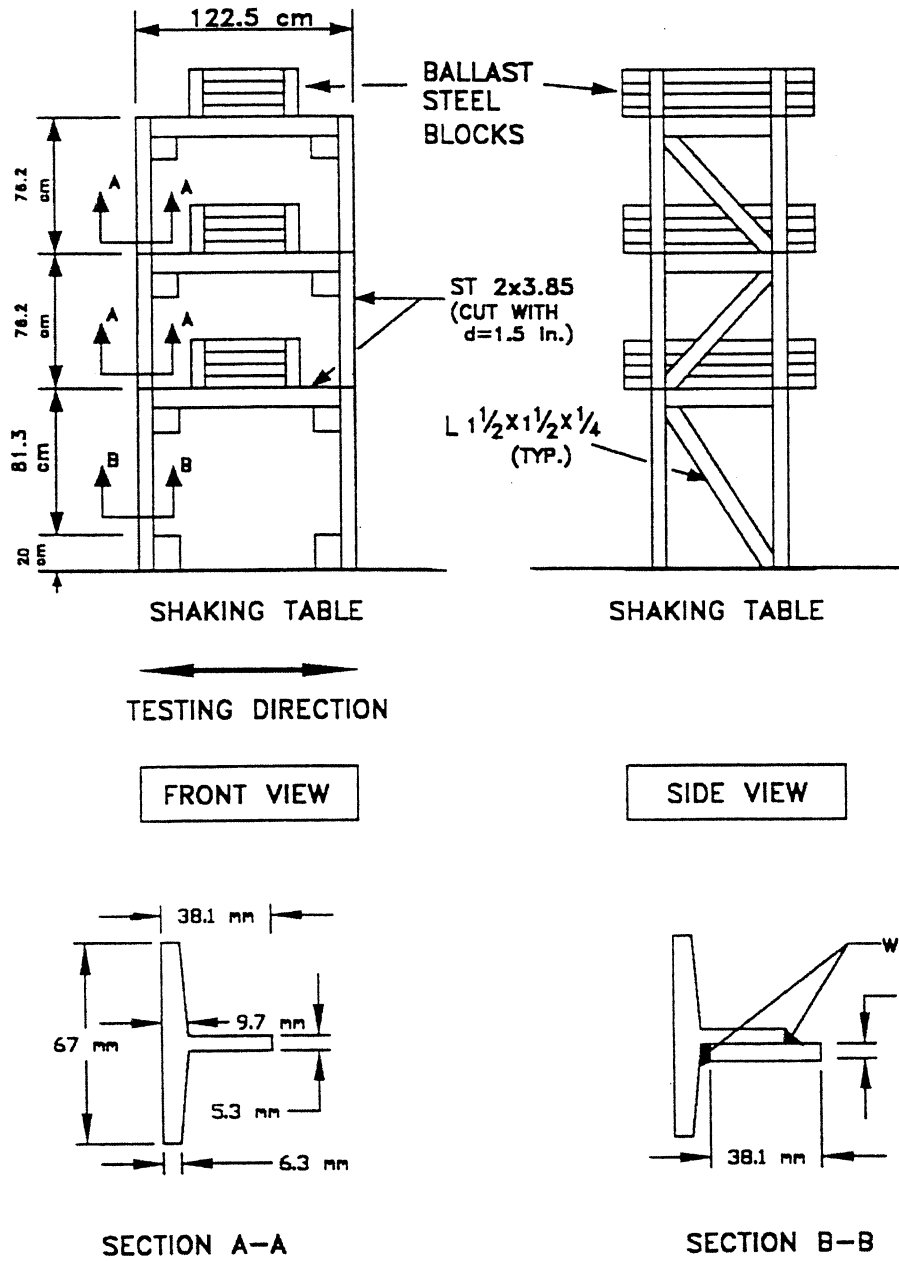
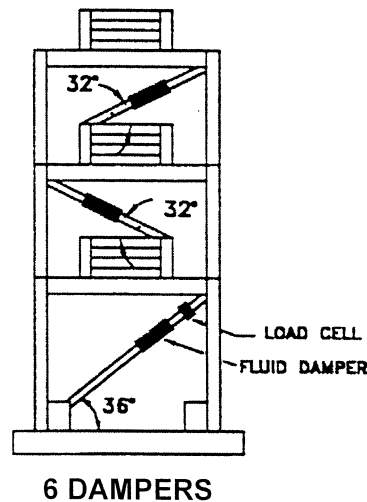


Figure 5-1 Schematic of Tested Model



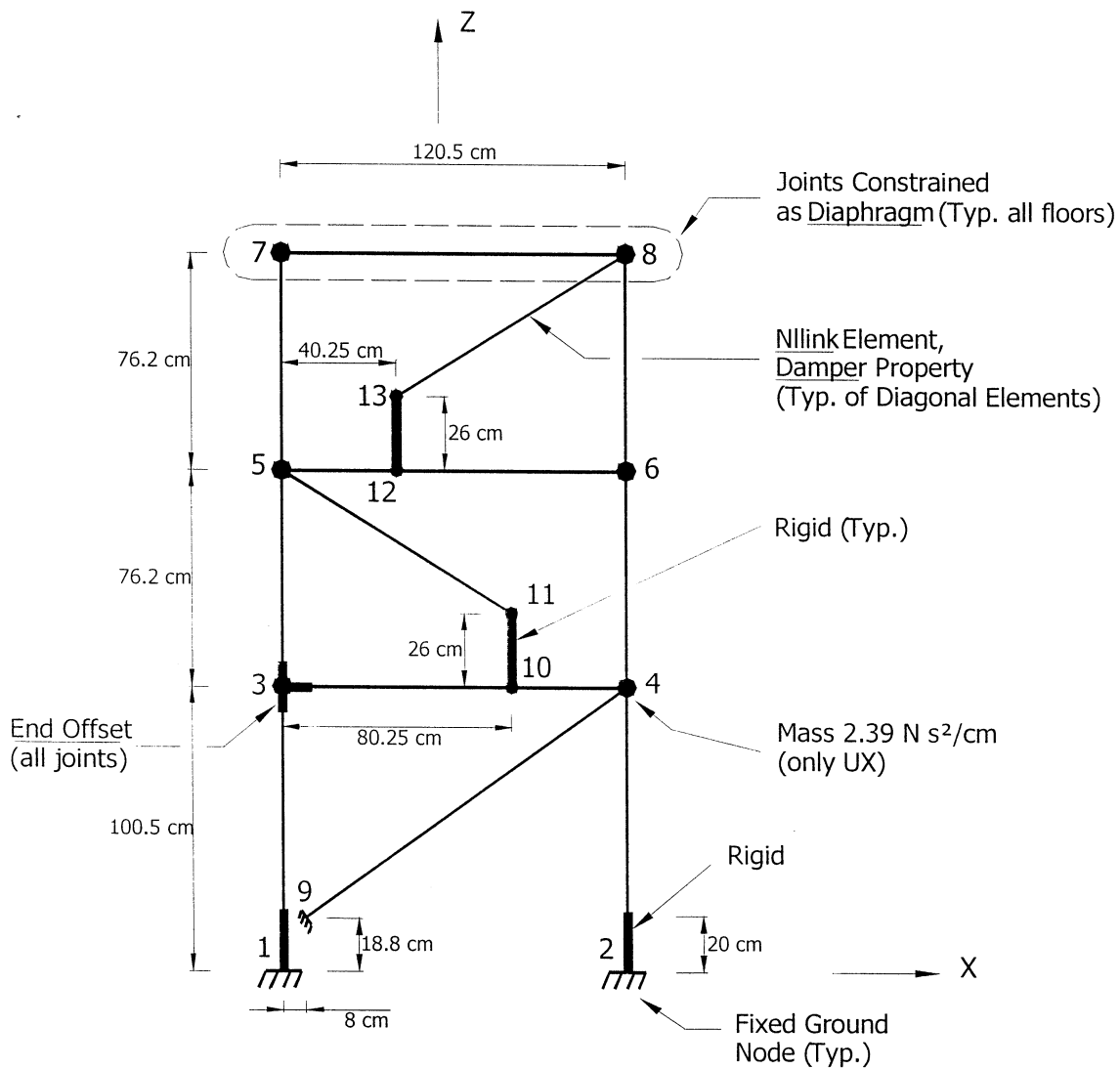
**Figure 5-2 Schematic of One of the Tested Configurations**

Interestingly, (5-2) described well the behavior of the nonlinear dampers for velocities exceeding about 15 mm/s. For velocities below this limit the behavior was essentially linear.

The model was tested with only horizontal seismic excitation using several scaled historic earthquake records. The experimental results obtained for the S00E component of the 1940 El Centro record (tests No. L36E100 and N36E100) are compared herein with the analysis results of SAP2000. This record was compressed in time by factor of two to satisfy the similitude requirements of the quarter length scale model.

### **5.3 Modeling in SAP2000**

Due to symmetry, only one-half of the structure was modeled as a plane frame. Figure 5-3 illustrates the model. Masses were concentrated at the column-to-beam joints, and floor joints were constrained as **diaphragm** for reducing the degrees of freedom and for better representing the behavior of the floors which were stiffened by the added steel



**Figure 5-3 Illustration of SAP2000 Model of 3-story Frame with Viscous Dampers**

weights. **Frame** elements were used together with specified **offset** and **rigid-end-factor** values. The value of the rigid end factor was specified to be 0.6 on the basis of eigenvalue analysis of the frame without dampers and comparison of experimental and analytical periods and mode shapes. Table 5-1 presents a comparison of these modal properties, where it may be seen that there is an excellent agreement between the experimental and analytical results.

There are two options in SAP2000 for modeling linear dampers:

- (a) Element, **Nlink, damper** property, linear analysis type with **ke** = 0 and **ce** = 16 N-sec/mm.
- (b) Element **Nlink, damper** property, nonlinear analysis type with **ke** = 0, **k** = 1,000,000 N/cm, **c** = 16 N-sec/mm and **cexp** = 1.0.

The value of stiffness **k** is large enough to ensure that the element behaves as a pure damper. The value is also consistent with the actual stiffness of the braces used to connect the dampers to the frame. These braces were 1½ x 1½ x ¼ equal leg angles with length of about either 35 or 70 cm. Their actual stiffness was larger than 1,000,000 N/cm. Both options were used and the calculated response was not exactly the same.

The input files in the supplied diskette contain further information on the specified damping ratios for each of the three modes of vibration. The specified damping ratios are those identified in the experiments for the frame without dampers. It should be noted that due to the modeling with constrained floor nodes, rigid elements and horizontal only masses, the model has effectively three degrees of freedom. Accordingly, it is essentially the same as that used by Seleemah and Constantinou (1997) for the analysis of the tested frame.

**Table 5-1 Experimental and Analytical Modal Properties of 3-story Model without Dampers**

PERIOD (sec)

MODE	EXPERIMENTAL	SAP2000
1	0.439	0.437
2	0.133	0.135
3	0.070	0.074

EXPERIMENTAL MODE SHAPES  
(associated with horizontal displacements)

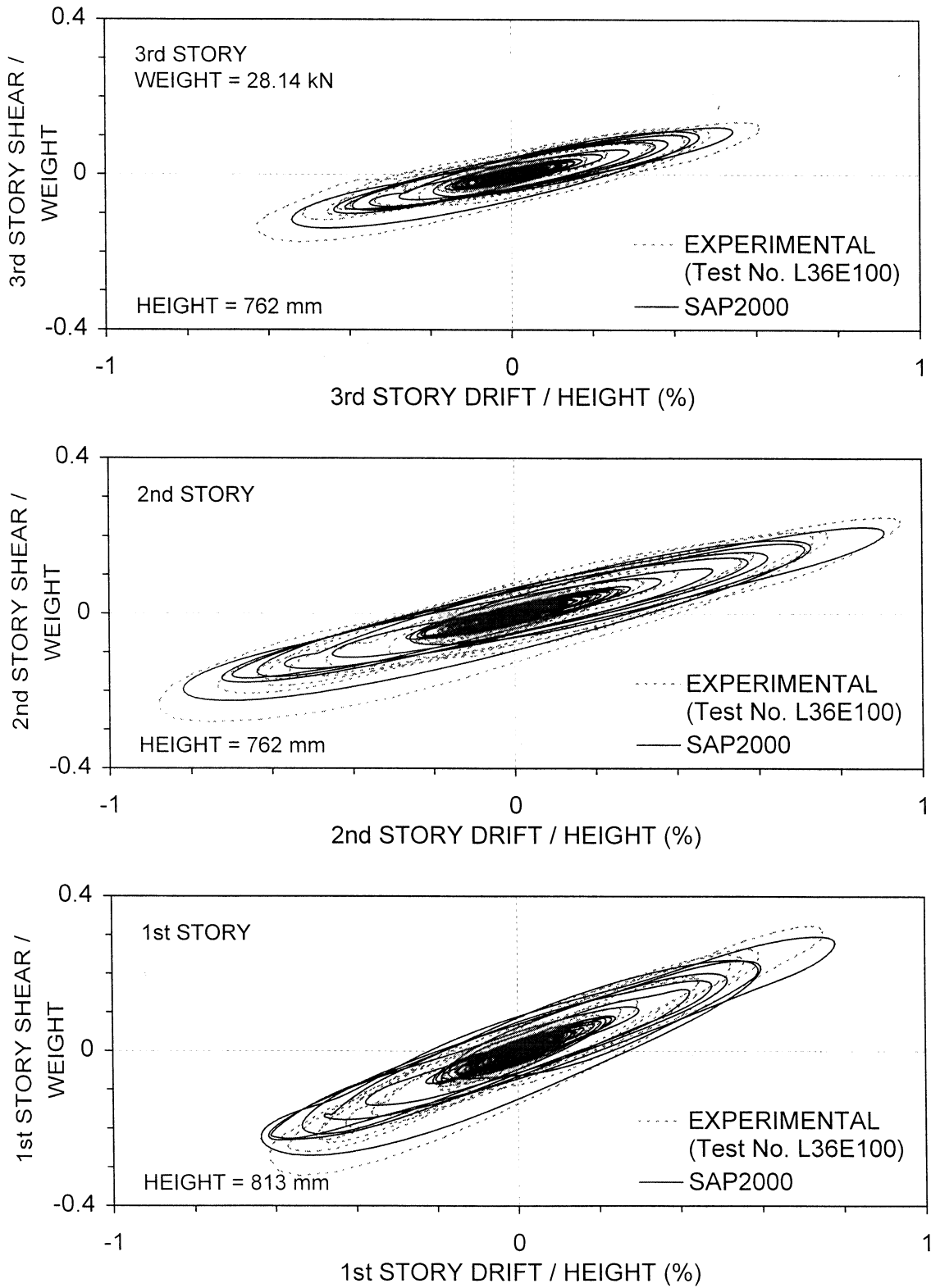
FLOOR	MODE 1	MODE 2	MODE 3
3	1	1	1
2	0.7360	-0.8430	-2.7270
1	0.3600	-1.0160	3.1740

SAP2000 MODE SHAPES

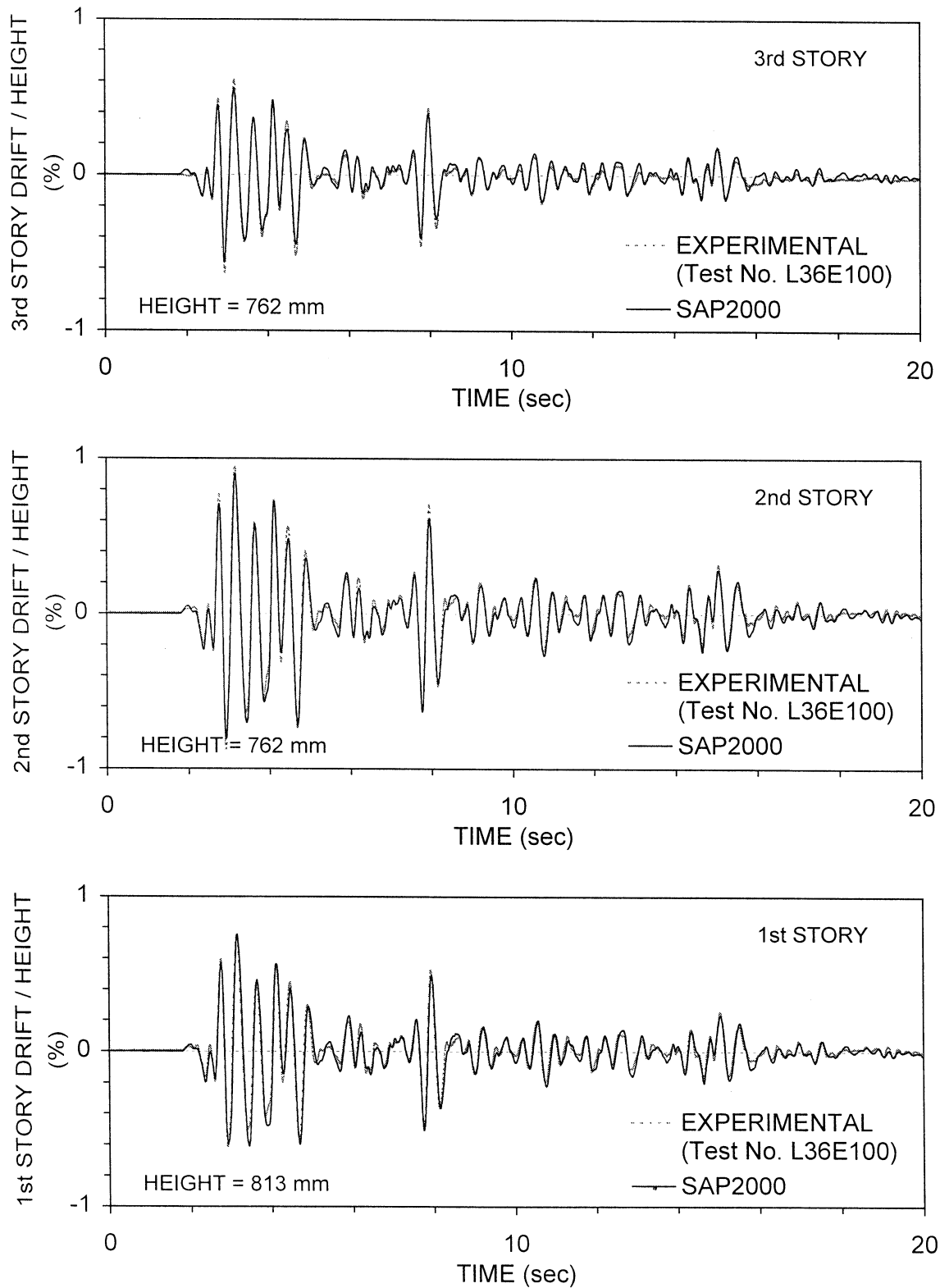
FLOOR	MODE 1	MODE 2	MODE 3
3	1	1	1
2	0.7471	-0.8246	-2.7175
1	0.3469	-1.0960	2.9696

#### 5. 4 Analysis Results and Comparison to Experiment

Figures 5-4 and 5-5 present calculated and experimental story shear force-drift loops and histories of story drift for the structure with linear dampers. The analysis was conducted for the linear model of dampers and using the linear analysis option. The experimental drifts were directly measured with displacement transducers, whereas the experimental shear forces were obtained by calculation from the floor acceleration records and the estimated distribution of mass. The two sets of results are in good agreement. In general, the results of SAP2000 are essentially the same as those obtained in the analyses of Seleemah and Constantinou (1997).



**Figure 5-4 Comparison of Analytical and Experimental Normalized Story Shear Force-Drift Loops of Structure with Linear Dampers (linear analysis type, linear damper model)**



**Figure 5-5 Comparison of Analytical and Experimental Histories of Drift of Structure with Linear Dampers (linear analysis type, linear damper model)**

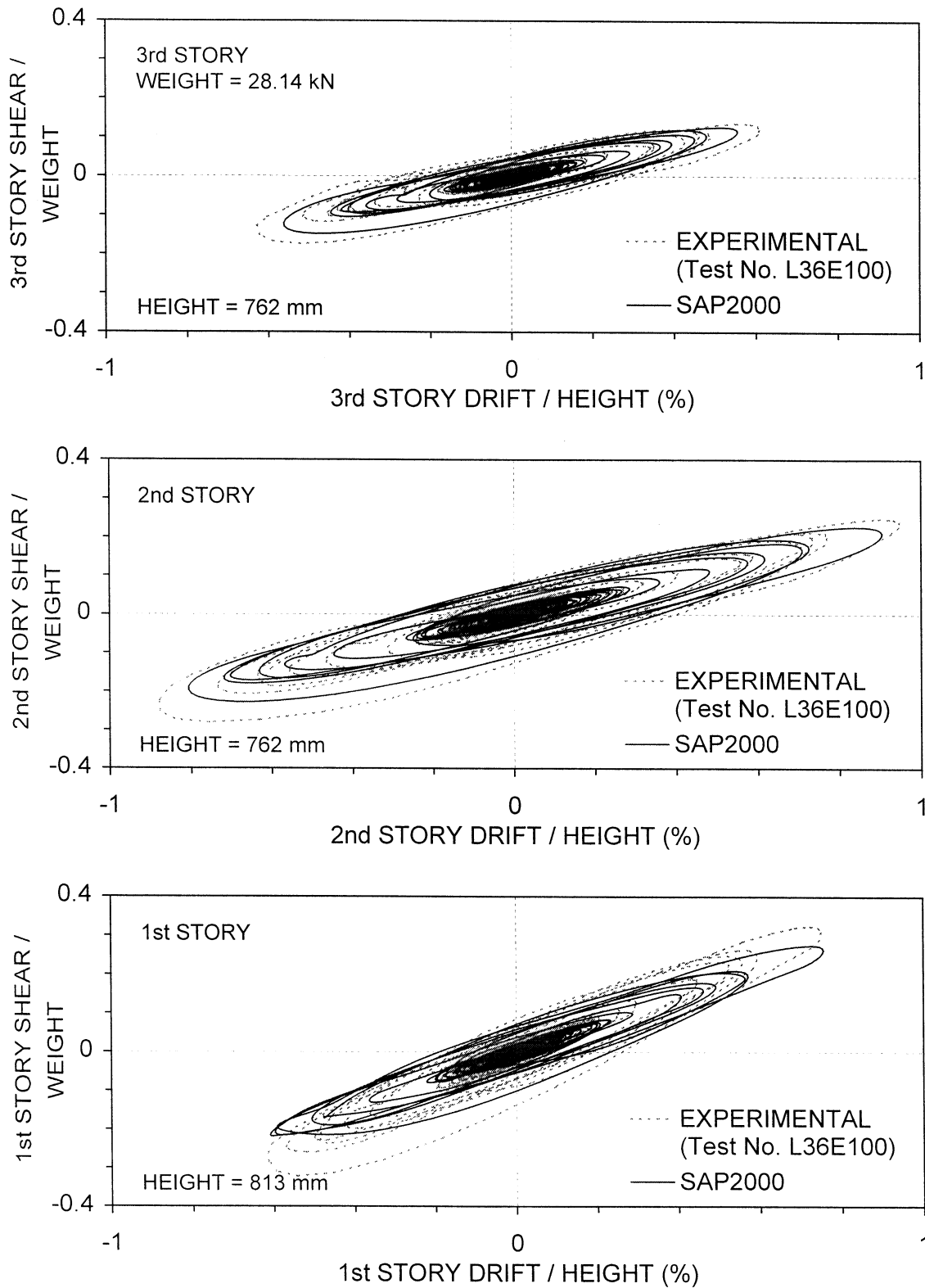
Figure 5-6 is the same as Figure 5-4 but with the analytical results produced with the nonlinear damper model with  $\mathbf{cexp} = 1.0$ . While insignificant for practical purposes, there is a small difference between the calculated responses using the linear and nonlinear damper options.

Finally, Figures 5-7 and 5-8 compare the experimental and calculated response of the structure with nonlinear dampers. Program SAP2000 underestimates the displacement response by a significant amount. The calculated response did not improve when adjustments were made to the stiffness  $\mathbf{k}$  from the realistic value of 1,000,000 N/cm to lower values (250,000 N/cm) or when Ritz rather than eigenvectors were used, or when masses for the vertical degrees of freedom were introduced.

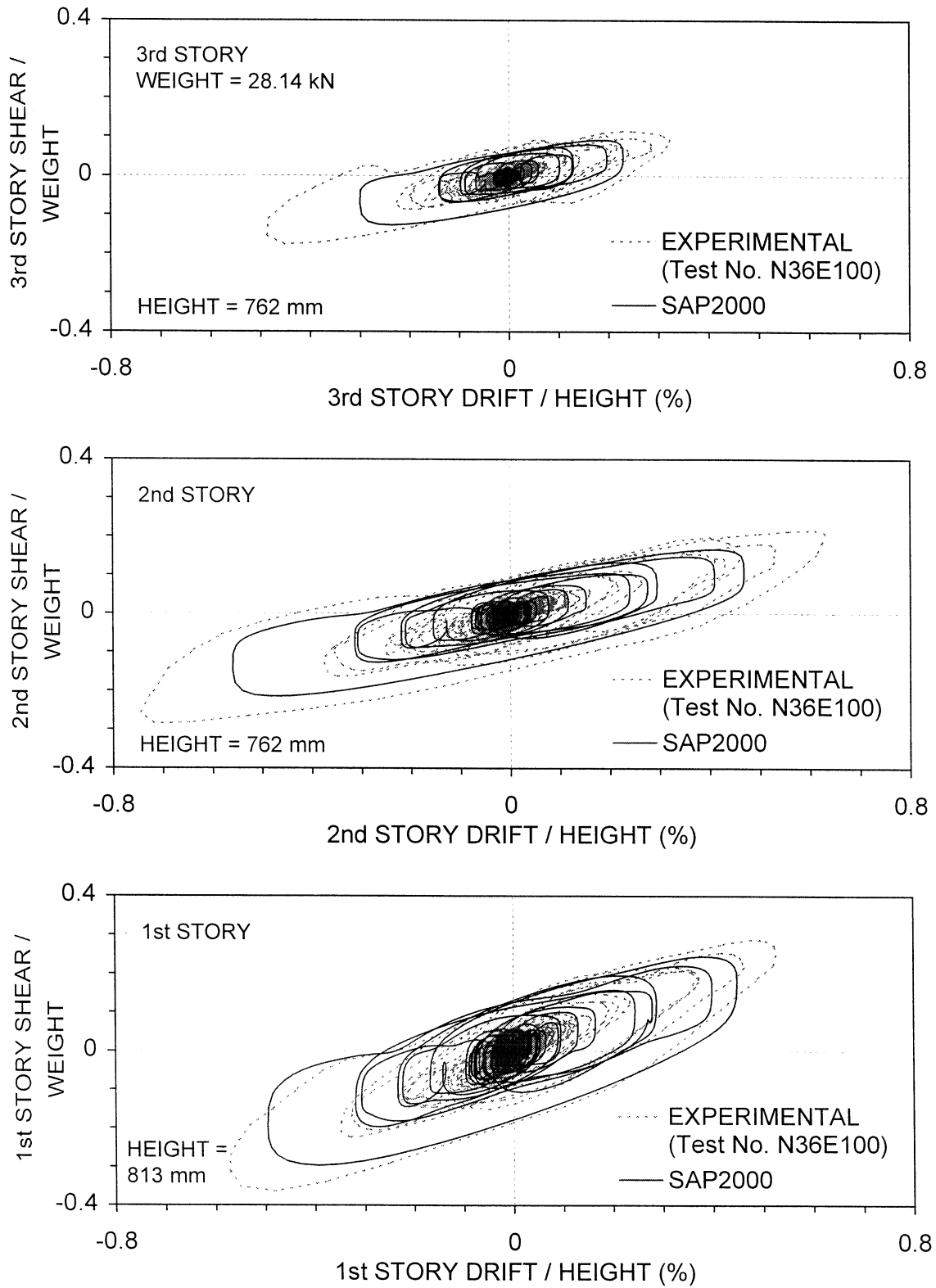
To provide further insight into this discrepancy, a simple one degree of freedom system was analyzed: an example in Chapter X of Soong and Constantinou (1994) of a linear elastic system with a lumped weight of 7000 kN and period of 2 sec, and with a nonlinear viscous element described by (5-2) with  $C_o = 25.13 \text{ kN (sec/mm)}^{1/2}$  and  $\alpha = 0.5$ . The SAP2000 results were nearly identical to those reported in Soong and Constantinou (1994), which were produced with a rigorous integration scheme using a predictor-corrector method.

The interested reader is referred to Seleemah and Constantinou (1997) for a good comparison of experimental and analytical results, the latter produced with essentially the same model. On the basis of this study, it is likely that a contributor to the discrepancy is the inadequacy of the model of the dampers in SAP2000 to represent the low velocity behavior of the nonlinear dampers.

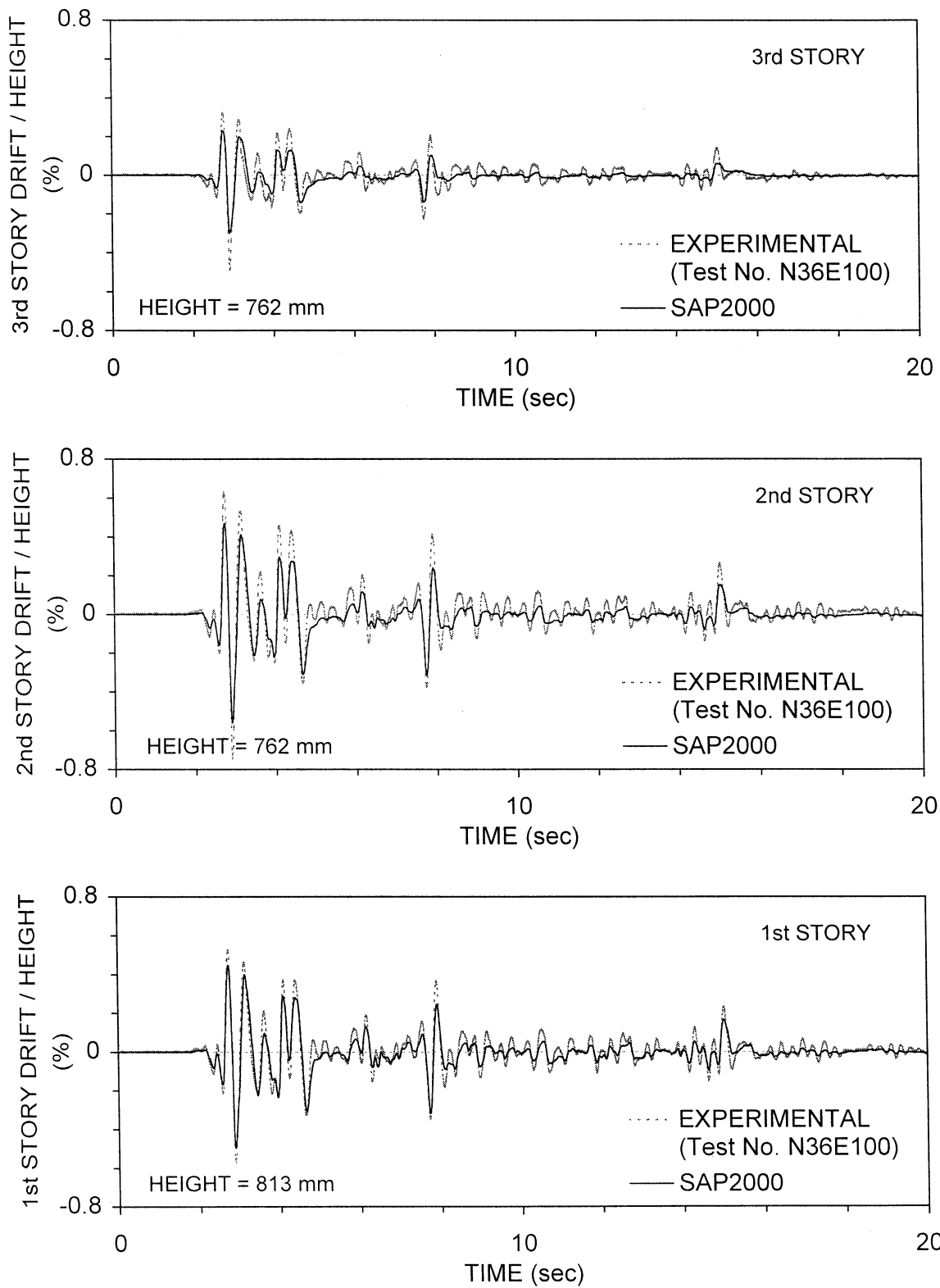




**Figure 5-6 Comparison of Analytical and Experimental Normalized Story Shear Force-Drift Loops of Structure with Linear Dampers (nonlinear analysis type, nonlinear damper model with  $c_{exp} = 1.0$ )**



**Figure 5-7 Comparison of Analytical and Experimental Normalized Story Shear Force-Drift Loops of Structure with Nonlinear Dampers**



**Figure 5-8 Comparison of Analytical and Experimental Histories of Drift of Structure with Nonlinear Dampers**



## SECTION 6

### ANALYSIS OF EXPERIMENTAL RESPONSE OF A MODEL WITH A TOGGLE BRACE-DAMPER ENERGY DISSIPATION SYSTEM

#### 6.1 Introduction

The analyzed structure is a half length scale steel model used to test a novel energy dissipation system configuration termed the **toggle brace-damper**. The concept, theoretical development, and experimental and analytical results are presented in Constantinou et al., (1997) and in the M.S. thesis of Hammel (1997). Moreover, a brief description may be found in Constantinou (1998a).

#### 6.2 Description of Tested Structure

Figure 6-1 illustrates the tested frame. Two such frames were used to support a 143 kN concrete block. The frame is equipped with a toggle brace (part DAC) which effectively acts as a shallow truss. Viscous fluid dampers are installed either in the lower damper configuration (between A and B as shown in Figure 6-1) or in the upper damper configuration (which is more effective) as shown in the photograph of Figure 6-2, which was taken during the shake table testing.

The operation of the toggle brace-damper system is as follows. On lateral displacement of the frame (drift  $u$  as shown in Figure 6-1), joint A moves upwards resulting in extension of the lower damper or compression of the upper damper. The

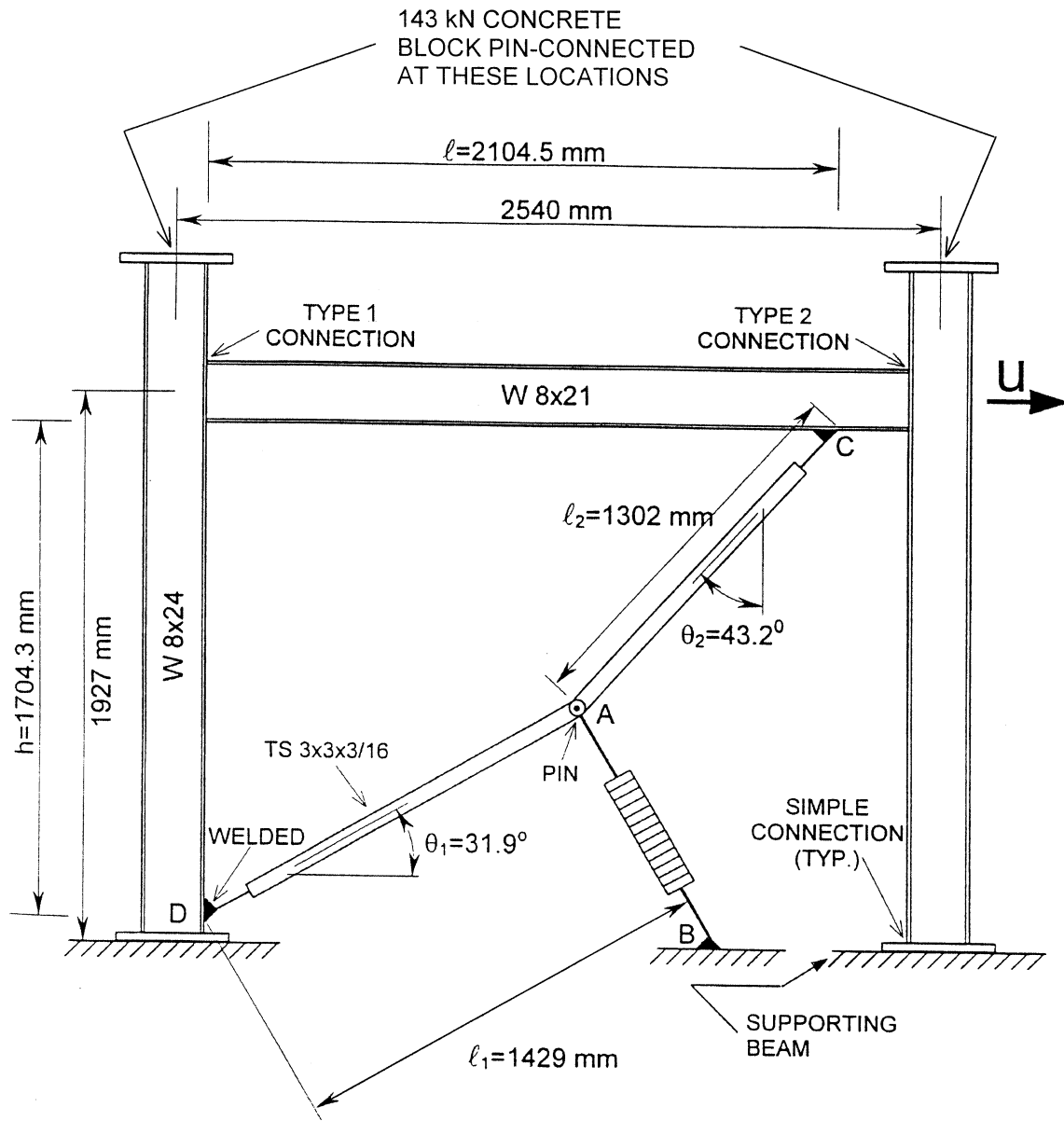
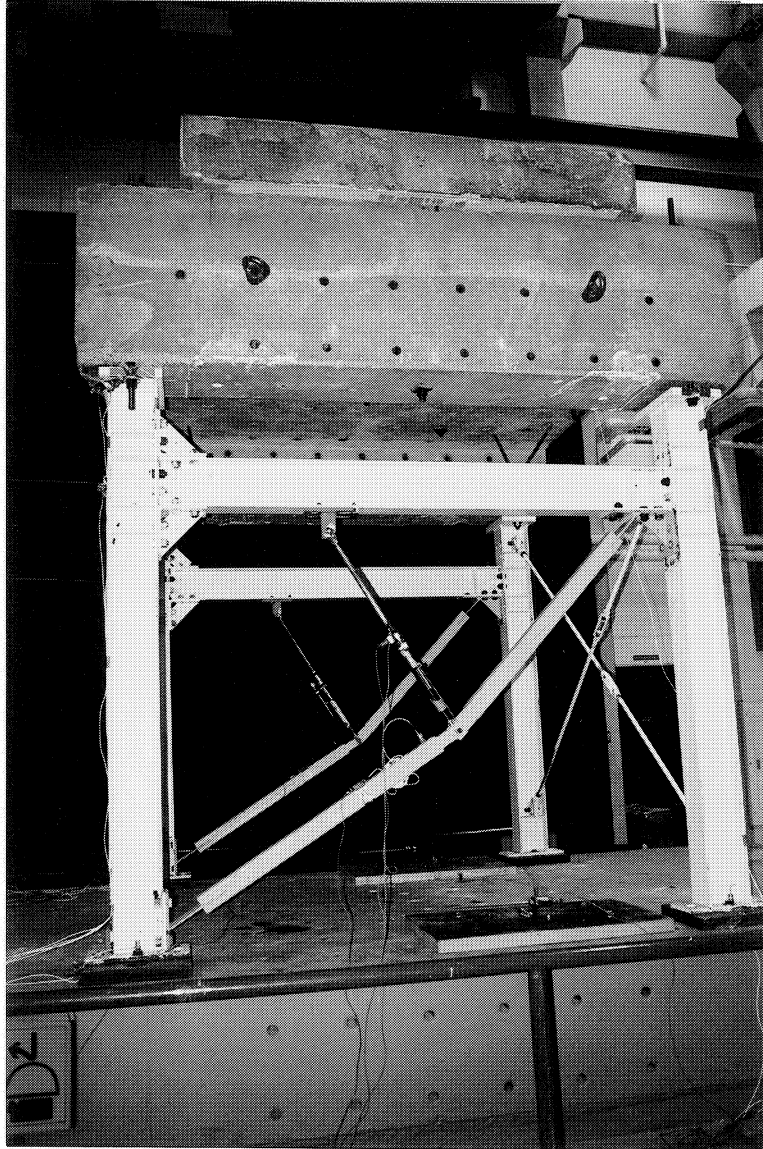


Figure 6-1 Tested Frame with Toggle Brace-Damper System



**Figure 6-2 View of Tested Structure with Upper Damper Configuration on the Shaking Table**

change of length of the damper is the damper displacement  $u_D$ , which is related to the drift  $u$ :

$$u_D = f u \quad (6-1)$$

The magnification factor  $f$  depends on the geometry (specifically angles  $\theta_1$  and  $\theta_2$ ) and the intent is to achieve large values. In the tested configurations,  $f$  assumed values of about 2.5 and 3.0 in the lower and upper damper configurations, respectively. By comparison, a horizontally placed damper on top of a chevron brace has  $f = 1.0$ , and a diagonally placed damper has  $f$  less than 1.0.

Since the energy dissipated is proportional to the product of the peak damper force and the peak damper displacement, effective energy dissipation is achieved with low peak damper force when the system is configured for a large value of the magnification factor  $f$ . This results in a lower cost for the dampers and extends their applicability to stiff structural systems.

The tested structure, as illustrated in Figures 6-1 and 6-2, had a fundamental period of about 0.3 sec, and a damping ratio of 0.04 without dampers, 0.22 with dampers in the lower configuration (as in Figure 6-1) and 0.26 in the upper configuration (as in Figure 6-2). The dampers were fluid viscous with linear behavior as described by (5-1) with  $C_0 = 15.4 \text{ N} \cdot \text{sec}/\text{mm}$  ( $= 88 \text{ lbs} \cdot \text{sec}/\text{in.}$ ) to velocities of up to 500 mm/sec. Two such dampers were used.

The frame was tested on a shake table in a variety of configurations. Herein results are presented for the configuration shown in Figure 6-1 (lower damper) and using the S00E component of the 1940 El Centro earthquake. This record was compressed in time by  $\sqrt{2}$  to satisfy similitude requirements.



### 6.3 Modeling in SAP2000

The modeling was essentially identical to the one developed in the ANSYS program (Swanson Analysis Systems, 1996) and reported in Constantinou et al. (1997). Figures 6-3 and 6-4 illustrate the ANSYS model. The supplied diskette contains the input files, where the coordinates and section properties may be found. It should be noted that the model is that of one frame of the tested structure. Accordingly, half of the total mass of the structure is assigned to it.

Program SAP2000 could model this frame in a more direct way, that is, by using the **offset**, **rigid-end factor** and **constraints** options. However, in the interest of comparing the results of the two programs, the ANSYS model was duplicated in SAP2000.

The linear viscous dampers were modeled in SAP2000 using the **Nlink** element, **damper** property using linear type of analysis while maintaining six eigenvectors with an assigned damping ratio of 0.04.

### 6.4 Analysis Results and Comparison to Experiment

Figures 6-5 to 6-7 present histories of the frame drift (displacement of joint 3 with respect to the ground), histories of the frame acceleration (joint 3), and loops of the damper force vs. damper displacement. The experimental results are the average of the recorded responses at the two frames of the tested structure (east and west sides). The test number is AELRSL02 (see Constantinou et al., 1997).

The figures compare the experimental results to the analytical results obtained by SAP2000, and then the results produced by the two programs. The two programs produce

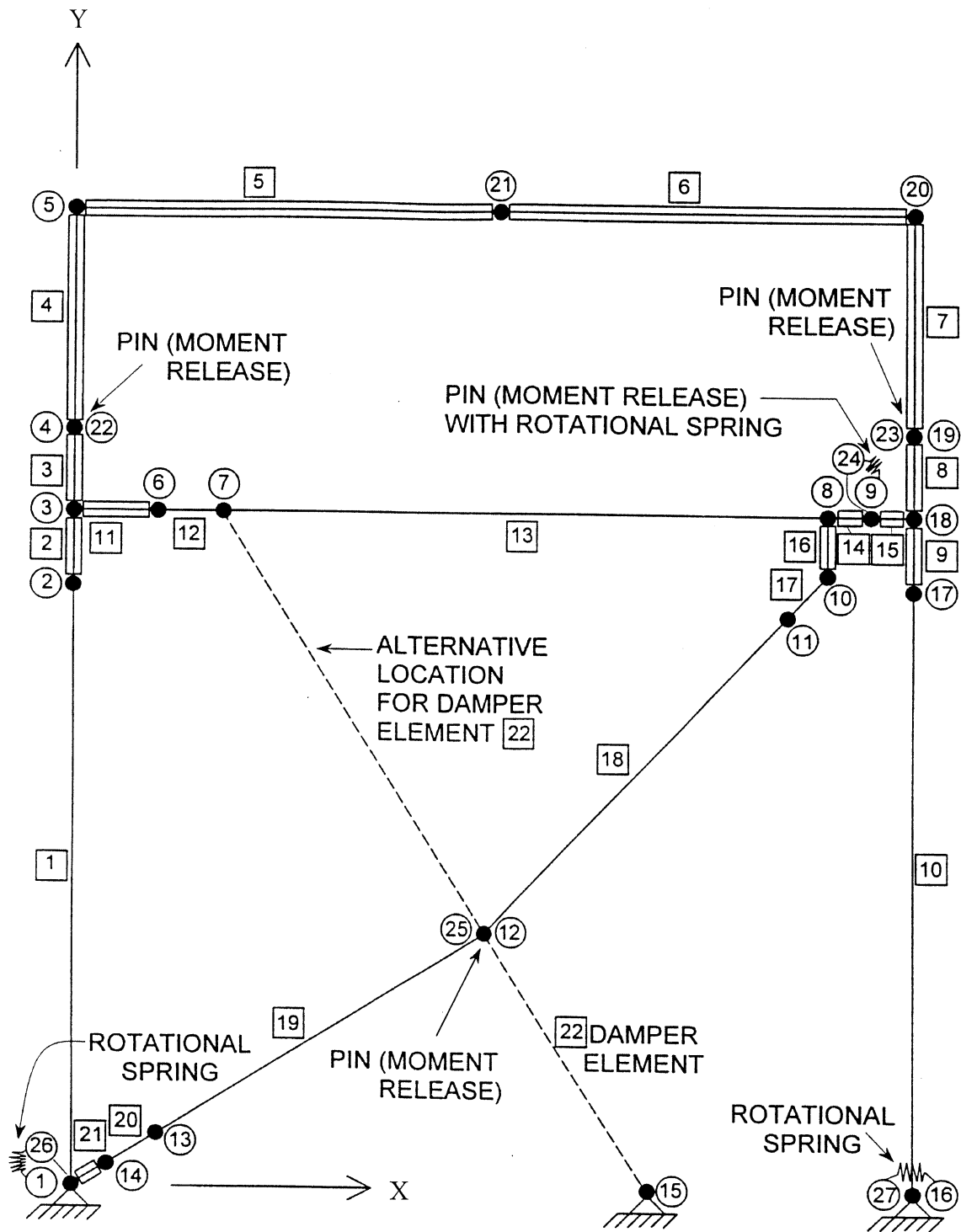
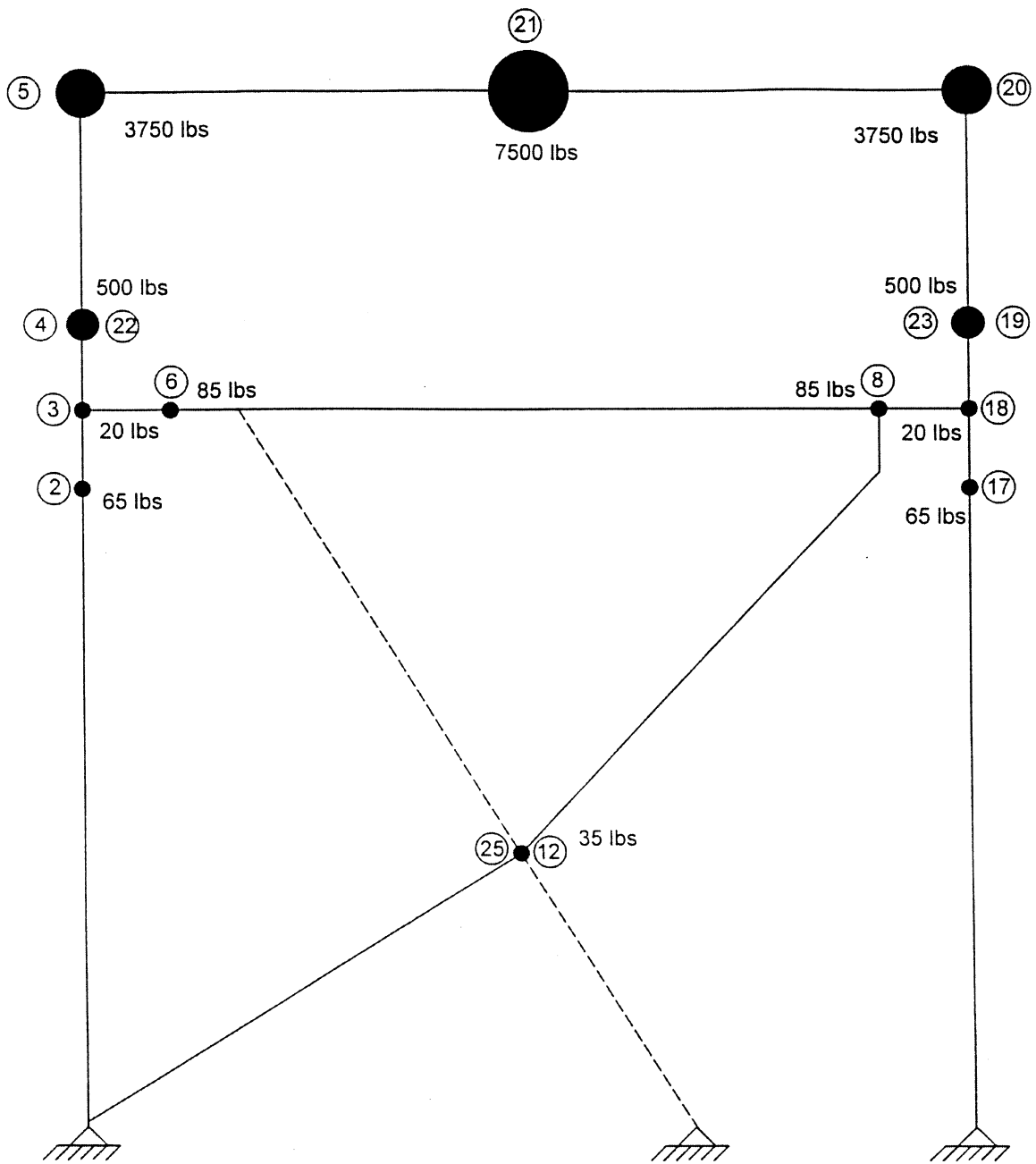
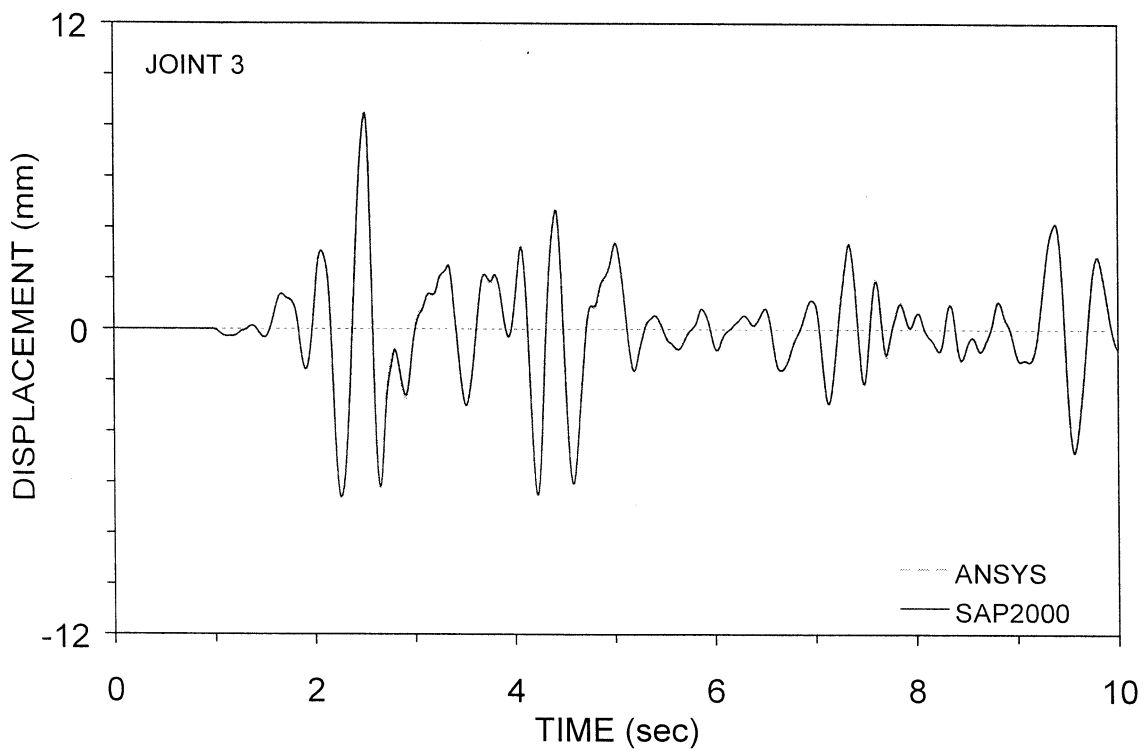
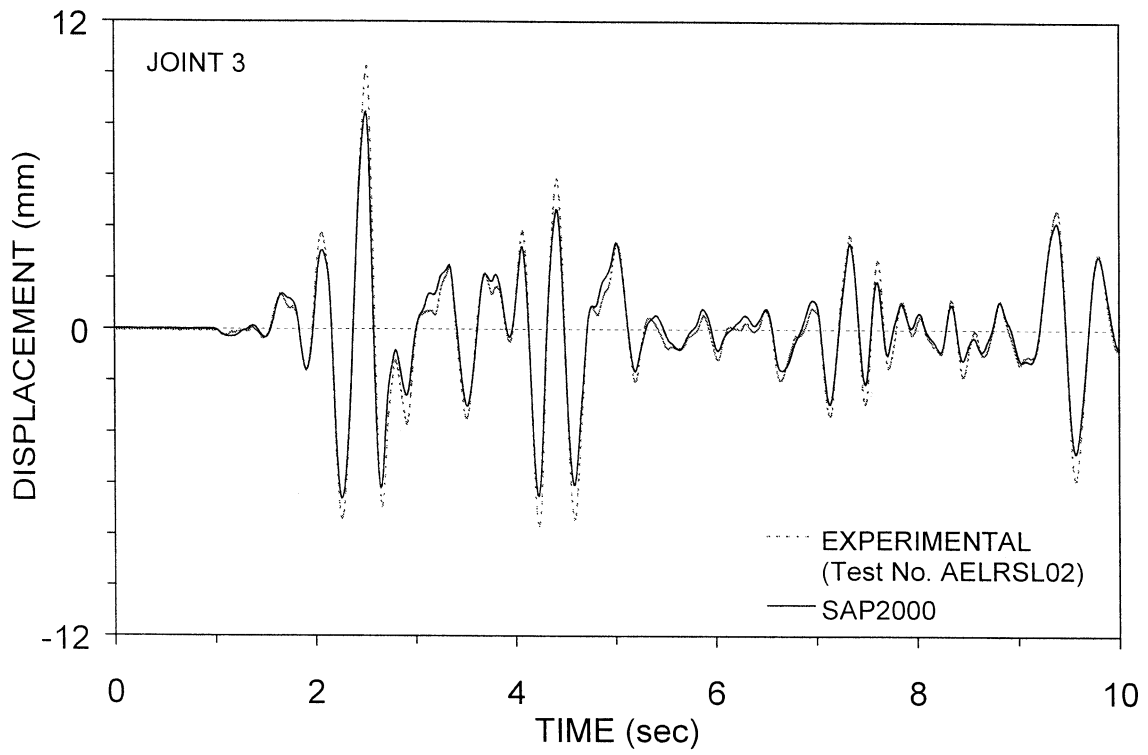


Figure 6-3 Schematic Illustrating Joints and Elements in ANSYS Model of Frame with Rigid-Simple Connections (for coordinates and section properties see Input File)

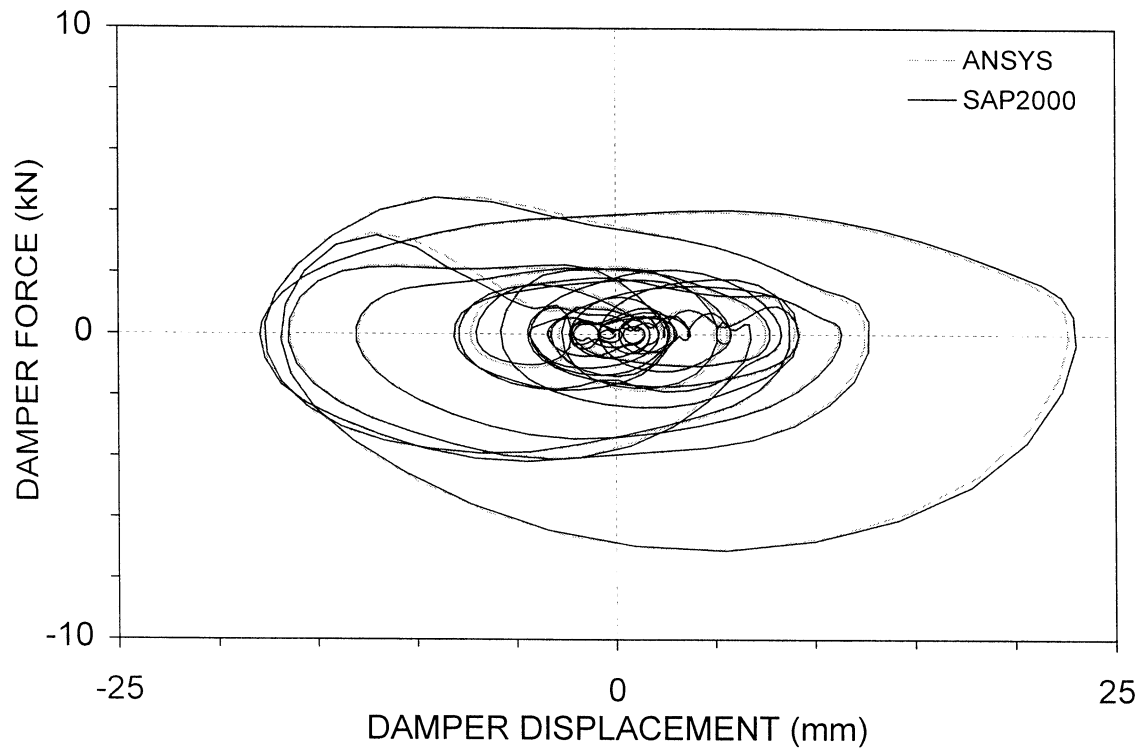
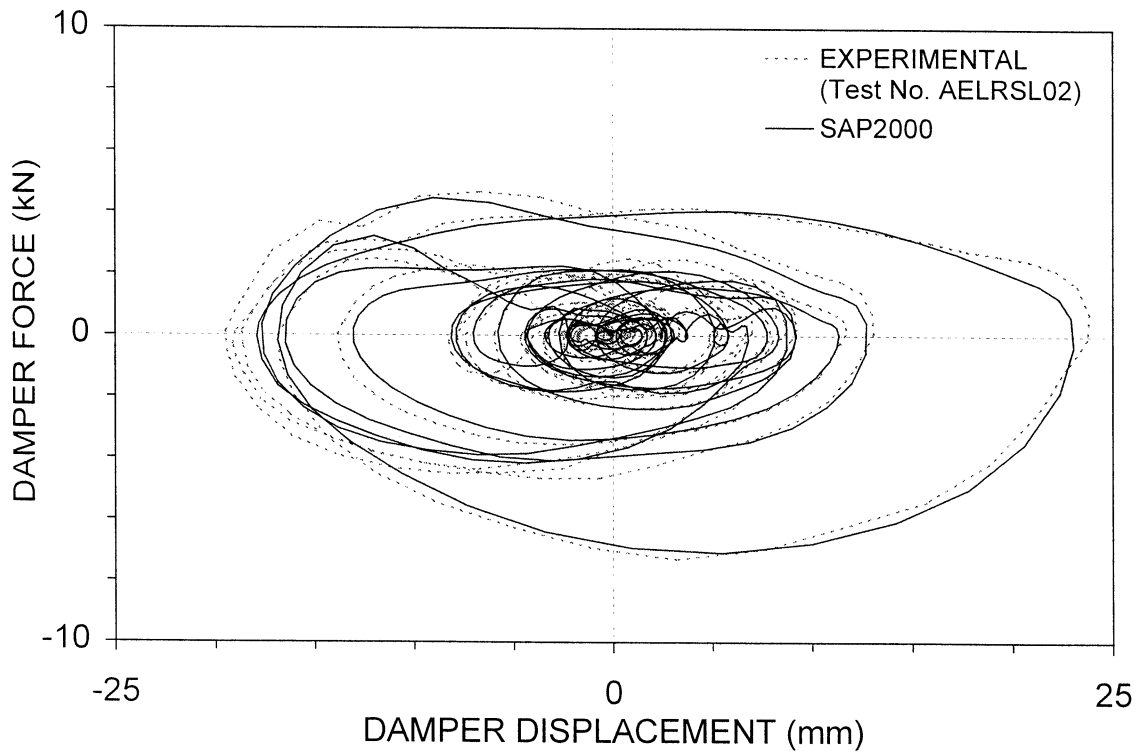


**Figure 6-4 Schematic Illustrating Location of Lumped Masses in ANSYS Model of Frame (values denote weight in pounds)**

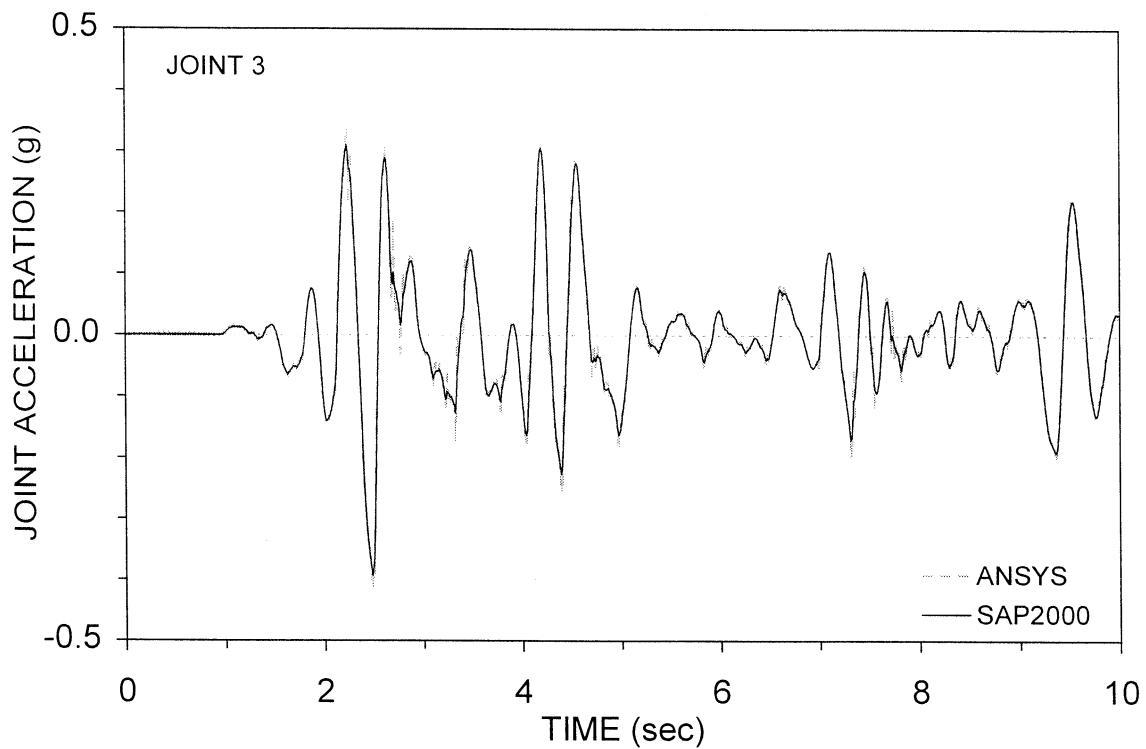
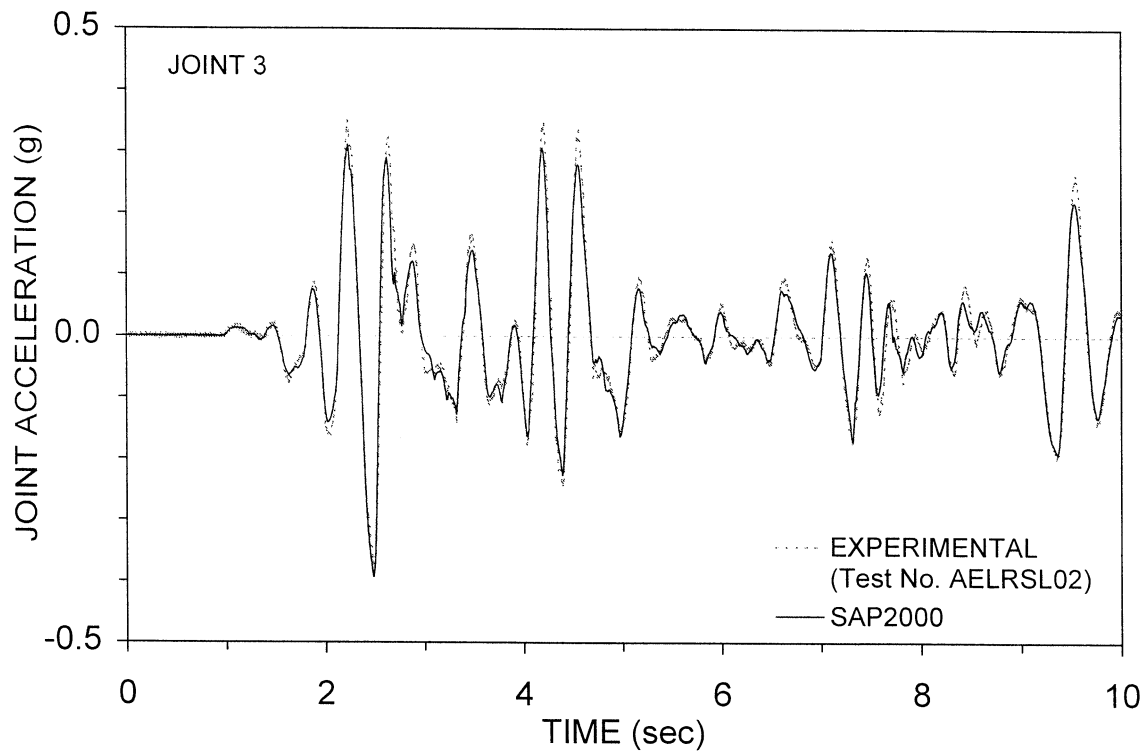
nearly identical results, which are in good agreement with the experimental response.



**Figure 6-5 Comparison of Analytical and Experimental Results on History of Frame Drift**



**Figure 6-6 Comparison of Analytical and Experimental Damper Force-Displacement Loops**



**Figure 6-7 Comparison of Analytical and Experimental Histories of Acceleration of Beam to Column Connection**





## SECTION 7

### CONCLUSIONS

A number of structures with seismic isolation and energy dissipation systems were modeled and analyzed using SAP2000, and the results were compared to either experimental results or to results obtained with programs 3D-BASIS-ME and ANSYS. In these examples, the element **Nlink** of SAP2000 in the **Isolator1**, the **Isolator2**, and the linear and nonlinear **damper** property configurations was tested. Input files for each example were provided and comments on the modeling were presented. Alternative modeling approaches and their effect on the calculated response were also presented.

In general, the use of SAP2000 produced results in excellent agreement with other programs and in good agreement with experimental results. This included the case of a tested isolated frame with uplifting Friction Pendulum bearings. However, modeling in SAP2000 was not always straightforward. Specifically, we made a number of observations in the behavior of the utilized elements, of which the following are of interest to users of this program:

- (a) For the **Isolator1** and **Isolator2** options of element **Nlink**, the linear effective stiffness for the shear degrees of freedom may have to be specified with a very small value rather than a realistic value.
- (b) The **Isolator2** option of element **Nlink**, which models Friction Pendulum bearings, may produce erroneous results unless it is combined with vertical linear damping elements to suppress fluctuations in the calculated forces resulting, likely, from numerical instability problems.

(c) There is a need to better describe the **damper** option of the **Nlink** element. As described in the manual of the program, this element is a Maxwell element. Yet, the element could be used to successfully describe behavior not possible for the Maxwell element and for the utilized combination of parameters (see Section 2).

Finally, there is a need to revisit the nonlinear viscous **damper** option of element **Nlink**. As described in Section 6, the use of this element did not produce accurate results in the analysis of a tested frame with nonlinear viscous dampers.

## SECTION 8

### REFERENCES


1. Al-Hussaini, T.M., Zayas, V. and Constantinou, M.C. (1994), "Seismic Isolation of Multi-Story Frame Structures Using Spherical Sliding Isolation Systems," Report No. NCEER-94-0007, National Center for Earthquake Engineering Research, Buffalo, New York.
2. Chung, L.L., Lin, R.C., Soong, T.T., and Reinhorn, A.M. (1988), "Experimental Study of Active Control of MDOF Structures Under Seismic Excitations," Report No. NCEER-88-0025. National Center for Earthquake Engineering Research, Buffalo, New York.
3. Computers and Structures, Inc., (1997), "SAP2000, Integrated Finite Element Analysis and Design of Structures", Version 6.1, Berkeley, CA.
4. Constantinou, M.C. and Symans, M.D. (1992), "Experimental and Analytical Investigation of Seismic Response of Structures with Supplemental Fluid Viscous Dampers," Report No. NCEER-92-0032, National Center for Earthquake Engineering Research, Buffalo, New York.
5. Constantinou, M.C., Tsopelas, P. and Hammel, W. (1997), "Testing and Modeling of an Improved Damper Configuration for Stiff Structural Systems", Technical Report of the Center for Industrial Effectiveness, University at Buffalo, State University of New York, Buffalo, NY, 14260.

6. Constantinou, M.C. (1998a), "Introduction to Passive Energy Dissipation", in Seminar Papers of 1998 Spring Seminar, Structural Engineers Association of Northern California, March.
7. Constantinou, M.C. (1998b), "Application of Seismic Isolation Systems in Greece", Proceedings of Structural Engineers World Congress, San Francisco, CA, July.
8. Hammel, W. (1997), "Testing and Modeling of an Improved Damper Configuration for Stiff Structural Systems," M.S. Thesis, University at Buffalo, State University of New York, Buffalo, NY 14260, August.
9. Haroun, M.A. and Housner, G.W. (1981), "Seismic Design of Liquid Storage Tanks", *J. Technical Councils*, ASCE, 107 (TCI), 191-207.
10. Hibbit, Karlsson and Sorensen, Inc., (1997) "ABAQUS/Standard, User's Manual", Version 5.7, Pawtucket, Rhode Island.
11. International Conference of Building Officials (1994), "Uniform Building Code", Whittier, CA.
12. Nagarajaiah, S., Reinhorn, A.M. and Constantinou, M.C. (1989), "Nonlinear Dynamic Analysis of Three-Dimensional Base Isolated Structures (3D-BASIS)", Report No. NCEER-89-0019, National Center for Earthquake Engineering Research, Buffalo, New York.
13. Reinhorn, A.M., Nagarajaiah, S., Constantinou, M.C., Tsopelas, P. and Li, R. (1994), "3-D-BASIS-TABS: Version 2.0 Computer Program for Nonlinear Dynamic Analysis of Three Dimensional Base Isolated Structures", Report No. NCEER-94-0018, National Center for Earthquake Engineering Research, Buffalo, New York.

14. Seleemah, A.A. and Constantinou, M.C. (1997), "Investigation of Seismic Response of Buildings with Linear and Nonlinear Fluid Viscous Dampers", Report No. NCEER-97-0004, National Center for Earthquake Engineering Research, Buffalo, New York.
15. Soong, T.T. and Constantinou, M.C (1994), "Passive and Active Structural Vibration Control in Civil Engineering", Springer-Verlag, Wien-New York.
16. Swanson Analysis Systems IP, Inc., (1996), "ANSYS, Finite Element Program and User's Manual", Version 5.3, Houston, PA.
17. Symans, M.D. and Constantinou, M.C. (1995), "Development and Experimental Study of Semi-Active Fluid Damping Devices for Seismic Protection of Structures", Report No. NCEER-95-0011, National Center for Earthquake Engineering Research, Buffalo, New York.
18. Theodossiou, D. and Constantinou, M.C. (1991), "Evaluation of SEAOC Design Requirements for Sliding Isolated Structures", Report No. NCEER-91-0015, National Center for Earthquake Engineering Research, Buffalo, New York.
19. Tsopelas, P.C., Constantinou, M.C. and Reinhorn, A.M. (1994), "3D-BASIS-ME: Computer Program for Nonlinear Dynamic Analysis of Seismically Isolated Single and Multiple Structures and Liquid Storage Tanks", Report No. NCEER-94-0010, National Center for Earthquake Engineering Research, Buffalo, New York.
20. Wilson, E.L, Hollings, J.P. and Dovey, H.H. (1975), "ETABS-Three Dimensional Analysis of Building Systems", Report No. UCB/EERC 75/13, Earthquake Engineering Research Center, University of California, Berkeley, CA.

21. Winters, C.W. and Constantinou, M.C. (1993), "Evaluation of Static and Response Spectrum Analysis Procedures of SEAOC/UBC for Seismic Isolated Structures", Report No. NCEER-93-0004, National Center for Earthquake Engineering Research, Buffalo, New York.





MULTIDISCIPLINARY CENTER FOR EARTHQUAKE ENGINEERING RESEARCH

*A National Center of Excellence in Advanced Technology Applications*

University at Buffalo, State University of New York  
Red Jacket Quadrangle ■ Buffalo, New York 14261-0025  
Phone: 716/645-3391 ■ Fax: 716/645-3399  
E-mail: [mceer@acsu.buffalo.edu](mailto:mceer@acsu.buffalo.edu) ■ WWW Site: <http://mceer.buffalo.edu>



University at Buffalo *The State University of New York*

ISSN 1520-295X