

NATIONAL CENTER FOR EARTHQUAKE
ENGINEERING RESEARCH

State University of New York at Buffalo

FUNDAMENTALS OF SYSTEM IDENTIFICATION IN STRUCTURAL DYNAMICS

by

H. Imai, C-B. Yun, O. Maruyama and M. Shinozuka

Department of Civil Engineering and Operations Research

Princeton University

Princeton, New Jersey 08544

Technical Report NCEER-89-0008

January 26, 1989

This research was conducted at Princeton University and was partially supported by the
National Science Foundation under Grant No. ECE 86-07591.

NOTICE

This report was prepared by Princeton University, Setsunan University, Korean Advanced Institute of Science and Technology, and Musashi Institute of Technology, as a result of research sponsored by the National Center for Earthquake Engineering Research (NCEER). Neither NCEER, associates of NCEER, its sponsors, Princeton University, Setsunan University, Korean Advanced Institute of Science and Technology, and Musashi Institute of Technology, nor any person acting on their behalf:

- a. makes any warranty, express or implied, with respect to the use of any information, apparatus, method, or process disclosed in this report or that such use may not infringe upon privately owned rights; or
- b. assumes any liabilities of whatsoever kind with respect to the use of, or the damage resulting from the use of, any information, apparatus, method or process disclosed in this report.

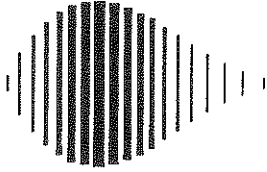

**FUNDAMENTALS OF SYSTEM IDENTIFICATION
IN STRUCTURAL DYNAMICS**

by

H. Imai,¹ C-B. Yun,² O. Maruyama³ and M. Shinozuka⁴

January 26, 1989

Technical Report NCEER-89-0008

NCEER Contract Number 87-3012 and 88-3011

NSF Master Contract Number ECE 86-07591

- 1 Professor of Mechanical Engineering, Setsunan University, Osaka, Japan
- 2 Professor of Civil Engineering, Korean Advanced Institute of Science and Technology, Seoul, South Korea
- 3 Research Associate, Department of Civil Engineering, Musashi Institute of Technology, Tokyo, Japan
- 4 Professor, Dept. of Civil Engineering and Operations Research, Princeton University

NATIONAL CENTER FOR EARTHQUAKE ENGINEERING RESEARCH
State University of New York at Buffalo
Red Jacket Quadrangle, Buffalo, NY 14261

PREFACE

The National Center for Earthquake Engineering Research (NCEER) is devoted to the expansion and dissemination of knowledge about earthquakes, the improvement of earthquake-resistant design, and the implementation of seismic hazard mitigation procedures to minimize loss of lives and property. The emphasis is on structures and lifelines that are found in zones of moderate to high seismicity throughout the United States.

NCEER's research is being carried out in an integrated and coordinated manner following a structured program. The current research program comprises four main areas:

- Existing and New Structures
- Secondary and Protective Systems
- Lifeline Systems
- Disaster Research and Planning

This technical report pertains to Program 3, Lifeline Systems, and more specifically to water delivery systems.

The safe and serviceable operation of lifeline systems such as gas, electricity, oil, water, communication and transportation networks, immediately after a severe earthquake, is of crucial importance to the welfare of the general public, and to the mitigation of seismic hazards upon society at large. The long-term goals of the lifeline study are to evaluate the seismic performance of lifeline systems in general, and to recommend measures for mitigating the societal risk arising from their failures.

From this point of view, Center researchers are concentrating on the study of specific existing lifeline systems, such as water delivery and crude oil transmission systems. The water delivery system study consists of two parts. The first studies the seismic performance of water delivery systems on the west coast, while the second addresses itself to the seismic performance of the water delivery system in Memphis, Tennessee. For both systems, post-earthquake fire fighting capabilities will be considered as a measure of seismic performance.

The components of the water delivery system study are shown in the accompanying figure.

Program Elements:

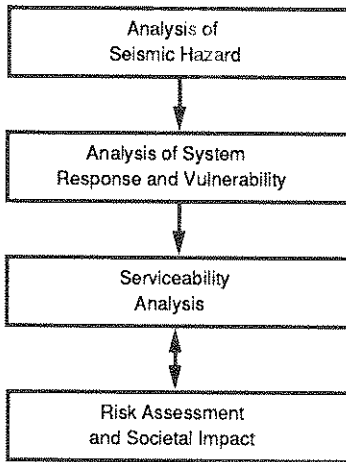

Tasks:

Wave Propagation, Fault Crossing
Liquefaction and Large Deformation
Above- and Under-ground Structure Interaction
Spatial Variability of Ground Motion

Soil-Structure Interaction, Pipe Response Analysis
Statistics of Repair/Damage
Post-Earthquake Data Gathering Procedure
Leakage Tests, Centrifuge Tests for Pipes

Post-Earthquake Firefighting Capability
System Reliability
Computer Code Development and Upgrading
Verification of Analytical Results

Mathematical Modeling
Socio-Economic Impact

In estimating the dynamic characteristics of existing structures and in assessing their seismic performance, it often becomes necessary to identify the parameters of the mathematical models used for such estimation and assessment.

Examined in this study are the methods of such parameter identification for structural dynamic systems relevant to the linear and nonlinear behavior of structures subjected to such environmental loads as ground motion due to earthquakes, wind-generated pressure and wind-induced ocean wave forces. Emphasis is placed on those methods that can be used in on-line field experiment situations. These methods include the least squares, instrumental variable, maximum likelihood and a method utilizing the extended Kalman filter. In order to verify the validity of these methods, numerical simulation studies are carried out utilizing mathematical models of a suspension bridge, offshore tower and building structure. On the basis of such simulation studies, the efficiency of these methods is investigated under several conditions of observational noise.

ABSTRACT

Examined in this study are methods of identification for structural dynamic systems relevant to the linear and nonlinear behavior of structures subjected to such environmental loads as ground motion due to earthquakes, wind-generated pressure and wind-induced ocean wave forces. Emphasis is placed on those methods that can be used in on-line field experiment situations. These methods include the least squares, instrumental variable, maximum likelihood and a method utilizing the extended Kalman filter. In order to verify the validity of these methods, numerical simulation studies are carried out utilizing mathematical models of a suspension bridge, offshore tower and building structure. On the basis of such simulation studies, the efficiency of these methods are investigated under several conditions of observational noise.

ACKNOWLEDGEMENT

This work was supported by the National Center for Earthquake Engineering under grant numbers 87-3012 and 88-3011 under the auspices the National Science Foundation, master contract number ECE-86-07591.

TABLE OF CONTENTS

Section	page
1 Introduction	1-1
2 Structural System and Mathematical Model	2-1
3 Algorithms for Parameter Estimation	3-1
3.1 Least Squares Method	3-1
3.2 Maximum Likelihood Method	3-3
3.3 Extended Kalman Filter	3-4
4 Numerical Examples and Discussion	4-1
4.1 Suspension Bridge Model	4-1
4.2 Offshore Structure	4-6
4.3 Structure with Bilinear Hysteresis	4-7
4.4 Identification of Equivalent Linear System	4-20
5 Conclusions	5-1
6 References	6-1

LIST OF TABLES

Table	page
4-I Exact and Estimated Parameters of Suspension Bridge	4-2
4-II Exact and Estimated Parameters of Offshore Structure Model	4-8
4-III Exact and Estimated Parameters of Structure with Bilinear Hysteresis	4-14
4-IV Estimated Parameters of Equivalent Linear System	4-23

LIST OF FIGURES

Figure	page
2-1 Shear Beam Structure Model of Multistory Building	2-2
2-2 Bridge Deck Model	2-4
2-3 Fixed Offshore Tower and Model	2-6
4-1 Simulated Time Histories of Wind Velocity Fluctuations	4-3
4-2 Time Histories of Observation $Y_h(t)$ and Estimated Responses $\bar{h}(t)$ for Heaving Motion of Suspension Bridge	4-4
4-3 Time Histories of Observation $Y_\alpha(t)$ and Estimated Response $\bar{\alpha}(t)$ for Pitching Motion of Suspension Bridge	4-5
4-4 Simulated Time Histories of Wave Particle Velocities and Accelerations	4-9
4-5 Exact, Observed and Estimated Responses of Offshore Structures	4-10
4-6 Estimated Parameters of Offshore Structure as Augmented State Variable	4-12
4-7 Bilinear Hysteresis	4-15
4-8 Input Ground Acceleration	4-16
4-9 Observed and Estimated Displacement of Structure	4-17
4-10 Observed and Estimated Velocity of Structure	4-18
4-11 True and Estimated Hystereses	4-19
4-12 Exact and Estimated Displacement of Offshore Structure	4-24

SECTION 1 INTRODUCTION

This study examines existing methods of system identification relevant to the dynamic behavior of structures under various environmental loads. The problem of system identification has become increasingly important in the area of structural engineering, particularly in connection with the prediction of structural response to adverse environmental loadings such as earthquakes, wind and wave forces (Shinozuka, Yun and Imai, 1982; Yun and Shinozuka, 1980; Hoshiya and Maruyama, 1987; Paliou and Shinozuka, 1988) and also with respect to estimation of the existing conditions of structures for the assessment of damage and deterioration (Natke and Yao, 1986; Hoshiya and Maruyama, 1987; Chen and Garba, 1987; DiPasquale and Cakmak, 1987).

The general subjects of system identification originally began in the area of electrical engineering and later extended to the field of mechanical/control engineering. Various techniques have been developed. One can find general surveys on the subject in Hart and Yao (1977), IFAC Symposium (1982), Kozin and Natke (1986) and Ljung (1987). However, those methods available may not be readily or directly applicable to problems of structural engineering systems for the following reasons: (i) structural systems are generally much larger in size and much more complex in behavior so that accurate mathematical idealization is not easy, (ii) the availability of options for input-output observational data is usually limited, (iii) observational data are generally heavily contaminated by measurement noise, and (iv) in the case of a damaged or deteriorated system, the behavior may be highly nonlinear. Therefore, for the purpose of effective structural engineering applications, specialized techniques of system identification need to be developed.

In general, system identification methods are classified as parametric and nonparametric. Parametric identification involves estimation of system parameters, while nonparametric identification determines the transfer function of the system in terms of analytical representation. Identification methods can also be categorized as those in the time domain and the frequency domain. In the time domain method, system parameters are determined from observational data sampled in time. On the other hand, in the frequency domain method, modal quantities such as natural frequencies, damping ratio and modal shapes are identified using measurements in the frequency domain. In the present study, mainly parametric identification techniques in the time domain are investigated, since it is more relevant to the identification of structural parameters related to environmental loading and/or nonlinear behavior.

In Section 2, methods for modeling structural systems are discussed with in the context of system identification. In Section 3, several identification techniques based on least squares, maximum likelihood and extended Kalman filter are described. In Section 4, numerical simulation analyses are given for different structural systems, i.e., a suspension bridge, offshore structure and structure with nonlinear hysteresis. The efficiency of various identification methods is investigated under various noise conditions. One of these simulation analyses is unique in that the method for system identification is applied to obtain an equivalent linear system representing a nonlinear offshore structure. The result obtained by this new method of identifying the equivalent linear system has been compared with those of conventional methods.

Computer programs have been developed for the various system identification methods discussed in this study and used for example studies. Documentation of these programs is currently underway and will be made available in the near future. Presently, an experimental study is also being carried out using

laboratory models in order to verify the validity of the identification techniques demonstrated in this study. Upon such verification, field experiments will follow. The results of these experimental studies will also be reported in the near future.

SECTION 2

STRUCTURAL SYSTEM AND MATHEMATICAL MODEL

Civil engineers deal with many types of structural dynamic systems: for example, multi-story buildings, suspension bridges, nuclear power plants, offshore structures, etc. The dynamic characteristics of these structures can be described by mathematical models. A variety of models have been developed for different purposes. Models commonly used in structural and system engineering are the following:

1. ordinary differential equation (ODE)
2. transfer function
3. state space model
4. ARMAX model

In the following, it is shown that most of the structural systems can be modeled by means of ordinary differential equations (ODE) and that the remaining three models are derived from the ordinary differential equation.

Example 1: Multi-story building (e.g., Shinozuka, Itagaki and Hakuno, 1968)

Assuming a shear building model, an n-story building can be modeled as shown in Fig. 2-1. The equation of motion of this structure under ground excitation is written as:

$$m_i \ddot{\xi}_i + c_i (\dot{\xi}_i - \dot{\xi}_{i-1}) - c_{i+1} (\dot{\xi}_{i+1} - \dot{\xi}_i) + k_i (\xi_i - \xi_{i-1}) - k_{i+1} (\xi_{i+1} - \xi_i) = -m_i \ddot{x}_g \quad (i=1,2,\dots,n) \quad (2-1)$$

where ξ_i , $\dot{\xi}_i$ and $\ddot{\xi}_i$ are the relative horizontal displacement, velocity and acceleration of the i-th floor to the ground, \ddot{x}_g is the horizontal ground acceleration, and m_i , c_i , k_i are the mass, damping, stiffness coefficients,

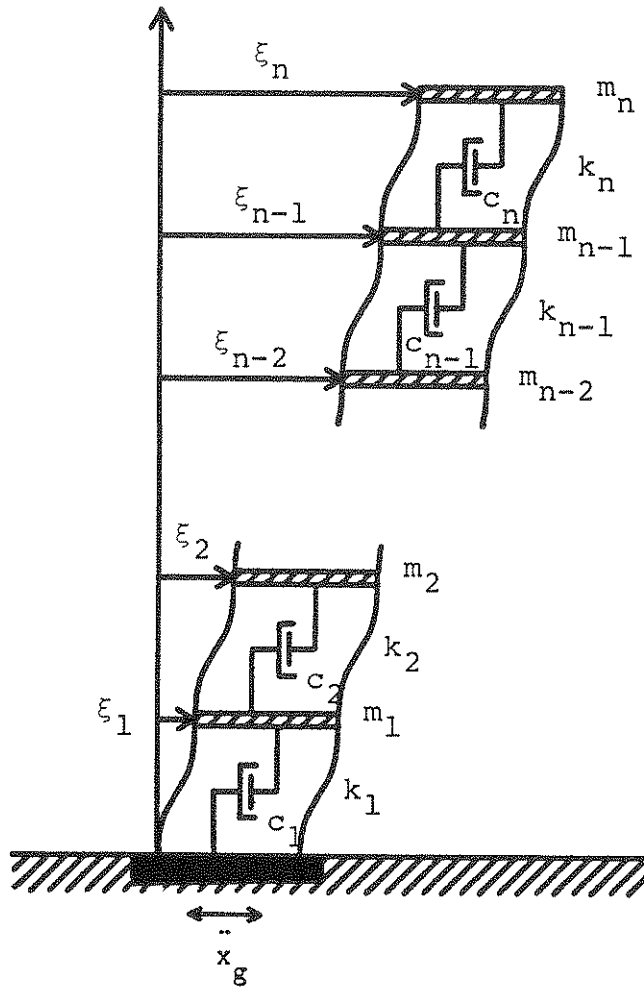

FIGURE 2-1 Shear Beam Structure Model of Multistory Building

respectively.

In vector-matrix notation, Eq. 2-1 can be written as follows:

$$\mathbf{M}\ddot{\mathbf{z}} + \mathbf{C}\dot{\mathbf{z}} + \mathbf{K}\mathbf{z} = \mathbf{L}u \quad (2-2)$$

where $\mathbf{z} = [\xi_1 \ \xi_2 \ \dots \ \xi_n]^T$ and $u = -\ddot{x}_g$. \mathbf{M} is an $n \times n$ diagonal matrix with $M_{ii} = m_i$. \mathbf{L} is an $n \times 1$ matrix with $L_i = m_i$. \mathbf{C} and \mathbf{K} are both $n \times n$ symmetric matrices as

$$\mathbf{C} = \begin{bmatrix} c_1 + c_2 & -c_2 & 0 & \dots & \dots & 0 \\ -c_2 & c_2 + c_3 & -c_3 & \dots & \dots & 0 \\ 0 & -c_3 & c_3 + c_4 & \dots & \dots & 0 \\ \vdots & \vdots & \vdots & \ddots & \vdots & \vdots \\ \dots & \dots & \dots & \dots & c_{N-1} + c_N & -c_{N-1} \\ 0 & 0 & 0 & \dots & -c_{N-1} & c_N \end{bmatrix} \quad (2-3)$$

$$\mathbf{K} = \begin{bmatrix} k_1 + k_2 & -k_2 & 0 & \dots & \dots & 0 \\ -k_2 & k_2 + k_3 & -k_3 & \dots & \dots & 0 \\ 0 & -k_3 & k_3 + k_4 & \dots & \dots & 0 \\ \vdots & \vdots & \vdots & \ddots & \vdots & \vdots \\ \dots & \dots & \dots & \dots & k_{N-1} + k_N & -k_{N-1} \\ 0 & 0 & 0 & \dots & -k_{N-1} & k_N \end{bmatrix} \quad (2-4)$$

Example 2: Suspension bridge (e.g., Shinozuka, Yun and Imai, 1982)

To investigate the dynamic characteristics of a suspension bridge such as aerodynamic instability, an idealized two-dimensional model of the bridge section as shown in Fig. 2-2 is frequently employed. The equation of motion of the model can be expressed as

$$\mathbf{M}\ddot{\mathbf{z}} + \mathbf{C}\dot{\mathbf{z}} + \mathbf{K}\mathbf{z} = \mathbf{L}f \quad (2-5)$$

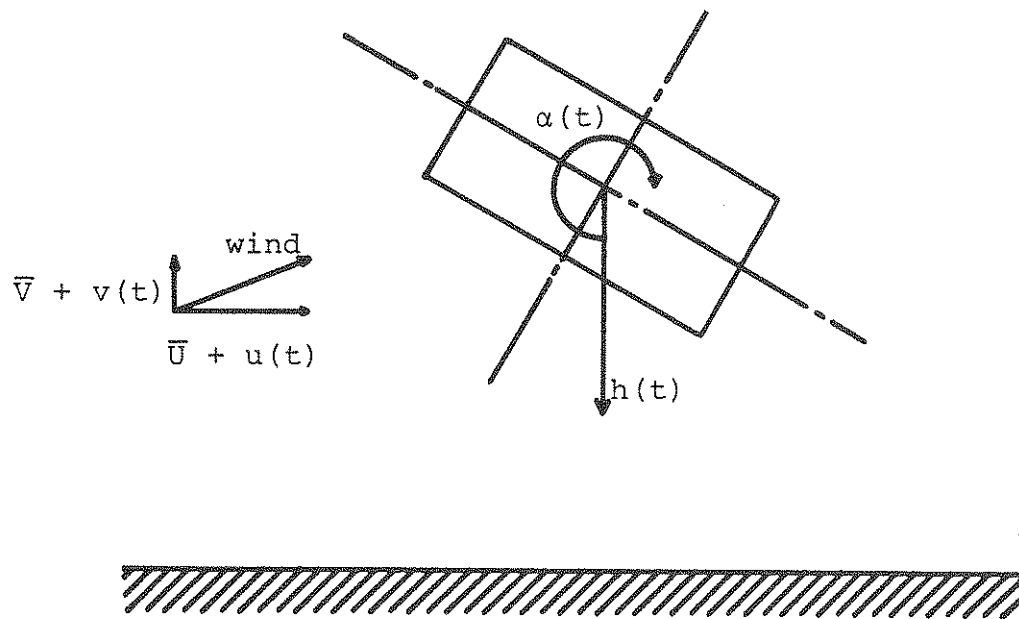

FIGURE 2-2 Bridge Deck Model

where $\mathbf{z} = \{h, \alpha\}^T$, $\mathbf{f} = \{u, v\}^T$ with α = pitching motion, h = heaving motion, and u and v = fluctuating components of the wind velocity in the horizontal and vertical directions, respectively. \mathbf{M} is the mass matrix. \mathbf{C} and \mathbf{K} are the damping and stiffness matrices including the aerodynamic effects.

Example 3: Offshore structure (e.g., Yun and Shinozuka, 1980; Paliou and Shinozuka, 1988)

An idealized model for the dynamic analysis of an offshore structure is shown in Fig. 2-3. The equation of motion of the structure is written by

$$(\mathbf{M}_0 + \mathbf{C}_M)\ddot{\mathbf{z}} + \mathbf{C}\dot{\mathbf{z}} + \mathbf{K}_0\mathbf{z} = \mathbf{C}_M\ddot{\mathbf{v}} + \mathbf{C}_D(\dot{\mathbf{v}} - \dot{\mathbf{z}})|\dot{\mathbf{v}} - \dot{\mathbf{z}}| \quad (2-6)$$

where \mathbf{z} is the vector of horizontal displacement, $\dot{\mathbf{v}}$, $\ddot{\mathbf{v}}$ are the vector of horizontal wave particle velocity and acceleration, \mathbf{M}_0 , \mathbf{C} , \mathbf{K}_0 are the matrices of structural mass, damping, and stiffness, and \mathbf{C}_M and \mathbf{C}_D are diagonal matrices containing, respectively, the inertia and drag coefficients associated with the wave force acting on the structure.

In the case of linear structural systems as in Example 1, the equation of motion can also be represented by using the transfer function as

$$\mathbf{Z}(s) = \mathbf{G}(s)\mathbf{U}(s) \quad (2-7)$$

$$\mathbf{G}(s) = (\mathbf{M}s^2 + \mathbf{C}s + \mathbf{K})^{-1}\mathbf{L} \quad (2-8)$$

where $\mathbf{Z}(s)$, $\mathbf{U}(s)$ are the Laplace transforms of $\mathbf{z}(t)$ and $\mathbf{u}(t)$, and $\mathbf{G}(s)$ is the transfer function of the system.

The state space model in continuous form can be derived for linear and nonlinear systems. For example, by defining the state vector as

$$\mathbf{x} = \begin{matrix} x_1 \\ x_2 \end{matrix} = \begin{matrix} \mathbf{z} \\ \dot{\mathbf{z}} \end{matrix} \quad (2-9)$$

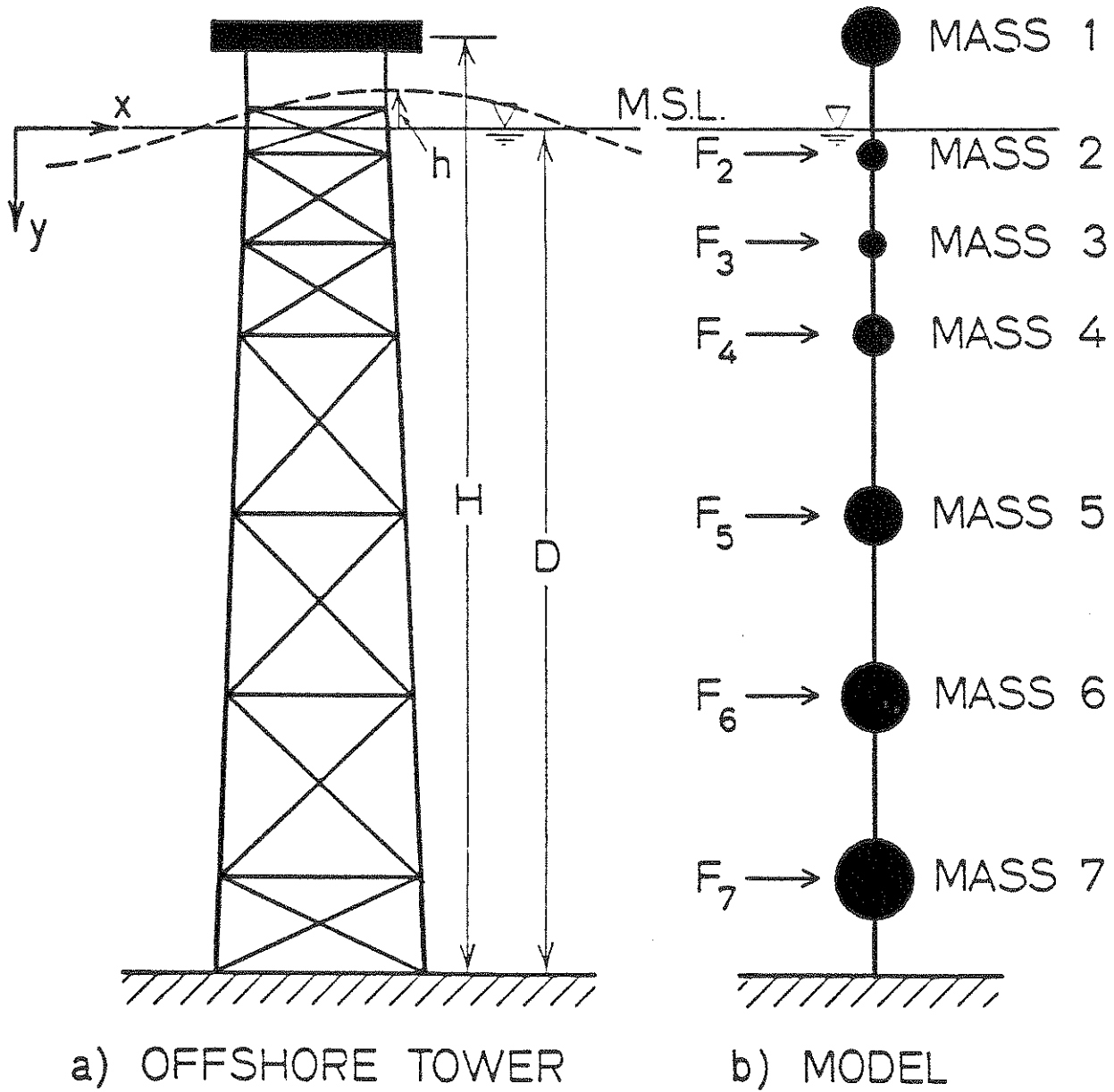

FIGURE 2-3 Fixed Offshore Tower and Model

Equation 2-2 can be transformed into a state equation as

$$\begin{aligned} \begin{matrix} \dot{x}_1 \\ \dot{x}_2 \end{matrix} &= \{f(x_1, x_2, u)\} + w \\ &= \begin{matrix} x_2 \\ -M^{-1}Kx_1 - M^{-1}Cx_2 + M^{-1}Lu \end{matrix} + \begin{matrix} 0 \\ M^{-1} \end{matrix} \zeta \end{aligned} \quad (2-10)$$

where w and ζ are system noises which account for the unmeasurable input disturbances and errors in modelling.

If the system is linear as in Eq. 2-2, Eq. 2-10 can be rewritten as

$$\dot{x} = Ax + Bu + Dz \quad (2-11)$$

where

$$A = \begin{matrix} 0 & I \\ -M^{-1}K & -M^{-1}C \end{matrix}, \quad B = \begin{matrix} 0 \\ M^{-1}L \end{matrix}, \quad D = \begin{matrix} 0 \\ M^{-1} \end{matrix}$$

The measurement y of the output z may be subjected to a measurement noise v , i.e.,

$$y = z + v = Hx + v \quad (2-12)$$

where $H = [I, 0]$. The set of Eqs. 2-11 and 2-12 is called the state-space model in continuous form. Usually, ζ and v are assumed to be white noise vectors with zero mean and variance Q and R , respectively.

In recent years, most signal processing is accomplished by digital computers which cannot handle continuous time signals. Therefore, the output signal has to be in discrete form ($t=0, \Delta t, 2\Delta t, \dots$) where Δt denotes the sampling interval. Thus, for a linear system, the state space model is discretized as follows (e.g., Shinozuka, Yun and Imai, 1982)

$$\mathbf{x}(i+1) = \mathbf{F}\mathbf{x}(i) + \mathbf{G}\mathbf{u}(i) + \mathbf{w}(i) \quad (2-13)$$

$$\mathbf{y}(i) = \mathbf{H}\mathbf{x}(i) + \mathbf{v}(i) \quad (2-14)$$

where

$$\mathbf{F} = e^{\mathbf{A}\Delta t}, \quad \mathbf{G} = \left[\int_0^{\Delta t} e^{\mathbf{A}\tau} d\tau \right] \mathbf{B}$$

and

$$\mathbf{x}(i) \equiv \mathbf{x}(i\Delta t), \quad \mathbf{y}(i) \equiv \mathbf{y}(i\Delta t), \quad \mathbf{u}(i) \equiv \mathbf{u}(i\Delta t), \quad \mathbf{v}(i) \equiv \mathbf{v}(i\Delta t)$$

where it is assumed that the input $\mathbf{u}(t)$ is piecewise constant within each sampling interval, i.e.

$$\mathbf{u}(t) = \mathbf{u}(i\Delta t), \quad i\Delta t \leq t < (i+1)\Delta t \quad (2-15)$$

The system noise $\mathbf{w}(i)$ which is defined by

$$\mathbf{w}(i) = \int_{i\Delta t}^{(i+1)\Delta t} e^{\mathbf{A}[(i+1)\Delta t - \tau]} \mathbf{D}\zeta(\tau) d\tau \quad (2-16)$$

is a white noise sequence with zero mean and the covariance matrix

$$\mathbf{Q}_w = E[\mathbf{w}(i)\mathbf{w}^T(i)] = \int_0^{\Delta t} e^{\mathbf{A}\tau} \mathbf{D}\mathbf{Q}\mathbf{D}^T [e^{\mathbf{A}\tau}]^T d\tau \quad (2-17)$$

The state space model may also be represented in innovation form (Ljung and Söderström, 1983), i.e.

$$\mathbf{x}(i+1) = \mathbf{F}\mathbf{x}(i) + \mathbf{G}\mathbf{u}(i) + \mathbf{\Gamma}\mathbf{e}(i) \quad (2-18)$$

$$\mathbf{y}(i) = \mathbf{H}\mathbf{x}(i) + \mathbf{e}(i) \quad (2-19)$$

where $\mathbf{x}(i)$ is the estimation at $t = i\Delta t$, $\mathbf{\Gamma}$ is the so-called steady state Kalman gain and $\mathbf{e}(i)$ the innovation process. The innovation model is preferable over the general state-space model, since it has fewer parameters than the latter.

When the system is controllable and observable, we can eliminate $\mathbf{x}(i)$ from Eqs. 2-18 and 2.19 to obtain the following ARMAX model (e.g., Shinozuka, Yun and Imai, 1982; Ljung and Söderström, 1983)

$$\begin{aligned} \mathbf{y}(i) = & \mathbf{F}_1 \mathbf{y}(i-1) + \mathbf{F}_2 \mathbf{y}(i-2) + \mathbf{G}_1 \mathbf{u}(i-1) + \mathbf{G}_2 \mathbf{u}(i-2) \\ & + \mathbf{e}(i) + \mathbf{J}_1 \mathbf{e}(i-1) + \mathbf{J}_2 \mathbf{e}(i-2) \end{aligned} \quad (2-20)$$

If the measurable input $\mathbf{u}(\cdot)$ is missing, the model is called an ARMA model.

The mathematical models introduced above are used for different purposes. For conventional problems of the analysis and design of a structural system, ordinary differential equations and transfer functions have commonly been used for a long time. For the identification of modal quantities, the transfer function has been also widely employed. However, as for the identification of structural parameters, state space equations and ARMAX models are preferable because the identification techniques recently developed are based on sampled data in time.

SECTION 3

ALGORITHMS FOR PARAMETER ESTIMATION

Many different algorithms of parameter estimation exist. The most commonly used algorithms are least squares method, maximum likelihood method, extended kalman filter, and their variations, which are briefly discussed in the following.

3.1 Least Squares Method (Eykhoff, 1974; Shinozuka, Yun and Imai, 1982; Ljung, 1987)

Consider a system described by an ARMAX model (Eq. 2.20), and define the equation error vector as

$$\epsilon(i) = e(i) + J_1 e(i-1) + J_2 e(i-2) \quad (3.1.1)$$

Then Eq. 2.20 can be rewritten as

$$y(i) = F_1 y(i-1) + F_2 y(i-2) + G_1 u(i-1) + G_2 u(i-2) + \epsilon(i) \quad (3.1.2)$$

The least squares method is based on minimization of

$$\begin{aligned} J &= \sum_{i=3}^N \epsilon(i)^T \epsilon(i) = \sum_{i=3}^N ||\epsilon(i)||^2 \\ &= \sum_{i=3}^N ||y(i) - F_1 y(i-1) - F_2 y(i-2) - G_1 u(i-1) - G_2 u(i-2)||^2 \end{aligned} \quad (3.1.3)$$

with respect to

$$\theta = [F_1, F_2, G_1, G_2]^T \quad (3.1.4)$$

where N is the number of data points.

To solve the minimization problem, one may define a vector $\psi(i)$ and matrices Y and Ψ as

$$\psi(i) = [\mathbf{y}(i-1)^T, \mathbf{y}(i-2)^T, \mathbf{u}(i-1)^T, \mathbf{u}(i-2)^T]^T \quad (3.1.5)$$

$$\mathbf{Y} = [\mathbf{y}(3), \mathbf{y}(4), \dots, \mathbf{y}(N)]^T \quad (3.1.6)$$

$$\Psi = [\psi(3), \psi(4), \dots, \psi(N)]^T \quad (3.1.7)$$

Then, Eq. 3.1.2 can be rewritten as

$$\mathbf{y}(i) = \Theta^T \psi(i) + \epsilon(i) \quad \text{for } i=3,4,\dots,N \quad (3.1.8)$$

and further into matrix form as

$$\mathbf{Y} = \Psi \Theta + [\epsilon(3), \epsilon(4), \dots, \epsilon(N)]^T \quad (3.1.9)$$

Then, from Eq. 3.1.9, the least squares estimate Θ which minimizes Eq. 3.1.3 can be obtained as

$$\Theta_{LS} = [\Psi^T \Psi]^{-1} [\Psi^T \mathbf{Y}] \quad (3.1.10)$$

It is noted that, in general, the least squares estimate is biased; i.e., Θ_{LS} does not converge to the true value Θ as N approaches infinity. This is a major drawback of the least squares method. To overcome this difficulty, several improved methods have been developed. Among them, an instrumental variable method (Wong and Polack, 1967; Eykhoff, 1974) and a generalized least squares method (Astrom and Eykhoff, 1971; Goodwin and Payne, 1977) should be mentioned.

The least squares method is also available in sequential form (Ljung and Söderström, 1983). Let θ_i denote an estimate of θ based on the data $\{\mathbf{y}(1), \mathbf{y}(2), \dots, \mathbf{y}(i), \mathbf{u}(1), \dots, \mathbf{u}(i)\}$, then θ_i can be estimated sequentially by

$$\theta_i = \theta_{i-1} + K_i (\mathbf{y}^T(i) - \psi_i^T(i) \theta_{i-1}) \quad (3.1.11)$$

where

$$K_i = P_{i-1} \psi(i) (1 + \psi^T(i) P_{i-1} \psi(i))^{-1} \quad (3.1.12)$$

$$P_i = P_{i-1} - P_{i-1} \psi(i) (1 + \psi^T(i) P_{i-1} \psi(i))^{-1} \psi^T(i) P_{i-1} \quad (3.1.13)$$

and where the initial values θ_0 , P_0 , $\psi(1)$ should be given a priori.

3.2 Maximum Likelihood Method (Astrom and Eykhoff, 1971; Eykhoff, 1974; Shinozuka, Yun and Imai, 1982; Ljung, 1987)

Let $P(\mathbf{y}|\mathbf{u},\theta)$ denote the conditional probability density, where $\mathbf{u} = [\mathbf{u}(1), \mathbf{u}(2), \dots, \mathbf{u}(N)]^T$. For a given set of data $[\mathbf{y},\mathbf{u}]$, one may construct the likelihood function as $\log P(\mathbf{y}|\mathbf{u},\theta)$ which is a function of θ ,

$$L = \log P(\mathbf{y}|\mathbf{u},\theta) \quad (3.2.1)$$

An estimate which maximizes the likelihood function of θ is called the maximum likelihood estimate and denoted by θ_{ML} .

As for the linear discrete-time system, the maximization of Eq. 3.2.1 corresponds to the minimization (Kashyap, 1970) of

$$J = \det \left[\sum_{i=1}^N \mathbf{e}(i) \mathbf{e}^T(i) \right] \quad (3.2.2)$$

where $\mathbf{e}(i)$ is a one step ahead prediction error which is defined by

$$\mathbf{e}(i) = \mathbf{y}(i) - \mathbf{y}(i|i-1) \quad (3.2.3)$$

and

$$\mathbf{y}(i|i-1) = E\{\mathbf{y}(i)|\mathbf{y}(1), \mathbf{y}(2), \dots, \mathbf{y}(i-1), \mathbf{u}(1), \mathbf{u}(2), \dots, \mathbf{u}(i-1), \theta\} \quad (3.2.4)$$

The prediction error $\mathbf{e}(i)$ can be computed sequentially according to

$$\mathbf{e}(1) = \mathbf{y}(1)$$

$$\begin{aligned}
\mathbf{e}(2) &= \mathbf{y}(2) - \mathbf{F}_1 \mathbf{y}(1) - \mathbf{G}_1 \mathbf{u}(1) - \mathbf{J}_1 \mathbf{e}(1) \\
\mathbf{e}(i) &= \mathbf{y}(i) - \mathbf{F}_1 \mathbf{y}(i-1) - \mathbf{F}_2 \mathbf{y}(i-2) - \mathbf{G}_1 \mathbf{u}(i-1) - \mathbf{G}_2 \mathbf{u}(i-2) - \mathbf{J}_1 \mathbf{e}(i-1) - \mathbf{J}_2 \mathbf{e}(i-2) \\
& \qquad \qquad \qquad i = 3, 4, \dots, N \qquad (3.2.5)
\end{aligned}$$

The problem of minimization of Eq. 3.2.2 may not be solved analytically in general. Thus nonlinear programming algorithms have to be used, e.g., Newton-Raphson method, Davidson method (Dahlquist and Björck, 1974), etc. While the maximum likelihood estimate has a nice property that it is consistent and asymptotically efficient, it usually requires a substantial amount of computational time. To circumvent this disadvantage, several approximate methods are proposed, e.g., recursive maximum likelihood method (Gertler and Bányász, 1974), approximate maximum likelihood method (Goodwin and Payne, 1977), etc. Most of them are given in sequential form.

3.3 Extended Kalman Filter (Goodwin and Payne, 1977; Yun and Shinozuka 1980; Ljung, 1987)

The basic algorithm of the extended Kalman filter is a recursive process for estimating the optimal state of a nonlinear system based on observed data for the input (excitation) and output (response). It can be summarized as follows. Consider a general continuous state equation described by

$$\dot{\mathbf{X}}(t) = \mathbf{g}(\mathbf{X}, \mathbf{u}; t) + \mathbf{w}(t) \qquad (3.3.1)$$

with observation at $t = k\Delta t$

$$\mathbf{y}(k) = \mathbf{H}\mathbf{X}(k) + \mathbf{v}(k) \qquad (3.3.2)$$

in which $\mathbf{X}(k)$ = state vector at $t = k\Delta t$, $\mathbf{y}(k)$ = observational vector at $t = k\Delta t$, $\mathbf{v}(k)$ = observational noise vector with covariance of \mathbf{V}_v , $\mathbf{w}(t)$ = system noise vector with covariance of \mathbf{V}_w and \mathbf{H} = matrix associated with observa-

tions.

The predicted state $\mathbf{X}(k+1/k)$ and its error covariance matrix $\mathbf{P}(k+1/k)$ can be evaluated as

$$\begin{aligned}\mathbf{X}(k+1/k) &= E\{\mathbf{X}(k+1) | \mathbf{y}(1), \mathbf{y}(2), \dots, \mathbf{y}(k)\} \\ &= \mathbf{X}(k/k) + \int_{k\Delta t}^{(k+1)\Delta t} \mathbf{g}(\mathbf{X}(t/k), \mathbf{u}; t) dt\end{aligned}\quad (3.3.3)$$

$$\mathbf{P}(k+1/k) = \Phi(k+1, k)\mathbf{P}(k/k)\Phi^T(k+1, k) + \mathbf{V}_w \quad (3.3.4)$$

where $E\{A|B\}$ is the expected value of A conditional to B and $\Phi(k+1, k)$ is the state transition matrix which can be approximately obtained as

$$\Phi(k+1, k) \approx \mathbf{I} + \Delta t \left[\frac{\partial \mathbf{g}_i(\mathbf{X}(t), t)}{\partial \mathbf{X}_j} \right]_{\mathbf{X}(t) = \mathbf{X}(k/k)} \quad (3.3.5)$$

for small Δt .

Then, the filtered state $\mathbf{X}(k+1/k+1)$ and its error covariance matrix $\mathbf{P}(k+1/k+1)$ can be estimated as

$$\begin{aligned}\mathbf{X}(k+1/k+1) &= E\{\mathbf{X}(k+1) | \mathbf{y}(1), \mathbf{y}(2), \dots, \mathbf{y}(k+1)\} \\ &= \mathbf{X}(k+1/k) + \mathbf{K}(k+1)[\mathbf{y}(k+1) - \mathbf{H}\mathbf{X}(k+1/k)]\end{aligned}\quad (3.3.6)$$

$$\mathbf{P}(k+1/k+1) = [\mathbf{I} - \mathbf{K}(k+1)\mathbf{H}]\mathbf{P}(k+1/k)[\mathbf{I} - \mathbf{K}(k+1)\mathbf{H}]^T + \mathbf{K}(k+1)\mathbf{V}_v\mathbf{K}(k+1)^T \quad (3.3.7)$$

where $\mathbf{K}(k+1)$ is the Kalman gain matrix which is defined as

$$\mathbf{K}(k+1) = \mathbf{P}(k+1/k)\mathbf{H}^T [\mathbf{H}\mathbf{P}(k+1/k)\mathbf{H}^T + \mathbf{V}_v]^{-1} \quad (3.3.8)$$

The extended Kalman filtering technique described above can be applied to the identification of system parameters as follows.

Consider a dynamic system described by a state equation as in Eq. 2.10,

$$\dot{\mathbf{x}} = \mathbf{f}(\mathbf{x}, \mathbf{u}, \boldsymbol{\theta}; t) + \mathbf{w}(t) \quad (3.3.9)$$

where \mathbf{x} is the state (response) of the system, \mathbf{u} is the input excitation and $\boldsymbol{\theta}$ denotes system parameters. Then, by defining a new augmented state vector as

$$\mathbf{X} = \begin{bmatrix} \mathbf{x} \\ \boldsymbol{\theta} \end{bmatrix} \quad (3.3.10)$$

a new nonlinear state equation can be constructed from Eq. 3.3.9 as

$$\dot{\mathbf{X}} = \begin{bmatrix} \mathbf{f}(\mathbf{x}, \boldsymbol{\theta}, \mathbf{u}; t) \\ \mathbf{0} \end{bmatrix} + \begin{bmatrix} \mathbf{w}(t) \\ \mathbf{0} \end{bmatrix} \quad (3.3.11)$$

The observation equation corresponding to Eq. 2.12 can be obtained as

$$\mathbf{y}(k) = [\mathbf{H}, \mathbf{0}] \begin{bmatrix} \mathbf{x}(k) \\ \boldsymbol{\theta}(k) \end{bmatrix} + \mathbf{v}(k) \quad (3.3.12)$$

By applying the extended Kalman filter to Eqs. 3.3.11 and 3.3.12, system parameter $\boldsymbol{\theta}$ can be estimated recursively as part of the state vector.

The estimates obtained by the extended Kalman filter method may be in general biased or divergent (Urain, 1980; Westerlund and Tyss, 1980). Some modified algorithms are proposed to improve the convergence property (Ljung, 1979; Song and Speyer, 1986; Hoshiya and Saito, 1984). In this study, the weighted global iteration procedure proposed in Hoshiya and Saito (1984) is used in example studies.

SECTION 4

NUMERICAL EXAMPLES AND DISCUSSION

In order to investigate the accuracy and efficiency of the various system identification techniques discussed in the preceding sections, example analyses have been carried out for four different cases: (i) an idealized suspension bridge model for wind loadings, (ii) a simplified model of an offshore structure for wave forces, (iii) a single-degree-of-freedom structure with bilinear hysteretic characteristics under seismic excitations, and (iv) an equivalent linear system for an offshore structure model. In each case, simulated data for input and output time histories are utilized for parameter identification purposes. The estimated system parameter values are compared with exact values which are assumed a priori. The responses simulated on exact parameter values and on estimated values are also compared. In the last example, the system identification method is applied to determination of the equivalent linear system of an offshore structure model.

4.1 Suspension Bridge Model (Shinozuka, Yun and Imai, 1982)

The idealized structural model shown in Fig. 2-2 is used. The equation of motion for wind loading is given in Eq. 2.5. Assumed values of the system parameters are shown in Table 4-I. Simulated time histories of the wind velocity fluctuations, $u(t)$ and $v(t)$, are shown in Fig. 4-1. The (simulated) observation time histories of the bridge motion, $Y_h(t)$ and $Y_\alpha(t)$ are shown in Figs. 4-2 and 4-3. The level of observational noise included in $Y_h(t)$ and $Y_\alpha(t)$ is assumed to be 10% of the structural response in the root mean square (RMS) value in both cases. For the purpose of system identification, the ARMAX model has been utilized in this example. Parameter estimation is carried out by using the least square (LS) method, instrumental variable (IV)

TABLE 4-I Exact and Estimated Parameters of Suspension Bridge

Parameters		$M^{-1}K$		$M^{-1}C$		$M^{-1}L$		σ_z
Exact Values		3.70	0.95	0.128	0.050	0.0020	-0.057	0.0309
		-0.12	18.25	-0.020	0.060	0.0003	0.012	0.0022
Estimates	LS	5.50	-0.75	3.194	-0.563	0.0037	-0.122	0.0160
		0.14	19.40	-0.013	0.606	0.0003	-0.013	0.0009
	IV	3.65	1.36	0.128	0.148	0.0015	-0.053	0.0300
		0.13	18.31	-0.020	0.058	0.0004	0.012	0.0023
	ML	3.72	-1.62	0.122	1.325	0.0019	-0.062	0.0327
		-0.11	18.19	-0.020	0.080	0.0011	0.012	0.0021

Note : 1. Observational noise is assumed as 10 % in RMS value

2. σ_z = standard deviation of z_1 and z_2

3. Unit : $[M^{-1}K] = 1/\text{sec}$; $[M^{-1}C] = 1/\text{sec}$;
 $[M^{-1}L] = 1/\text{sec}$ (first row), $1/\text{m}/\text{sec}$ (second row);
 $[\sigma_{z_1}] = \text{m}$ and $[\sigma_{z_2}] = \text{rad}/\text{sec}$.

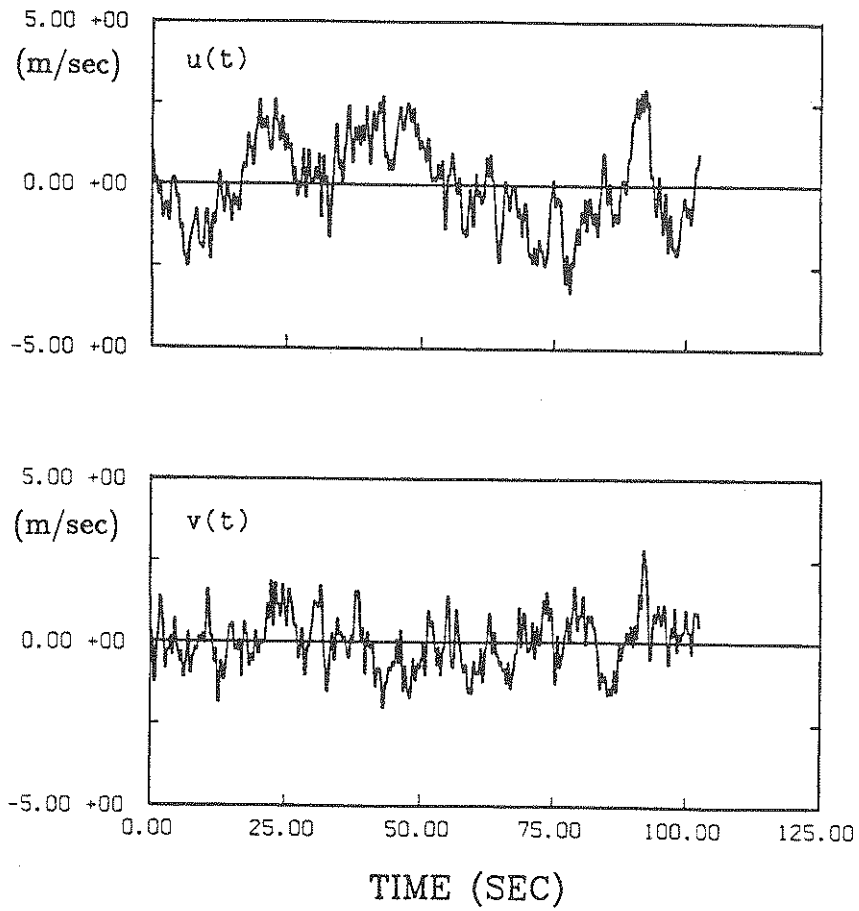

FIGURE 4-1 Simulated Time Histories of Wind Velocity Fluctuations
(Mean Horizontal Wind Speed = 10 m/sec)

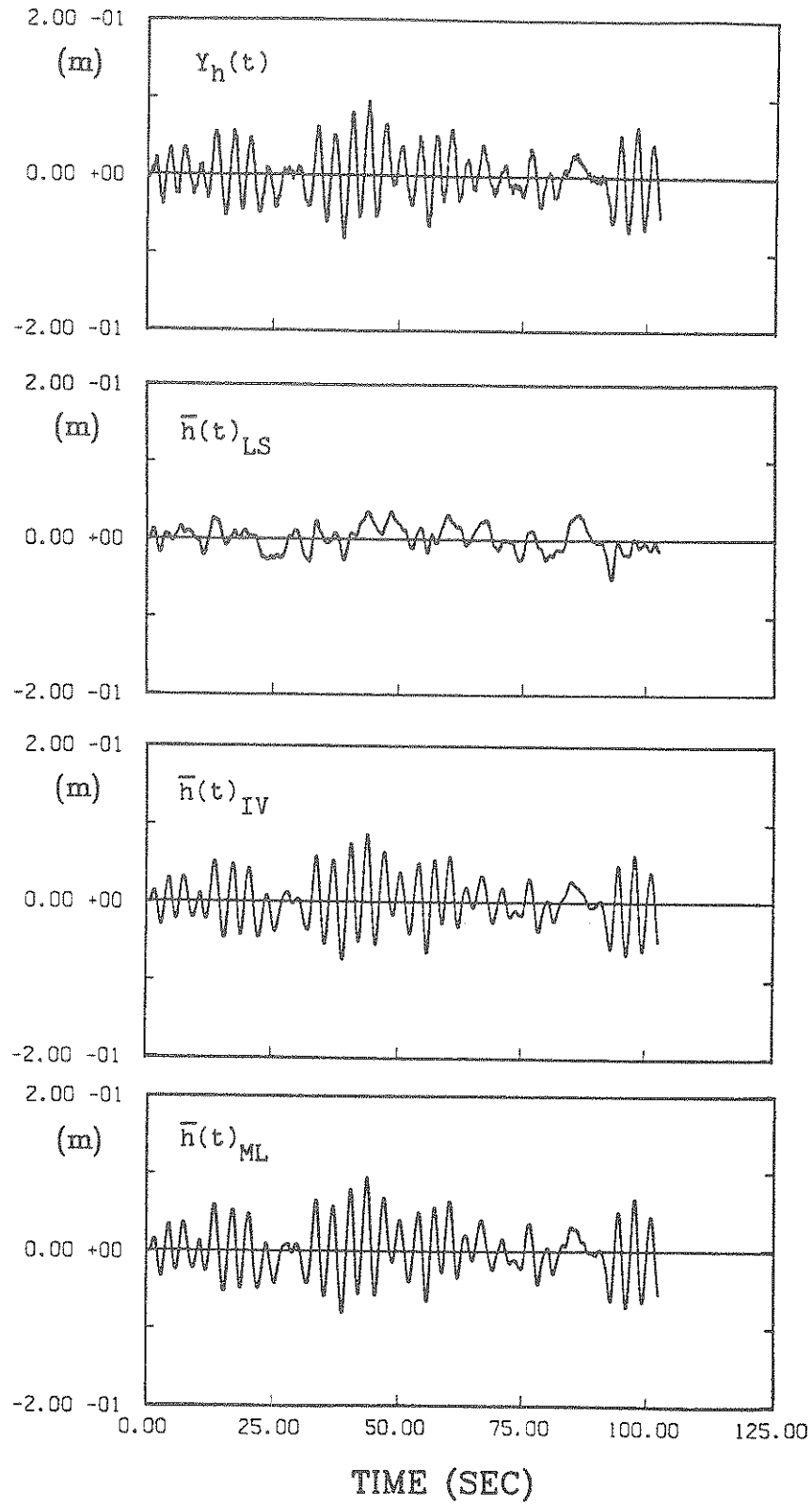

FIGURE 4-2 Time Histories of Observation $Y_h(t)$ and Estimated Responses $\bar{h}(t)$ for Heaving Motion of Suspension Bridge

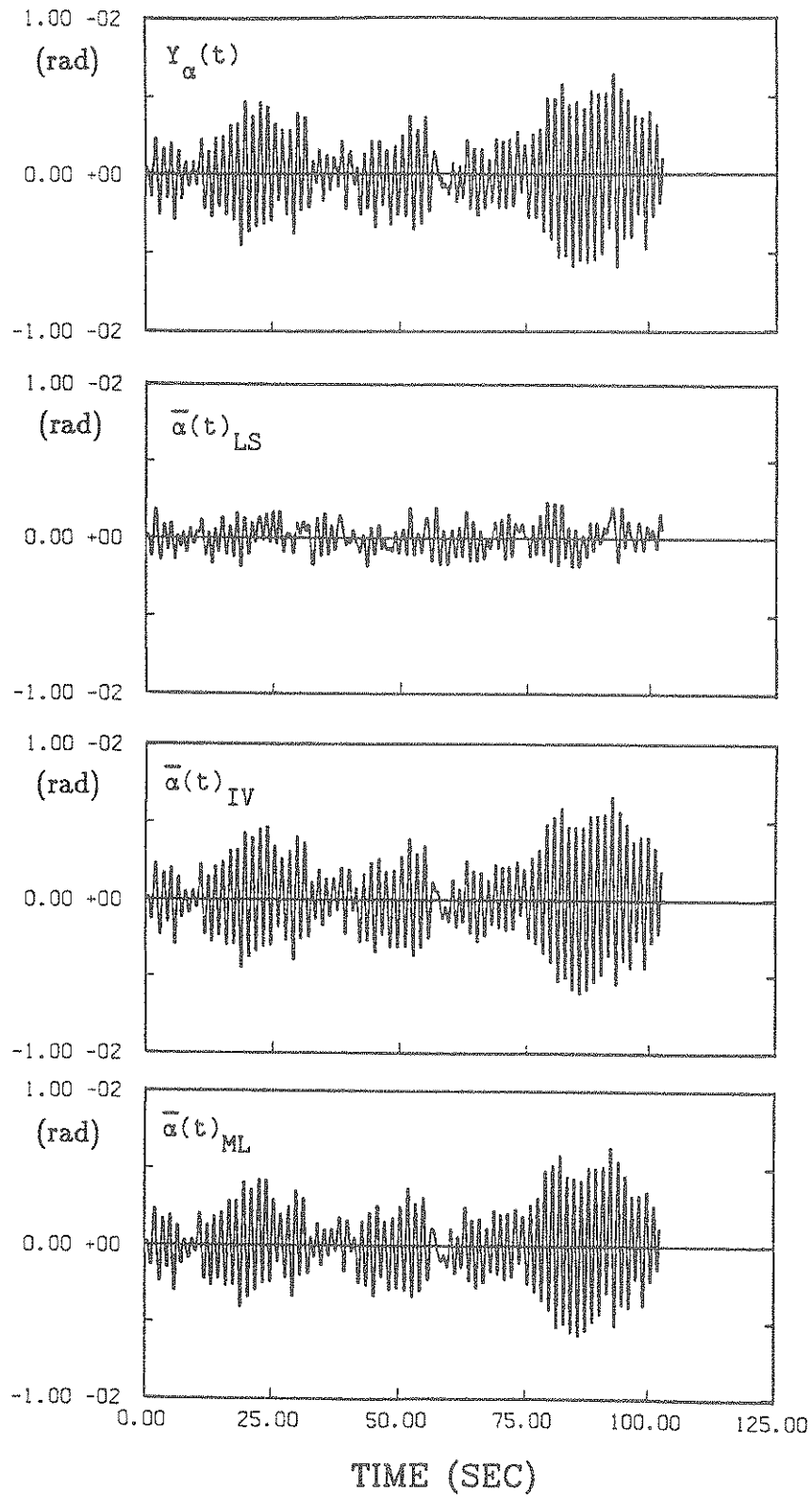

FIGURE 4-3 Time Histories of Observation $Y_{\alpha}(t)$ and Estimated Response $\bar{\alpha}(t)$ for Pitching Motion of Suspension Bridge

method and maximum likelihood (ML) method. The estimated parameter values are compared with (assumed) exact ones in Table 4-I. The response time histories $\bar{h}(t)$ and $\bar{\alpha}(t)$ recomputed using estimated parameters are also compared with those of the observation in Figs. 4-2 and 4-3. From the results in Table 4-I and Figs. 4-2 and 4-3, one can see that the IV and ML methods give good estimations of the parameters as well as structural responses. On the other hand, the results from the LS method are found to be unsatisfactory. The poor results of the LS estimates are due to the fact that the observational vector $\psi(i)$ in Eq. 3.1.5 is not statistically independent of the moving average noise term $\epsilon(i)$ in Eq. 3.1.1. Further numerical investigation indicates that the results from the ML method are less sensitive to observational noise than those from the IV method.

4.2 Offshore Structure (Yun and Shinozuka, 1980; Paliou and Shinozuka, 1988)

In this example, an offshore structure idealized as a two-degree-of-freedom system is utilized. The equation of motion for wave loading, Eq. 2.6, is simplified as

$$\ddot{\mathbf{z}} + \mathbf{J}\dot{\mathbf{z}} - \mathbf{D}\{(\dot{\mathbf{v}}-\dot{\mathbf{z}})|\dot{\mathbf{v}}-\dot{\mathbf{z}}|\} + \mathbf{Kz} = \mathbf{Lv} \quad (4.2.1)$$

where $\mathbf{J} = [\mathbf{M}_0 + \mathbf{C}_M]^{-1}\mathbf{C}$, $\mathbf{D} = [\mathbf{M}_0 + \mathbf{C}_M]^{-1}\mathbf{C}_D$, $\mathbf{K} = [\mathbf{M}_0 + \mathbf{C}_M]^{-1}\mathbf{K}_0$ and $\mathbf{L} = [\mathbf{M}_0 + \mathbf{C}_M]^{-1}\mathbf{C}_M$.

For system identification, Eq. 4.2.1 is transformed into a state-space model by using the augmented state vector defined as

$$\{\mathbf{X}\} = \{z_1 \quad z_2 \quad \dot{z}_1 \quad \dot{z}_2 \quad J_{11} \quad J_{21} \quad J_{12} \quad J_{22} \quad D_{11} \quad D_{22} \quad K_{11} \quad K_{21} \quad K_{12} \quad K_{22} \quad L_{11} \quad L_{22}\}^T \quad (4.2.2)$$

It is assumed that time histories of the displacement at the two discrete masses are available. Identification of the system parameters is carried out

by using the extended Kalman filtering with the weighted global iteration procedure (Hoshiya and Saito, 1984; Hoshiya and Maruyama, 1987).

Table 4-II shows the (assumed) exact and estimated values of the parameters for two sea states corresponding to two wind speeds of 25 and 75 ft/sec. Two different conditions of the observational noise (5 and 10% in the RMS values) are considered. The estimated values have been obtained through five global iterations. Figure 4-4 shows input time histories of wave particle velocities and accelerations. Figure 4-5 shows the exact response $z_1(t)$ and $z_2(t)$ obtained using the assumed (exact) parameters and simulated response observation, $Y_1(t)$ and $Y_2(t)$, as well as the estimated responses, $\bar{z}_1(t)$ and $\bar{z}_2(t)$, computed based on the identified parameters. Figure 4-6 demonstrates the convergence of recursive estimation of system parameters by the extended Kalman filtering algorithm.

The results in Tables 4-II and Fig. 4-5 indicate that the extended Kalman filtering technique yields fairly good estimates even under relatively severe nonlinear hydrodynamic loading conditions for both of the observational noise conditions. The initial estimates of the parameters were chosen to be quite far from the exact values. The error covariance matrix of the initial estimate has been taken fairly arbitrarily as a diagonal matrix with large values of the diagonal elements. However, it has been found that the estimated values converge to reasonable ones as the time step increases and as the iteration proceeds (Fig. 4-6). The estimated response obtained by using the identified parameters is found to be virtually identical to the exact response (Fig. 4-5).

4.3 Structure with Bilinear Hysteresis (Hoshiya and Maruyama, 1987)

A single-degree-of-freedom structure which exhibits bilinear hysteretic

TABLE 4-II Exact and Estimated Parameters of Offshore Structure Model

Wind Speed(ft/sec)				25		75	
				$\bar{\theta}$	$\bar{\theta}$	$\bar{\theta}$	$\bar{\theta}$
J ($\frac{1}{sec}$)	J ₁₁	0.187	0.4	0.225	0.261	0.166	0.150
	J ₂₁	-0.022	0.0	-0.008	0.028	-0.005	0.005
	J ₁₂	-0.111	0.0	-0.147	-0.168	-0.073	-0.043
	J ₂₂	0.150	0.4	0.127	0.103	0.132	0.125
D ($\frac{1}{ft}$)	D ₁₁	0.060	0.1	0.049	0.037	0.062	0.065
	D ₂₂	0.060	0.1	0.064	0.071	0.059	0.058
K ($\frac{1}{sec^2}$)	K ₁₁	3.750	5.0	3.743	3.717	3.779	3.794
	K ₂₁	-0.750	0.0	-0.721	-0.705	-0.753	-0.765
	K ₁₂	-3.750	0.0	-3.780	-3.779	-3.772	-3.765
	K ₂₂	2.500	4.0	2.465	2.449	2.503	2.520
L	L ₁₁	0.400	0.2	0.408	0.419	0.422	0.446
	L ₂₂	0.500	0.3	0.494	0.486	0.495	0.492
Observational Noise Level (% of response in R.M.S.)				5	10	5	10

Note : $\bar{\theta}_o$ = initial guesses of parameters θ ,
 $\bar{\theta}$ = Estimates by the Extended Kalman Filter after Fifth Global Iteration

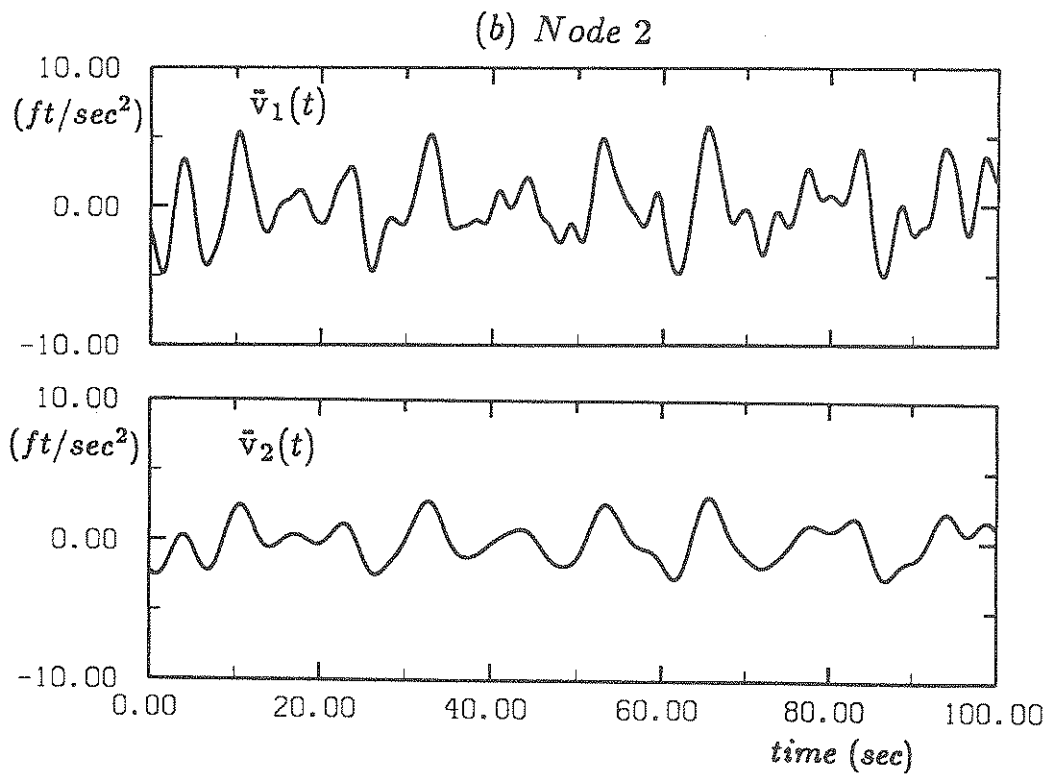
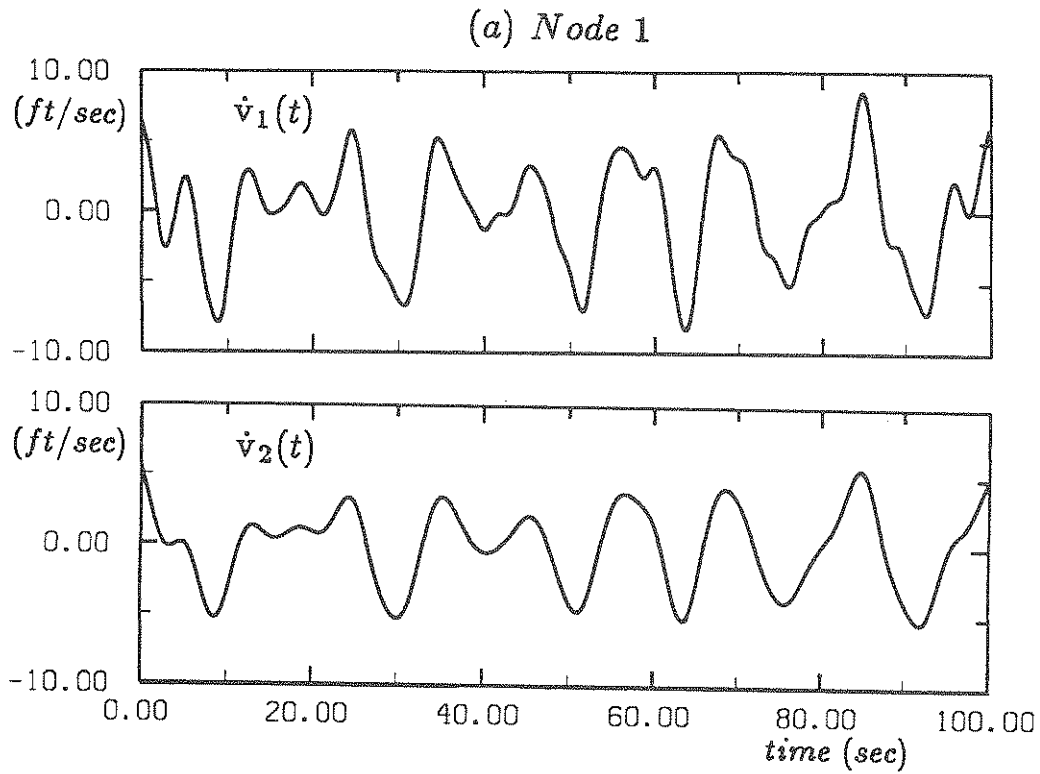

FIGURE 4-4 Simulated Time Histories of Wave Particle Velocities and Accelerations (Wind Speed = 75 ft/sec)

(a) Node 1

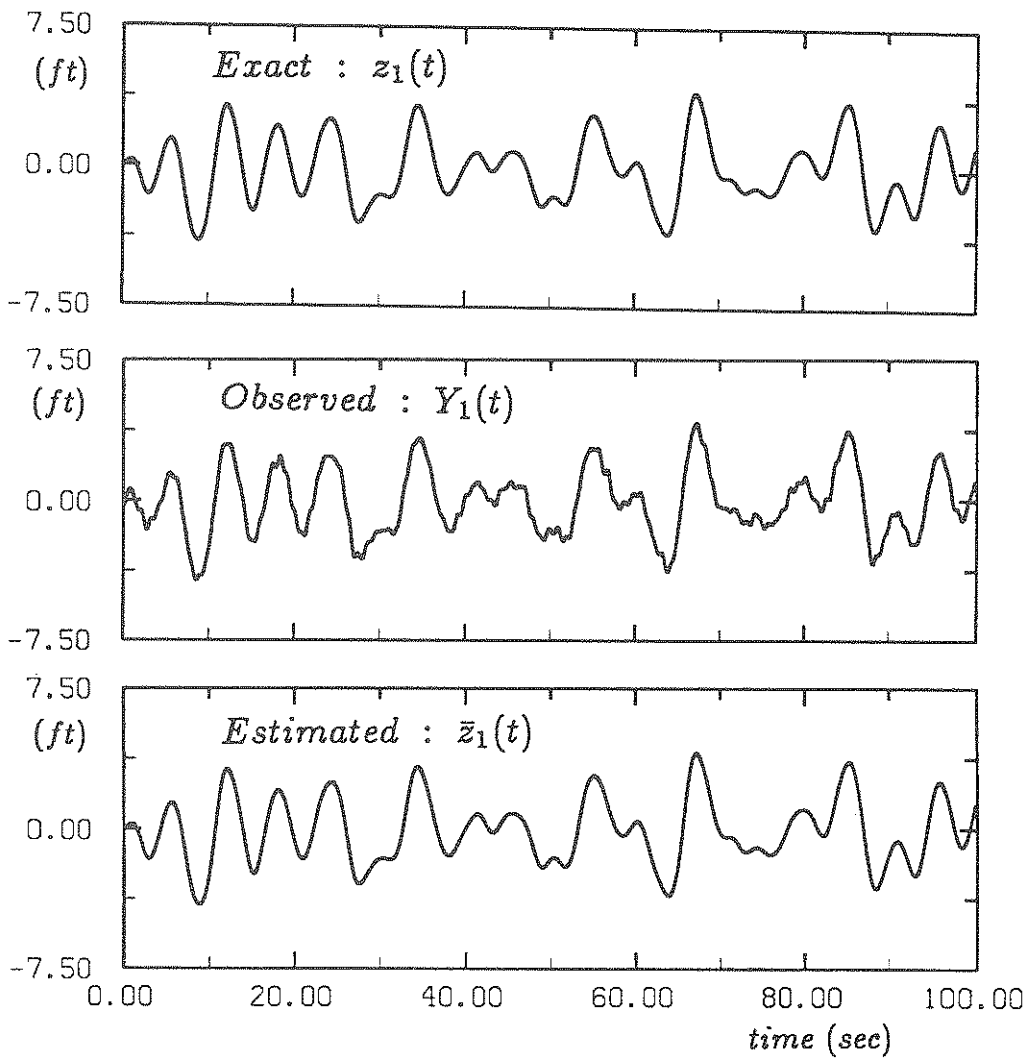

FIGURE 4-5-a Exact, Observed and Estimated Responses of Offshore Structure
(Wind Speed = 75 ft/sec; Noise Level = 10% of Response in RMS)

(b) Node 2

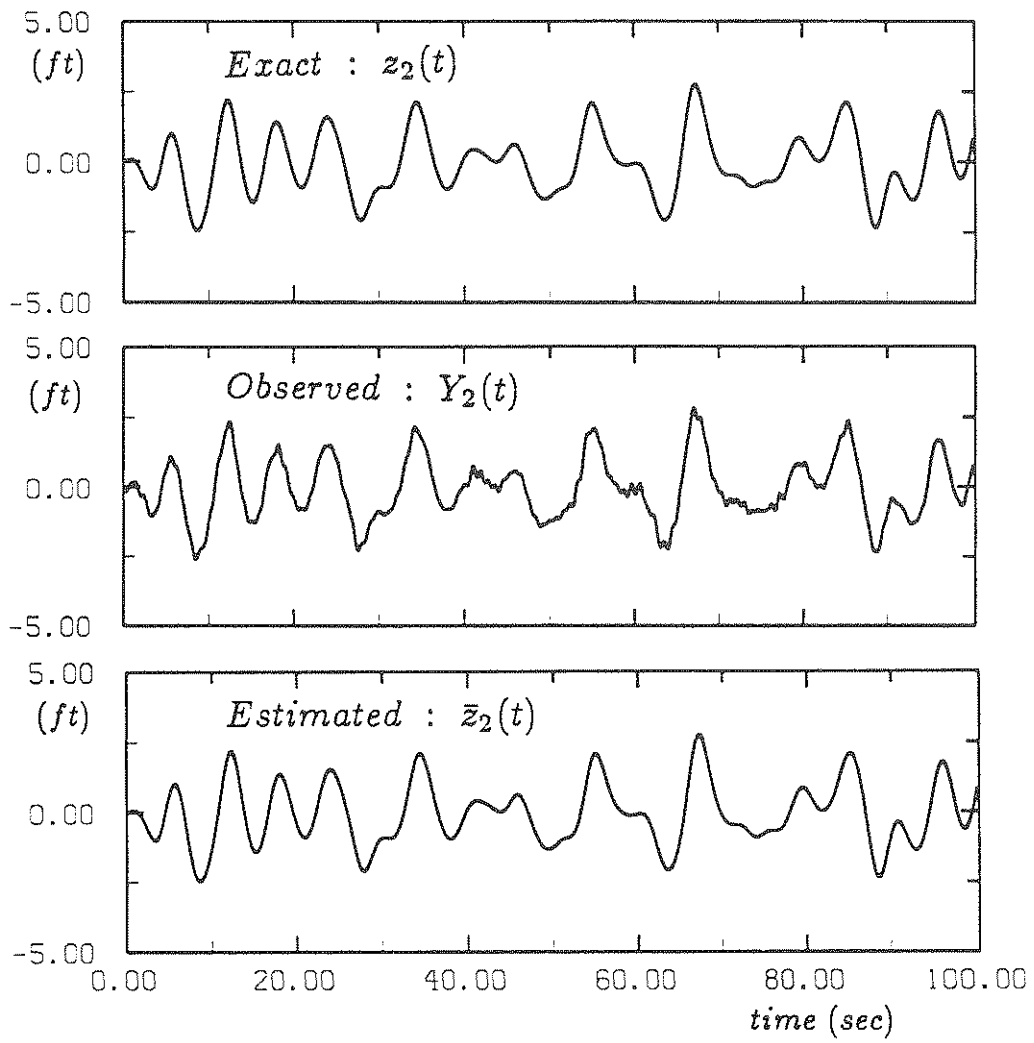
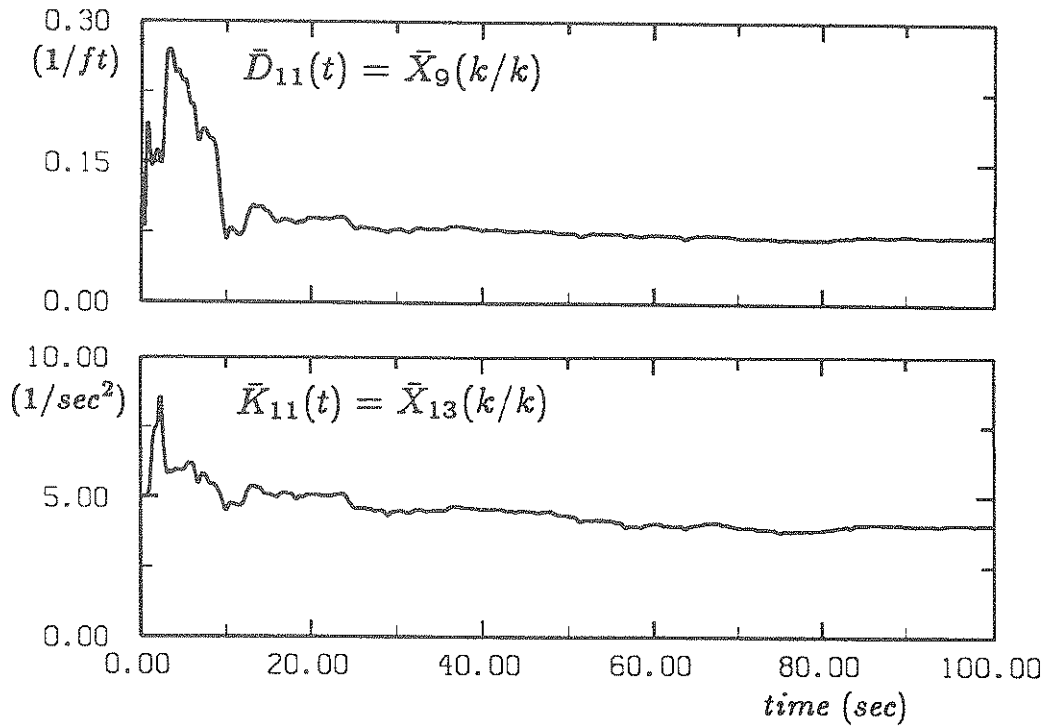

FIGURE 4-5-b Exact, Observed and Estimated Responses of Offshore Structure
(Wind Speed = 75 ft/sec; Noise Level = 10% of Response in RMS)

(a) First Iteration



(b) Fifth Iteration

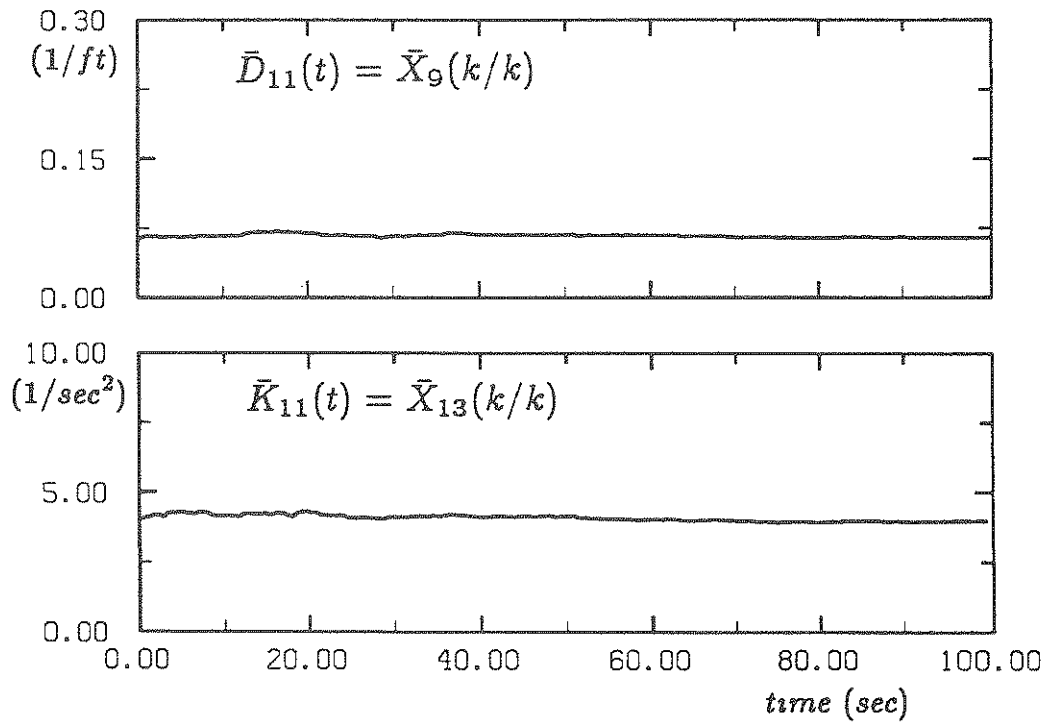

FIGURE 4-6 Estimated Parameters of Offshore Structure as Augmented State Variable (Wind Speed = 75 ft/sec; Noise Level = 10% of Response in RMS)

behavior under seismic excitation is identified. The equation of motion is written as

$$\ddot{z} + 2\xi\omega\dot{z} + \omega^2g(z_e, \alpha) = -\ddot{x}_g(t) \quad (4.3.1)$$

where ω and ξ are the natural frequency and damping ratio, respectively and $g(z_e, \alpha)$ defines the bilinear hysteresis with z_e being the yielding displacement and α being the ratio of post-yielding stiffness to pre-yielding stiffness as shown in Fig. 4-7.

For the purpose of system identification, Eq. 4.3.1 is rewritten into a nonlinear state equation by using the state vector defined as

$$\{X\} = \{z \quad \dot{z} \quad \xi \quad \omega \quad z_e \quad \alpha\}^T \quad (4.3.2)$$

Identification of parameters is carried out using the extended Kalman filtering technique with the weighted global iteration procedure.

As an input ground acceleration, the 1940 El Centro earthquake record (N-S component, Fig. 4-8) is utilized. It is assumed that time histories of the structural displacement and velocity are available (Figs. 4-9 and 4-10). The observational noise levels are taken as 10% of the structural response in the RMS values. Table 4-III shows the exact and estimated values of the system parameters. Figures 4-9 and 4-10 also show time histories of the estimated responses obtained after the fifth global iteration. Finally, Fig. 4-11 compares four different hysteretic characteristics. They are (a) true, (b) that obtained from observational data without the extended Kalman filtering procedure by

$$g(z_e, \alpha) = \frac{\{-\ddot{f}(t) - \ddot{z} - 2\xi\omega\dot{z}\}}{\omega^2} \quad (4.3.3)$$

and the remaining two, (c) and (d), obtained by using extended Kalman filter-

TABLE 4-III Exact and Estimated Parameters of Structure with Bilinear Hysteresis

Parameters	Exact Values	Initial Guesses	Estimates	
			First Iteration	Fifth Iteration
ξ	0.1	0.5	0.096	0.098
$\omega(rad/sec)$	3.14	1.0	3.157	3.147
$z_e(cm)$	3.0	1.0	2.979	3.025
α	0.1	0.5	0.090	0.088

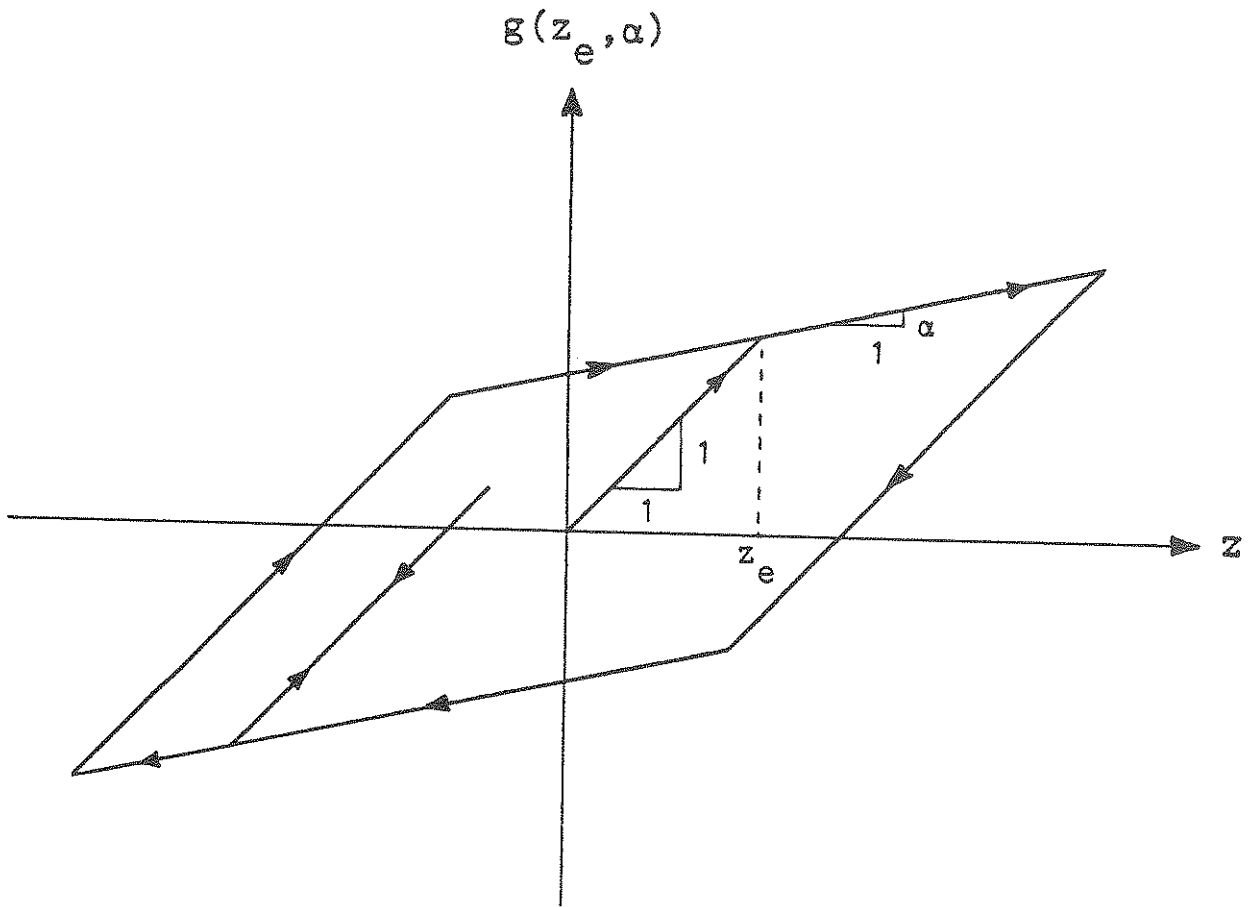

FIGURE 4-7 Bilinear Hysteresis

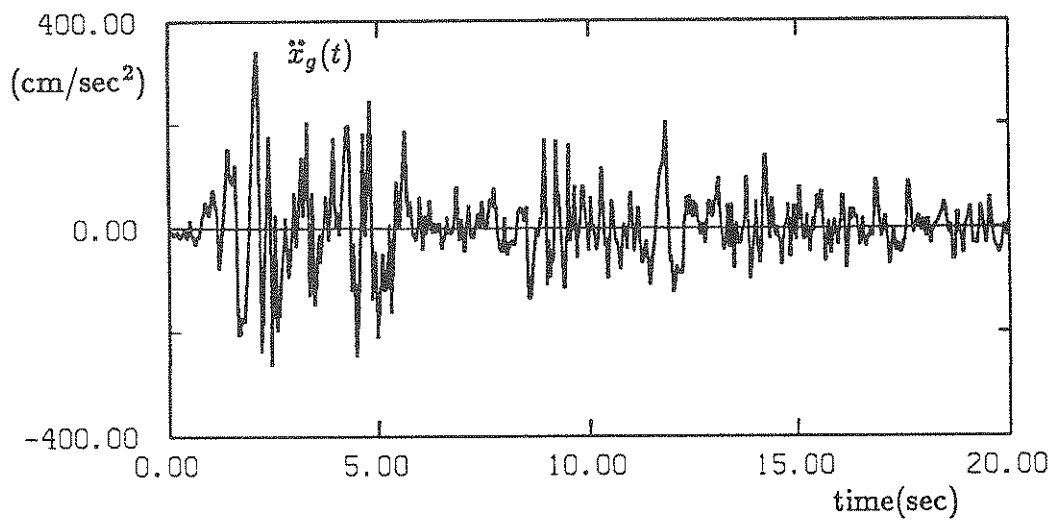

FIGURE 4-8 Input Ground Acceleration (1940 El Centro Earthquake, N-S Component)

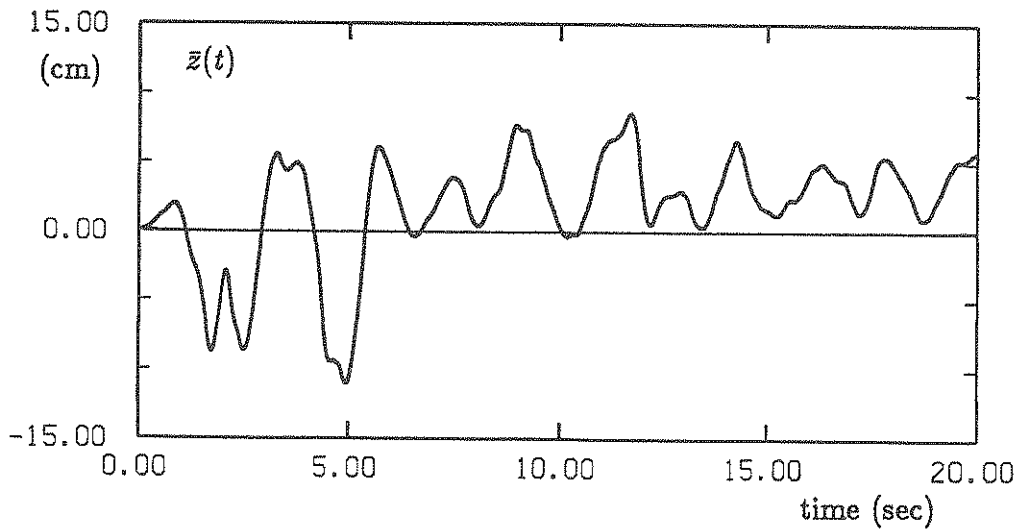
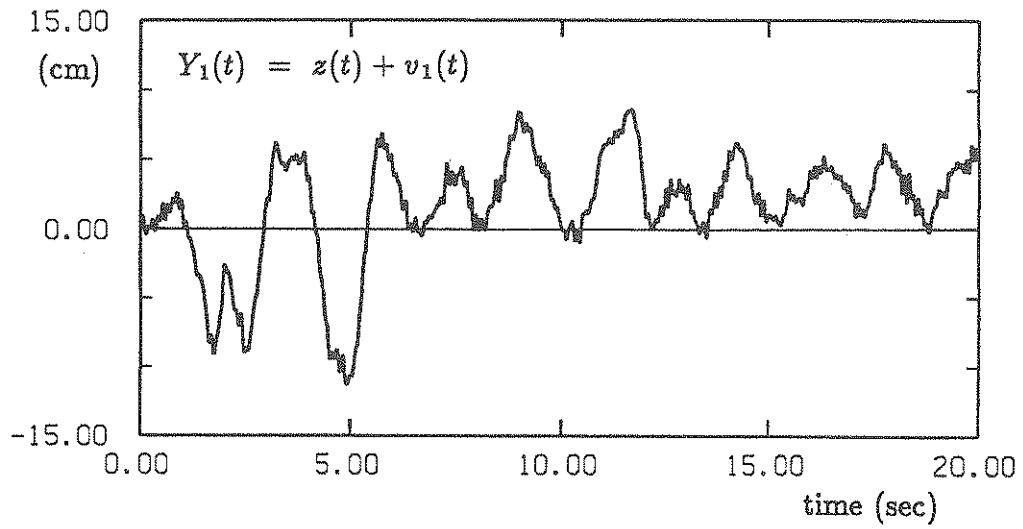

FIGURE 4-9 Observed and Estimated Displacement of Structure

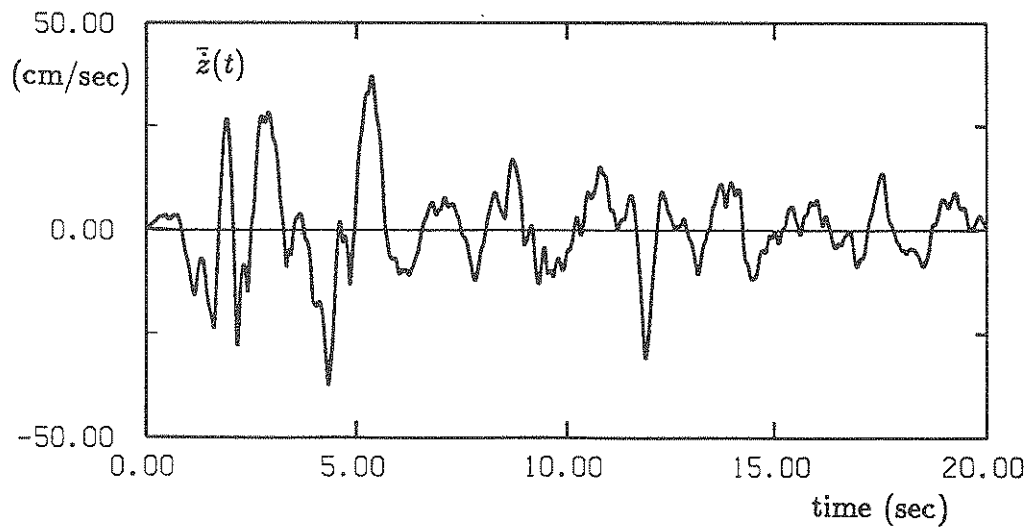
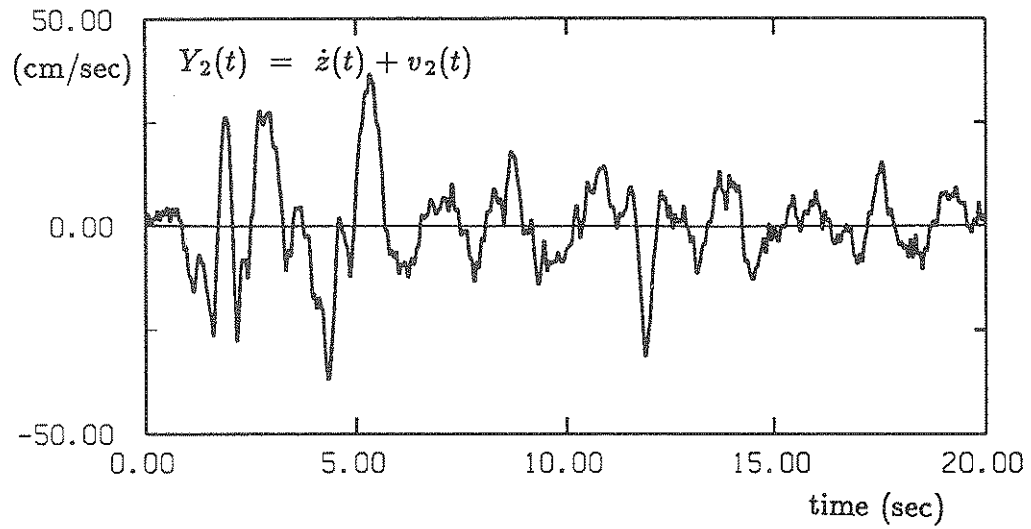
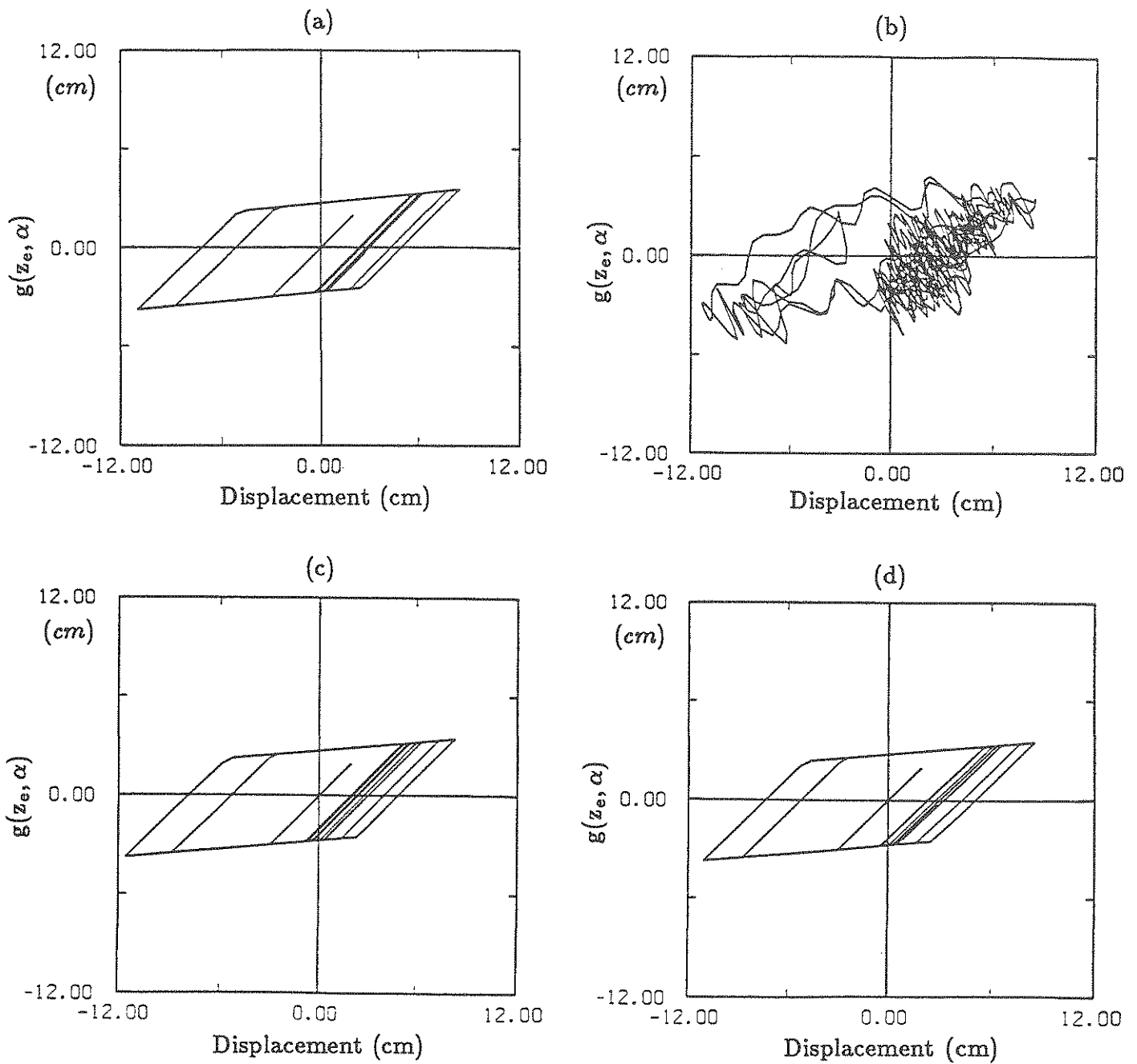

FIGURE 4-10 Observed and Estimated Velocity of Structure



(a) True Hysteresis (b) Estimated by Conventional Method
(c) Estimated by First Iteration (d) Estimated by Fifth Iteration

FIGURE 4-11 True and Estimated Hystereses

ing with weighted global iteration. The results in Table 4-III as well as Figs. 4-9, 4-10 and 4-11 indicate that extended Kalman filtering, particularly with the weighted global iteration procedure, estimates the system parameters and hysteretic behavior remarkably well even for the case of very severe material nonlinearity as shown in Fig. 4-11.

4.4 Identification of Equivalent Linear System (Paliou and Shinozuka, 1988)

In this example, equivalent linearization by means of a system identification technique is proposed. In general, the nonlinear characteristics of actual structures under severe environmental loading, such as earthquake, wind and waves are very difficult to model and analyze. Hence approximations in modeling are inevitable. For instance, in the case of offshore structures, the nonlinear hydrodynamic drag force is represented using drag coefficients which are determined semi-empirically based on representative values of the wave particle velocity and size, shape and surface roughness of the structural members. Because of the uncertainty and computational complexity associated with the nonlinear terms, the equivalent linearization technique has frequently been used in many analyses. The conventional method performs linearization by minimizing the error resulting from linearization and requires considerable numerical effort.

In the present example, the idealized offshore structure model used in Section 4.2 is utilized. From the nonlinear equation of motion, Eq. 4.2.1, a linearized equation is derived as

$$\ddot{\mathbf{z}} + \mathbf{J}^* \dot{\mathbf{z}} + \mathbf{K}^* \mathbf{z} = \mathbf{L}^* \ddot{\mathbf{v}} + \mathbf{D}^* (\dot{\mathbf{v}} - \dot{\mathbf{z}}) \quad (4.4.1)$$

where \mathbf{J}^* , \mathbf{K}^* , \mathbf{L}^* and \mathbf{D}^* are the parameters of the linearized system.

As in the previous example, time histories of the wave particle and ac-

celeration and structural displacement are assumed to be available at each node. The measurement noises are assumed to be 5% of the structural responses in the RMS values. The linearized parameters for the hydrodynamic drag force as well as for the other system parameters are identified by using the extended Kalman filtering technique with weighted global iteration. Two sea states corresponding to two wind speeds of 25 and 75 ft/sec are considered. Table 4-IV shows the assumed exact and estimated parameters. It should be noted here that the estimated values under each wind speed are the ensemble average of five sets of estimations arising from five sets of statistically identical but individually different wave particle motions, $\dot{\mathbf{v}}(t)$ and $\ddot{\mathbf{v}}(t)$, and observation time histories $\mathbf{Y}(t)$ generated by simulation. The estimated coefficient matrix \mathbf{D}^* has also been compared with the values computed by the conventional equivalent linearization procedure (Malhotra and Penzien, 1970). Figure 4-12 compares the observed response and estimated responses by two linearization methods. From the results in Fig. 4-12, it can be seen that the equivalent linear system obtained by using system identification can simulate the responses of the actual nonlinear system exceptionally well. The results in Table 4-IV indicate that for the case of small wave conditions where the nonlinear effect is not so significant, the linearized parameters obtained by the two linearization methods are somewhat different. However, as the wave condition becomes more severe and the nonlinear term becomes more important, the estimated values by two methods are found to be in good agreement. The above results indicate that the present method of equivalent linearization by means of system identification is considered to provide an efficient alternative to the conventional linearization method, particularly in view of the fact that all the coefficient matrices are assumed to be unknown in the present method, while only the linearized drag coefficient matrix

is considered unknown in the conventional method.

TABLE 4-IV Estimated Parameters of Equivalent Linear System

Parameters		Nonlinear System	Linear System		
			Initial Guesses	Estimated Value W=25 ft/sec	Estimated Value W=75ft/sec
J ($\frac{1}{sec}$)	J ₁₁	0.187	0.400	0.295	0.258
	J ₂₁	-0.022	0.000	-0.063	0.080
	J ₁₂	-0.111	0.000	-0.172	-0.299
	J ₂₂	0.150	0.400	0.249	0.097
K ($\frac{1}{sec^2}$)	K ₁₁	3.750	5.000	3.730	3.944
	K ₂₁	-0.750	0.000	-0.737	-0.744
	K ₁₂	-3.750	0.000	-3.766	-4.234
	K ₂₂	2.500	4.000	2.488	2.578
L	L ₁	0.400	0.200	0.405	0.353
	L ₂	0.500	0.300	0.506	0.597
D ($\frac{1}{ft}$)	D ₁₁	0.060	-	-	-
	D ₂₂	0.060	-	-	-
D* ($\frac{1}{sec}$)	D ₁ *	-	0.300	0.047(0.092)	0.357(0.441)
	D ₂ *	-	0.300	0.038(0.051)	0.289(0.330)

* The values in parenthesis were computed by the conventional linearization method assuming D₁* and D₂* are the only unknowns.

(a) Node 1

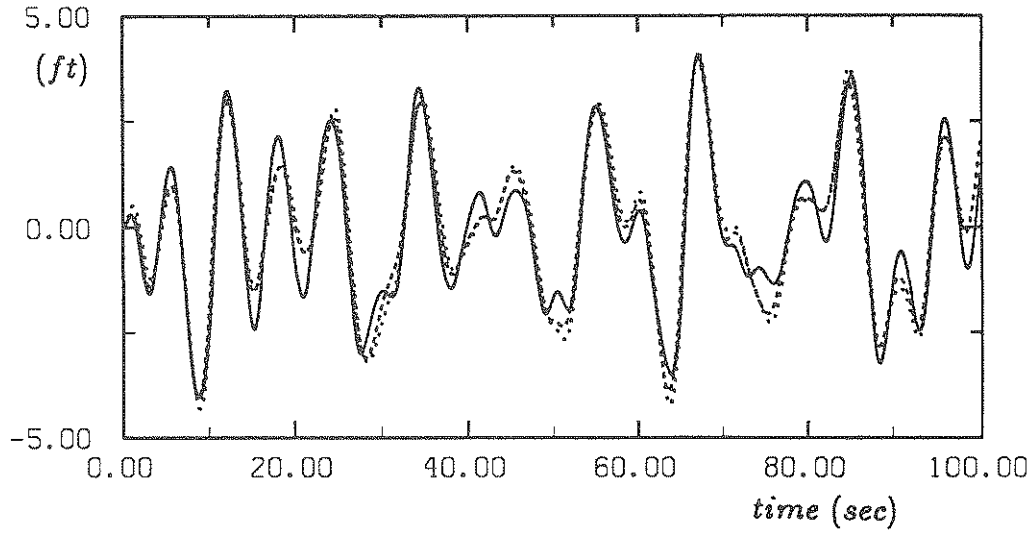

(b) Node 2

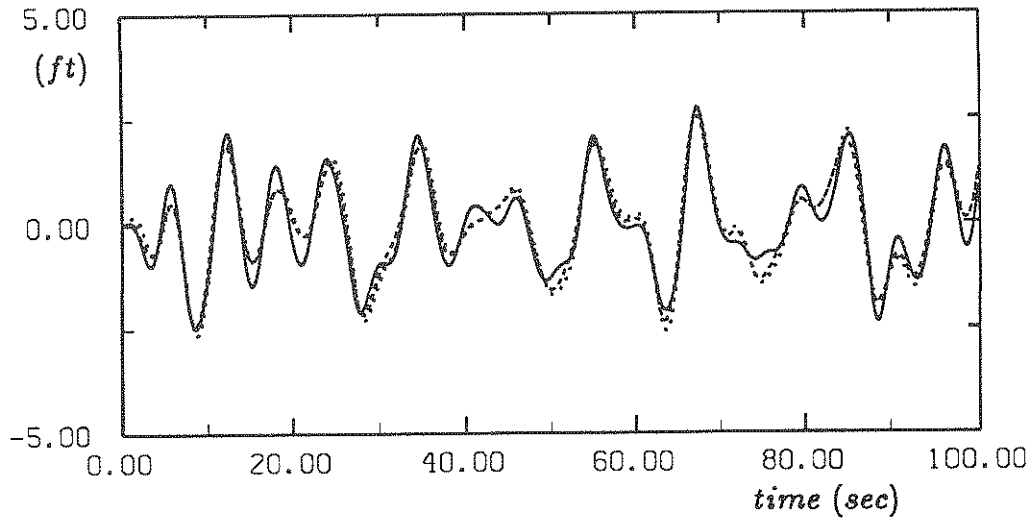

— = Exact
- - - = Estimated by Present Linearization
· · · = Estimated by Conventional Linearization

FIGURE 4-12 Exact and Estimated Displacement of Offshore Structure
(Wind Speed = 75 ft/sec; Noise Level = 5% of Response in RMS)

5. CONCLUSIONS

In this study, methods of parameter identification for structural dynamic systems are reviewed with emphasis on the identification of system parameters which vary with environmental loadings. For linear systems, the least squares, instrumental variable and maximum likelihood methods are reviewed. For nonlinear systems, a method utilizing the extended Kalman filter is discussed. Example numerical analyses are carried out for identification of the aerodynamic coefficients of a suspension bridge under wind loading, drag coefficients of an offshore structure under wind-induced wave forces, and yield displacement and stiffness ratio of a structure with bilinear hysteresis subjected to seismic excitation. From the numerical results, it has been found that the instrumental variable and maximum likelihood methods provide good estimates for a linear system, while the extended Kalman filtering technique with weighted global iteration yields excellent estimates for nonlinear cases. A method for developing an equivalent linear system by means of system identification is also presented and a numerical simulation study indicates that this method offers an efficient alternative to the conventional linearization method.

REFERENCES

1. Astrom, K.I. and Eykhoff, P. (1971). "System Identification - A Survey," Automatica, Vol. 7, pp. 123-162.
2. Chen, J-C. and Garba, J.A. (1987). "Structural Damage Assessment Using a System Identification Technique," Proceedings of the Workshop on Structural Safety Evaluation Based on System Identification Approaches, Lambrecht, West Germany, June 29-July 1, F. Vieweg & Sohn, Braunschweig, West Germany, pp. 474-492.
3. Dahlquist, G. and Björck, A. (1974). Numerical Methods, Prentice-Hall, Englewood Cliffs, New Jersey.
4. DiPasquale, E. and Cakmak, A.S. (1987). "Detection and Assessment of Seismic Structural Damage," NCEER Technical Report NCEER-87-0015, Dept. of Civil Engineering, Princeton University.
5. Eykhoff, P. (1974). System Identification - Parameter and State Estimation, John Wiley & Sons, New York.
6. Gertler, J. and Bányász, C. (1974). "A Recursive (On-Line) Maximum Likelihood Identification Method," IEEE Trans. on Automatic Control, Vol. AC-19, pp. 816-820.
7. Goodwin, G.C. and Payne, R.L. (1977). Dynamic System Identification: Experiment Design and Data Analysis, Academic Press, New York.
8. Hart, G.C. and Yao, J.T-P. (1977), "System Identification in Structural Dynamics," Journal of Engineering Mechanics, ASCE, Vol. 103, No. EM6, pp. 1089-1104.
9. Hoshiya, M. and Saito, E. (1984). "Structural Identification by Extended Kalman Filter," Journal of Engineering Mechanics, ASCE, Vol. 110, No. 12, pp. 1757-1770.
10. Hoshiya, M. and Maruyama, O. (1987). "Identification of Nonlinear Structural Systems," Proceedings of ICASP-5, Vancouver, Canada, Vol. I, pp. 182-189.
11. Proceedings of 6th IFAC Symposium on Identification and System Parameter Estimation, Arlington, Virginia, June 1982.
12. Kashyap, R.L. (1970). "Maximum Likelihood Identification of Stochastic Linear Systems," IEEE Trans. on Automatic Control, Vol. AC-15, pp. 25-34.
13. Kozin, F. and Natke, H.G. (1986). "System Identification Techniques," Structural Safety, Vol. 3, pp. 269-316.
14. Ljung, L. (1979). "Asymptotic Behavior of the Extended Kalman Filter as a Parameter Estimator for Linear Systems," IEEE Trans. Automatic Control, Vol. AC-24, pp. 36-50.

15. Ljung, L. (1987), System Identification - Theory for the User, Prentice-Hall, Englewood Cliffs, New Jersey.
16. Ljung, L. and Söderström, T. (1983). Theory and Practice of Recursive Identification, MIT Press, Cambridge, Massachusetts.
17. Malhotra, A. and Penzien, J. (1970). "Nondeterministic Analysis of Off-shore Structures," Journal of Engineering Mechanics, ASCE, Vol. 96, No. EM6, pp. 985-1003.
18. Natke, H.G., Yao, J.T-P. (1986). "System Identification Approach in Structural Damage Evaluation," ASCE Structures Congress '86, Preprint 17-1.
19. Paliou, C. and Shinozuka, M., "Identification of Equivalent Linear Systems," accepted for publication in the Journal of Engineering Mechanics, ASCE, 1988.
20. Shinozuka, M., Itagaki, H. and Hakuno, M. (1968). "Dynamic Safety Analysis of Multistory Buildings," Journal of Structural Engineering, ASCE, Vol. 94, No. ST1, pp. 309-330.
21. Shinozuka, M., Yun, C-B. and Imai, H. (1982). "Identification of Linear Structural Dynamic Systems," Journal of Structural Engineering, ASCE, Vol. 108, No. EM6, pp. 1371-1390.
22. Song, T.L. and Speyer, J.L. (1986). "The Modified Gain Extended Kalman Filter and Parameter Identification in Linear Systems," Automatica, Vol. 22, pp. 59-75.
23. Urain, B. (1980). "Asymptotic Convergence Properties of the Extended Kalman Filter Using Filtered State Estimates," IEEE Trans. on Automatic Control, Vol. AC-25, pp. 1207-1211.
24. Westerlund, T. and Tyss, T. (1980). "Remarks on Asymptotic Behavior of the Extended Kalman Filter as a Parameter Estimator for Linear Systems," IEEE Trans. Automatic Control, Vol. AC-25, pp. 1011-1012.
25. Wong, K.Y. and Polack, E. (1967). "Identification of Linear Discrete Time Systems Using the Instrumental Variable Method," IEEE Trans. on Automatic Control, Vol. AC-12, pp. 707-718.
26. Yun, C-B. and Shinozuka, M. (1980). "Identification of Nonlinear Structural Dynamic Systems," Journal of Structural Mechanics, Vol. 8., pp. 187-203.

**NATIONAL CENTER FOR EARTHQUAKE ENGINEERING RESEARCH
LIST OF PUBLISHED TECHNICAL REPORTS**

The National Center for Earthquake Engineering Research (NCEER) publishes technical reports on a variety of subjects related to earthquake engineering written by authors funded through NCEER. These reports are available from both NCEER's Publications Department and the National Technical Information Service (NTIS). Requests for reports should be directed to the Publications Department, National Center for Earthquake Engineering Research, State University of New York at Buffalo, Red Jacket Quadrangle, Buffalo, New York 14261. Reports can also be requested through NTIS, 5285 Port Royal Road, Springfield, Virginia 22161. NTIS accession numbers are shown in parenthesis, if available.

- NCEER-87-0001 "First-Year Program in Research, Education and Technology Transfer," 3/5/87, (PB88-134275/AS).
- NCEER-87-0002 "Experimental Evaluation of Instantaneous Optimal Algorithms for Structural Control," by R.C. Lin, T.T. Soong and A.M. Reinhorn, 4/20/87, (PB88-134341/AS).
- NCEER-87-0003 "Experimentation Using the Earthquake Simulation Facilities at University at Buffalo," by A.M. Reinhorn and R.L. Ketter, to be published.
- NCEER-87-0004 "The System Characteristics and Performance of a Shaking Table," by J.S. Hwang, K.C. Chang and G.C. Lee, 6/1/87, (PB88-134259/AS).
- NCEER-87-0005 "A Finite Element Formulation for Nonlinear Viscoplastic Material Using a Q Model," by O. Gyebi and G. Dasgupta, 11/2/87, (PB88-213764/AS).
- NCEER-87-0006 "Symbolic Manipulation Program (SMP) - Algebraic Codes for Two and Three Dimensional Finite Element Formulations," by X. Lee and G. Dasgupta, 11/9/87, (PB88-219522/AS).
- NCEER-87-0007 "Instantaneous Optimal Control Laws for Tall Buildings Under Seismic Excitations," by J.N. Yang, A. Akbarpour and P. Ghaemmaghami, 6/10/87, (PB88-134333/AS).
- NCEER-87-0008 "IDARC: Inelastic Damage Analysis of Reinforced Concrete Frame - Shear-Wall Structures," by Y.J. Park, A.M. Reinhorn and S.K. Kunnath, 7/20/87, (PB88-134325/AS).
- NCEER-87-0009 "Liquefaction Potential for New York State: A Preliminary Report on Sites in Manhattan and Buffalo," by M. Budhu, V. Vijayakumar, R.F. Giese and L. Baumgras, 8/31/87, (PB88-163704/AS). This report is available only through NTIS (see address given above).
- NCEER-87-0010 "Vertical and Torsional Vibration of Foundations in Inhomogeneous Media," by A.S. Veletsos and K.W. Dotson, 6/1/87, (PB88-134291/AS).
- NCEER-87-0011 "Seismic Probabilistic Risk Assessment and Seismic Margins Studies for Nuclear Power Plants," by Howard H.M. Hwang, 6/15/87, (PB88-134267/AS). This report is available only through NTIS (see address given above).
- NCEER-87-0012 "Parametric Studies of Frequency Response of Secondary Systems Under Ground-Acceleration Excitations," by Y. Yong and Y.K. Lin, 6/10/87, (PB88-134309/AS).
- NCEER-87-0013 "Frequency Response of Secondary Systems Under Seismic Excitation," by J.A. HoLung, J. Cai and Y.K. Lin, 7/31/87, (PB88-134317/AS).
- NCEER-87-0014 "Modelling Earthquake Ground Motions in Seismically Active Regions Using Parametric Time Series Methods," by G.W. Ellis and A.S. Cakmak, 8/25/87, (PB88-134283/AS).
- NCEER-87-0015 "Detection and Assessment of Seismic Structural Damage," by E. DiPasquale and A.S. Cakmak, 8/25/87, (PB88-163712/AS).
- NCEER-87-0016 "Pipeline Experiment at Parkfield, California," by J. Isenberg and E. Richardson, 9/15/87, (PB88-163720/AS).

- NCEER-87-0017 "Digital Simulation of Seismic Ground Motion," by M. Shinozuka, G. Deodatis and T. Harada, 8/31/87, (PB88-155197/AS). This report is available only through NTIS (see address given above).
- NCEER-87-0018 "Practical Considerations for Structural Control: System Uncertainty, System Time Delay and Truncation of Small Control Forces," J.N. Yang and A. Akbarpour, 8/10/87, (PB88-163738/AS).
- NCEER-87-0019 "Modal Analysis of Nonclassically Damped Structural Systems Using Canonical Transformation," by J.N. Yang, S. Sarkani and F.X. Long, 9/27/87, (PB88-187851/AS).
- NCEER-87-0020 "A Nonstationary Solution in Random Vibration Theory," by J.R. Red-Horse and P.D. Spanos, 11/3/87, (PB88-163746/AS).
- NCEER-87-0021 "Horizontal Impedances for Radially Inhomogeneous Viscoelastic Soil Layers," by A.S. Veletsos and K.W. Dotson, 10/15/87, (PB88-150859/AS).
- NCEER-87-0022 "Seismic Damage Assessment of Reinforced Concrete Members," by Y.S. Chung, C. Meyer and M. Shinozuka, 10/9/87, (PB88-150867/AS). This report is available only through NTIS (see address given above).
- NCEER-87-0023 "Active Structural Control in Civil Engineering," by T.T. Soong, 11/11/87, (PB88-187778/AS).
- NCEER-87-0024 "Vertical and Torsional Impedances for Radially Inhomogeneous Viscoelastic Soil Layers," by K.W. Dotson and A.S. Veletsos, 12/87, (PB88-187786/AS).
- NCEER-87-0025 "Proceedings from the Symposium on Seismic Hazards, Ground Motions, Soil-Liquefaction and Engineering Practice in Eastern North America," October 20-22, 1987, edited by K.H. Jacob, 12/87, (PB88-188115/AS).
- NCEER-87-0026 "Report on the Whittier-Narrows, California, Earthquake of October 1, 1987," by J. Pantelic and A. Reinhorn, 11/87, (PB88-187752/AS). This report is available only through NTIS (see address given above).
- NCEER-87-0027 "Design of a Modular Program for Transient Nonlinear Analysis of Large 3-D Building Structures," by S. Srivastav and J.F. Abel, 12/30/87, (PB88-187950/AS).
- NCEER-87-0028 "Second-Year Program in Research, Education and Technology Transfer," 3/8/88, (PB88-219480/AS).
- NCEER-88-0001 "Workshop on Seismic Computer Analysis and Design of Buildings With Interactive Graphics," by W. McGuire, J.F. Abel and C.H. Conley, 1/18/88, (PB88-187760/AS).
- NCEER-88-0002 "Optimal Control of Nonlinear Flexible Structures," by J.N. Yang, F.X. Long and D. Wong, 1/22/88, (PB88-213772/AS).
- NCEER-88-0003 "Substructuring Techniques in the Time Domain for Primary-Secondary Structural Systems," by G.D. Manolis and G. Juhn, 2/10/88, (PB88-213780/AS).
- NCEER-88-0004 "Iterative Seismic Analysis of Primary-Secondary Systems," by A. Singhal, L.D. Lutes and P.D. Spanos, 2/23/88, (PB88-213798/AS).
- NCEER-88-0005 "Stochastic Finite Element Expansion for Random Media," by P.D. Spanos and R. Ghanem, 3/14/88, (PB88-213806/AS).
- NCEER-88-0006 "Combining Structural Optimization and Structural Control," by F.Y. Cheng and C.P. Pantelides, 1/10/88, (PB88-213814/AS).
- NCEER-88-0007 "Seismic Performance Assessment of Code-Designed Structures," by H.H.-M. Hwang, J.-W. Jaw and H.-J. Chau, 3/20/88, (PB88-219423/AS).

- NCEER-88-0008 "Reliability Analysis of Code-Designed Structures Under Natural Hazards," by H.H-M. Hwang, H. Ushiba and M. Shinozuka, 2/29/88, (PB88-229471/AS).
- NCEER-88-0009 "Seismic Fragility Analysis of Shear Wall Structures," by J-W Jaw and H.H-M. Hwang, 4/30/88, (PB89-102867/AS).
- NCEER-88-0010 "Base Isolation of a Multi-Story Building Under a Harmonic Ground Motion - A Comparison of Performances of Various Systems," by F-G Fan, G. Ahmadi and I.G. Tadjbakhsh, 5/18/88, (PB89-122238/AS).
- NCEER-88-0011 "Seismic Floor Response Spectra for a Combined System by Green's Functions," by F.M. Lavelle, L.A. Bergman and P.D. Spanos, 5/1/88, (PB89-102875/AS).
- NCEER-88-0012 "A New Solution Technique for Randomly Excited Hysteretic Structures," by G.Q. Cai and Y.K. Lin, 5/16/88, (PB89-102883/AS).
- NCEER-88-0013 "A Study of Radiation Damping and Soil-Structure Interaction Effects in the Centrifuge," by K. Weissman, supervised by J.H. Prevost, 5/24/88, (PB89-144703/AS).
- NCEER-88-0014 "Parameter Identification and Implementation of a Kinematic Plasticity Model for Frictional Soils," by J.H. Prevost and D.V. Griffiths, to be published.
- NCEER-88-0015 "Two- and Three- Dimensional Dynamic Finite Element Analyses of the Long Valley Dam," by D.V. Griffiths and J.H. Prevost, 6/17/88, (PB89-144711/AS).
- NCEER-88-0016 "Damage Assessment of Reinforced Concrete Structures in Eastern United States," by A.M. Reinhorn, M.J. Seidel, S.K. Kunnath and Y.J. Park, 6/15/88, (PB89-122220/AS).
- NCEER-88-0017 "Dynamic Compliance of Vertically Loaded Strip Foundations in Multilayered Viscoelastic Soils," by S. Ahmad and A.S.M. Israil, 6/17/88, (PB89-102891/AS).
- NCEER-88-0018 "An Experimental Study of Seismic Structural Response With Added Viscoelastic Dampers," by R.C. Lin, Z. Liang, T.T. Soong and R.H. Zhang, 6/30/88, (PB89-122212/AS).
- NCEER-88-0019 "Experimental Investigation of Primary - Secondary System Interaction," by G.D. Manolis, G. Juhn and A.M. Reinhorn, 5/27/88, (PB89-122204/AS).
- NCEER-88-0020 "A Response Spectrum Approach For Analysis of Nonclassically Damped Structures," by J.N. Yang, S. Sarkani and F.X. Long, 4/22/88, (PB89-102909/AS).
- NCEER-88-0021 "Seismic Interaction of Structures and Soils: Stochastic Approach," by A.S. Veletsos and A.M. Prasad, 7/21/88, (PB89-122196/AS).
- NCEER-88-0022 "Identification of the Serviceability Limit State and Detection of Seismic Structural Damage," by E. DiPasquale and A.S. Cakmak, 6/15/88, (PB89-122188/AS).
- NCEER-88-0023 "Multi-Hazard Risk Analysis: Case of a Simple Offshore Structure," by B.K. Bhartia and E.H. Vanmarcke, 7/21/88, (PB89-145213/AS).
- NCEER-88-0024 "Automated Seismic Design of Reinforced Concrete Buildings," by Y.S. Chung, C. Meyer and M. Shinozuka, 7/5/88, (PB89-122170/AS).
- NCEER-88-0025 "Experimental Study of Active Control of MDOF Structures Under Seismic Excitations," by L.L. Chung, R.C. Lin, T.T. Soong and A.M. Reinhorn, 7/10/88, (PB89-122600/AS).
- NCEER-88-0026 "Earthquake Simulation Tests of a Low-Rise Metal Structure," by J.S. Hwang, K.C. Chang, G.C. Lee and R.L. Ketter, 8/1/88, (PB89-102917/AS).
- NCEER-88-0027 "Systems Study of Urban Response and Reconstruction Due to Catastrophic Earthquakes," by F. Kozin and H.K. Zhou, 9/22/88, to be published.

- NCEER-88-0028 "Seismic Fragility Analysis of Plane Frame Structures," by H.H-M. Hwang and Y.K. Low, 7/31/88, (PB89-131445/AS).
- NCEER-88-0029 "Response Analysis of Stochastic Structures," by A. Kardara, C. Bucher and M. Shinozuka, 9/22/88.
- NCEER-88-0030 "Nonnormal Accelerations Due to Yielding in a Primary Structure," by D.C.K. Chen and L.D. Lutes, 9/19/88, (PB89-131437/AS).
- NCEER-88-0031 "Design Approaches for Soil-Structure Interaction," by A.S. Veletsos, A.M. Prasad and Y. Tang, 12/30/88.
- NCEER-88-0032 "A Re-evaluation of Design Spectra for Seismic Damage Control," by C.J. Turkstra and A.G. Tallin, 11/7/88, (PB89-145221/AS).
- NCEER-88-0033 "The Behavior and Design of Noncontact Lap Splices Subjected to Repeated Inelastic Tensile Loading," by V.E. Sagan, P. Gergely and R.N. White, 12/8/88.
- NCEER-88-0034 "Seismic Response of Pile Foundations," by S.M. Mamoon, P.K. Banerjee and S. Ahmad, 11/1/88, (PB89-145239/AS).
- NCEER-88-0035 "Modeling of R/C Building Structures With Flexible Floor Diaphragms (IDARC2)," by A.M. Reinhorn, S.K. Kunnath and N. Panahshahi, 9/7/88.
- NCEER-88-0036 "Solution of the Dam-Reservoir Interaction Problem Using a Combination of FEM, BEM with Particular Integrals, Modal Analysis, and Substructuring," by C-S. Tsai, G.C. Lee and R.L. Ketter, 12/31/88.
- NCEER-88-0037 "Optimal Placement of Actuators for Structural Control," by F.Y. Cheng and C.P. Pantelides, 8/15/88.
- NCEER-88-0038 "Teflon Bearings in Aseismic Base Isolation: Experimental Studies and Mathematical Modeling," by A. Mokha, M.C. Constantinou and A.M. Reinhorn, 12/5/88.
- NCEER-88-0039 "Seismic Behavior of Flat Slab High-Rise Buildings in the New York City Area," by P. Weidlinger and M. Ettouney, 10/15/88, to be published.
- NCEER-88-0040 "Evaluation of the Earthquake Resistance of Existing Buildings in New York City," by P. Weidlinger and M. Ettouney, 10/15/88, to be published.
- NCEER-88-0041 "Small-Scale Modeling Techniques for Reinforced Concrete Structures Subjected to Seismic Loads," by W. Kim, A. El-Attar and R.N. White, 11/22/88.
- NCEER-88-0042 "Modeling Strong Ground Motion from Multiple Event Earthquakes," by G.W. Ellis and A.S. Cakmak, 10/15/88.
- NCEER-88-0043 "Nonstationary Models of Seismic Ground Acceleration," by M. Grigoriu, S.E. Ruiz and E. Rosenblueth, 7/15/88.
- NCEER-88-0044 "SARCF User's Guide: Seismic Analysis of Reinforced Concrete Frames," by Y.S. Chung, C. Meyer and M. Shinozuka, 11/9/88.
- NCEER-88-0045 "First Expert Panel Meeting on Disaster Research and Planning," edited by J. Pantelic and J. Stoyke, 9/15/88.
- NCEER-88-0046 "Preliminary Studies of the Effect of Degrading Infill Walls on the Nonlinear Seismic Response of Steel Frames," by C.Z. Chrysostomou, P. Gergely and J.F. Abel, 12/19/88.
- NCEER-88-0047 "Reinforced Concrete Frame Component Testing Facility - Design, Construction, Instrumentation and Operation," by S.P. Pessiki, C. Conley, T. Bond, P. Gergely and R.N. White, 12/16/88.

- NCEER-89-0001 "Effects of Protective Cushion and Soil Compliancy on the Response of Equipment Within a Seismically Excited Building," by J.A. HoLung, 2/16/89.
- NCEER-89-0002 "Statistical Evaluation of Response Modification Factors for Reinforced Concrete Structures," by H.H-M. Hwang and J-W. Jaw, 2/17/89.
- NCEER-89-0003 "Hysteretic Columns Under Random Excitation," by G-Q. Cai and Y.K. Lin, 1/9/89.
- NCEER-89-0004 "Experimental Study of 'Elephant Foot Bulge' Instability of Thin-Walled Metal Tanks," by Z-H. Jia and R.L. Ketter, 2/22/89, to be published.
- NCEER-89-0005 "Experiment on Performance of Buried Pipelines Across San Andreas Fault," by J. Isenberg, E. Richardson and T.D. O'Rourke, 3/10/89, to be published.
- NCEER-89-0006 "A Knowledge-Based Approach to Structural Design of Earthquake-Resistant Buildings," by M. Subramani, J.F. Abel, P. Gergely and C.H. Conley, 1/15/89, to be published.
- NCEER-89-0007 "Liquefaction Hazards and Their Effects on Buried Pipelines," by T.D. O'Rourke and P.A. Lane, 2/1/89, to be published.
- NCEER-89-0008 "Fundamentals of System Identification in Structural Dynamics," by H. Imai, C-B. Yun, O. Maruyama and M. Shinozuka, 1/26/89.

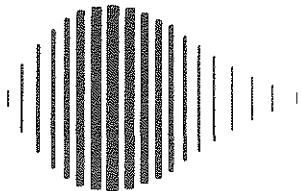
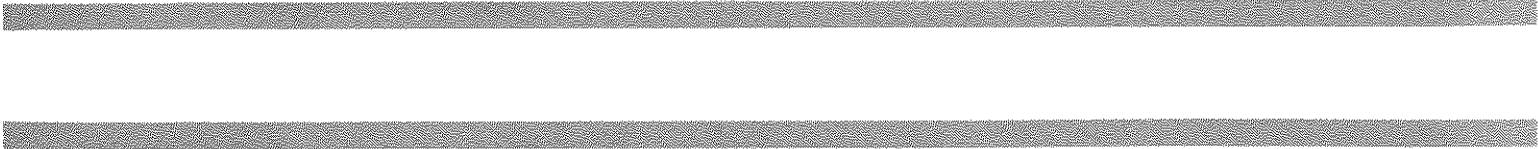

National Center for Earthquake Engineering Research
State University of New York at Buffalo