



*A National Center of Excellence in Advanced Technology Applications*

ISSN 1520-295X

---

# Urban Disaster Recovery: A Framework and Simulation Model

by

Scott B. Miles and Stephanie E. Chang

University of Washington  
Department of Geography  
Seattle, WA 98195-3550

Technical Report MCEER-03-0005

July 25, 2003

This research was conducted at the University of Washington and was supported primarily by the Earthquake Engineering Research Centers Program of the National Science Foundation under award number EEC-9701471.

## NOTICE

This report was prepared by the University of Washington as a result of research sponsored by the Multidisciplinary Center for Earthquake Engineering Research (MCEER) through a grant from the Earthquake Engineering Research Centers Program of the National Science Foundation under NSF award number EEC-9701471 and other sponsors. Neither MCEER, associates of MCEER, its sponsors, the University of Washington, nor any person acting on their behalf:

- a. makes any warranty, express or implied, with respect to the use of any information, apparatus, method, or process disclosed in this report or that such use may not infringe upon privately owned rights; or
- b. assumes any liabilities of whatsoever kind with respect to the use of, or the damage resulting from the use of, any information, apparatus, method, or process disclosed in this report.

Any opinions, findings, and conclusions or recommendations expressed in this publication are those of the author(s) and do not necessarily reflect the views of MCEER, the National Science Foundation, or other sponsors.



# Urban Disaster Recovery: A Framework and Simulation Model

by

Scott B. Miles<sup>1</sup> and Stephanie E. Chang<sup>2</sup>

Publication Date: July 25, 2003

Submittal Date: May 2, 2003

Technical Report MCEER-03-0005

Task Number 02-1031

NSF Master Contract Number EEC 9701471

- 1 Graduate Research Assistant, Department of Geography, University of Washington, Seattle
- 2 Research Assistant Professor, Department of Geography, University of Washington, Seattle

MULTIDISCIPLINARY CENTER FOR EARTHQUAKE ENGINEERING RESEARCH  
University at Buffalo, State University of New York  
Red Jacket Quadrangle, Buffalo, NY 14261

---



## Preface

The Multidisciplinary Center for Earthquake Engineering Research (MCEER) is a national center of excellence in advanced technology applications that is dedicated to the reduction of earthquake losses nationwide. Headquartered at the University at Buffalo, State University of New York, the Center was originally established by the National Science Foundation in 1986, as the National Center for Earthquake Engineering Research (NCEER).

Comprising a consortium of researchers from numerous disciplines and institutions throughout the United States, the Center's mission is to reduce earthquake losses through research and the application of advanced technologies that improve engineering, pre-earthquake planning and post-earthquake recovery strategies. Toward this end, the Center coordinates a nationwide program of multidisciplinary team research, education and outreach activities.

MCEER's research is conducted under the sponsorship of two major federal agencies: the National Science Foundation (NSF) and the Federal Highway Administration (FHWA), and the State of New York. Significant support is derived from the Federal Emergency Management Agency (FEMA), other state governments, academic institutions, foreign governments and private industry.

MCEER's NSF-sponsored research objectives are twofold: to increase resilience by developing seismic evaluation and rehabilitation strategies for the post-disaster facilities and systems (hospitals, electrical and water lifelines, and bridges and highways) that society expects to be operational following an earthquake; and to further enhance resilience by developing improved emergency management capabilities to ensure an effective response and recovery following the earthquake (see the figure below).

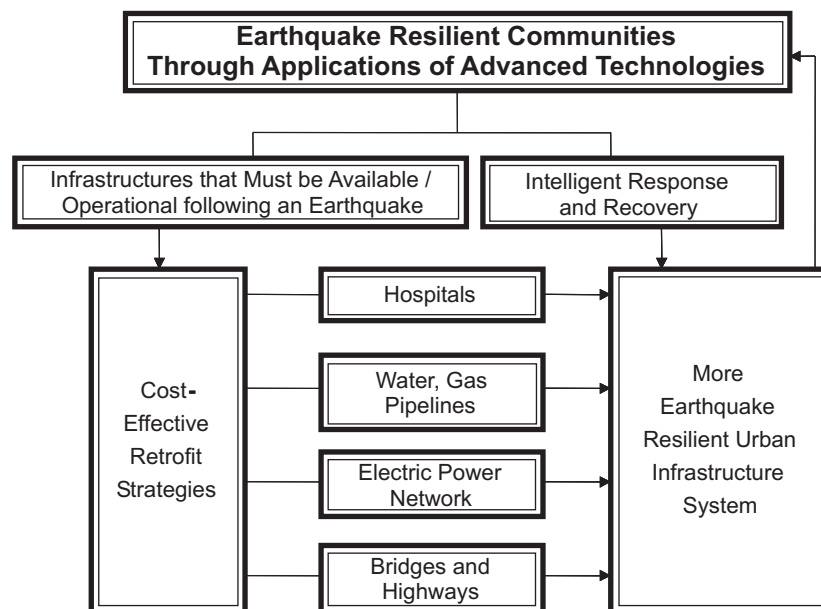

A cross-program activity focuses on the establishment of an effective experimental and analytical network to facilitate the exchange of information between researchers located in various institutions across the country. These are complemented by, and integrated with, other MCEER activities in education, outreach, technology transfer, and industry partnerships.

*The study described in this report focuses on developing an educational tool for illustrating concepts of community recovery, and identifying data collection and research needs for more refined recovery models in the future. A conceptual framework of disaster recovery, guided by insights from the empirical literature, is introduced. The resulting model focuses on simulating recovery processes, rather than on estimating dollar losses. It emphasizes the dynamic or temporal processes of recovery; simulates impacts at the individual agent level of analysis; relates recovery across business, household, and lifeline infrastructure sectors; relates recovery across individual, neighborhood, and community scales of analysis; highlights the key role of lifeline systems in recovery; and is designed to explore the complex consequences of mitigation, planning, and policy decisions. The model was applied to both a hypothetical community and to an area affected by a real earthquake, Kobe, Japan, and it was able to replicate broad trends from the disaster. The next step in this research is to formalize the insights obtained in the development and application of this model as recommendations for future research and development.*

## **Abstract**

This report concerns the modeling of urban recovery from earthquake disasters. In contrast to much of the earthquake loss estimation literature, we focus on simulating recovery processes rather than on estimating dollar losses. We first propose a conceptual framework of disaster recovery. This framework is guided by insights from the empirical literature. We then implement it in a prototype simulation model. The model is distinguished in several respects: (1) it emphasizes the dynamic or temporal processes of recovery; (2) it simulates impacts at the individual agent level of analysis; (3) it relates recovery across business, household, and lifeline infrastructure sectors; (4) it relates recovery across individual, neighborhood, and community scales of analysis; (5) it highlights the key role of lifeline systems in recovery; and (6) it is designed to explore the complex consequences of mitigation, planning, and policy decisions. We first test the prototype model by applying it to a hypothetical community. Results compare recovery timepaths in cases with and without pre-disaster mitigations. We then apply the prototype model to simulate an actual event, the 1995 Kobe earthquake, where we examine how well it replicates broad trends from the disaster. Further efforts are made to validate the model through sensitivity analysis. We conclude by identifying conceptual, methodological, and data issues that have emerged from this work.





# TABLE OF CONTENTS

SECTION	TITLE	PAGE
1	<b>Introduction</b> .....	1
2	<b>Literature Review</b> .....	3
	2.1 Modeling Disaster Loss .....	3
	2.2 Empirical Research on Recovery.....	5
	2.3 Urban Simulation.....	6
3	<b>Research Strategy</b> .....	9
	3.1 Modeling Philosophy.....	9
	3.2 Design and Prototype Phase Plan .....	10
	3.2.1 Stage 1: Conceptual design.....	10
	3.2.2 Stage 2: Proof of Concept.....	10
	3.2.3 Stage 3: Implementation .....	11
	3.2.4 Stage 4: Evaluation .....	11
	3.2.5 Stage 5: Synthesis .....	11
4	<b>Conceptual Model</b> .....	13
	4.1 Design Methodology .....	13
	4.2 Static Model.....	15
	4.3 Functional Model.....	18
5	<b>Simulation Implementation</b> .....	25
	5.1 Numerical Framework.....	25
	5.2 Simulation Equations.....	25
	5.2.1 Variable Definitions.....	26
	5.2.2 Business Functions .....	28
	5.2.3 Household Functions .....	29
	5.2.4 Community Functions.....	31
	5.2.5 Neighborhood and Lifeline Functions .....	32
	5.3 Computing Platform .....	34
6	<b>Test Application</b> .....	37
	6.1 Analysis Scenario .....	37
	6.2 Analysis Results.....	39
7	<b>Prototype Application: Base Model</b> .....	45
	7.1 Simulation Improvements.....	45
	7.2 Calibration of Model Parameters.....	47
	7.3 Kobe Scenario.....	51
	7.4 Results .....	54
8	<b>Prototype Application: Sensitivity Analysis</b> .....	63
	8.1 Sensitivity Analysis Approach .....	63

## TABLE OF CONTENTS (Cont'd)

SECTION	TITLE	PAGE
	8.2 Results .....	64
	8.2.1 Demographic Variables .....	65
	8.2.2 Decision Variables .....	66
<b>9</b>	<b>Synthesis and Conclusions</b> .....	<b>69</b>
	9.1 Emergent Issues and Recommendations.....	70
	9.1.1 Conceptual Limitations.....	70
	9.1.2 Simulation Algorithm Issues.....	72
	9.1.3 Challenges in Calibration.....	73
	9.1.4 Data Requirements.....	74
	9.1.5 Interpreting Simulation Output .....	75
	9.2 Further Research.....	76
	9.2.1 Stakeholder Evaluation of Prototype .....	76
	9.2.2 Improve Conceptual Model and Model Algorithms.....	76
	9.2.3 Integrate with GIS.....	77
	9.2.4 User Guide .....	78
<b>10</b>	<b>References</b> .....	<b>79</b>
<b>Appendix A</b>	<b>Narrative Basis of Model</b> .....	<b>83</b>

## LIST OF FIGURES

FIGURE	TITLE	PAGE
2-1	Schematic of disaster recovery .....	4
4-1	Main objects in conceptual model. The three parts of each box respectively indicate the object’s name, attributes, and behaviors or functions.....	17
4-2	Flow diagram for lifeline availability showing relationships of function inputs and outputs .....	19
4-3	Flow diagram for business recovery showing relationships of function inputs and outputs .....	20
4-4	Flow diagram for household recovery showing relationships of function inputs and outputs .....	21
4-5	Flow diagram for building damage severity showing relationships of function inputs and outputs.....	22
5-1	Screenshot of simulation implementation using Simulink .....	35
6-1	Household and business characteristics of neighborhoods in Simulated City .....	38
6-2	Average businesses recovery levels by neighborhood, “no mitigation” case.....	40
6-3	Average household recovery levels by neighborhood, “no mitigation” case.....	41
6-4	Average businesses recovery levels by neighborhood, lifeline mitigation case .....	43
6-5	Average household recovery levels by neighborhood, lifeline mitigation case .....	44
7-1	Kobe analysis zones.....	52
7-2	Overall simulated recovery of Kobe using simulation prototype .....	55
7-3	Simulated restoration of individual lifeline networks in Kobe using simulation prototype.....	56
7-4	Simulated recovery of households by zone for Kobe using simulation prototype .....	57
7-5	Simulated recovery of households by zone for relative recovery levels ...	58
7-6	Simulated recovery of businesses by zone for Kobe using simulation prototype .....	59
7-7	Simulated recovery of businesses by zone for relative recovery levels.....	60
7-8	Simulated restoration of buildings by zone for Kobe using simulation prototype .....	61



## LIST OF TABLES

<b>TABLE</b>	<b>TITLE</b>	<b>PAGE</b>
3-1	Stages in the recovery simulation research plan .....	10
5-1	Variable definitions for conceptual framework .....	27
6-1	Results of simulation, no lifeline mitigation scenario .....	42
7-1	Damage data used for calibrating recovery simulation .....	49
7-2	Calibrated values for driving variables .....	51
7-3	Decision variable values for Kobe application of model.....	51
7-4	Input household demographics for application to Kobe .....	53
7-5	Input business demographics for application to Kobe.....	53
7-6	Earthquake intensity values for Kobe recovery simulation .....	54
8-1	Expectations of simulation behavior for sensitivity analysis.....	64
8-2	Summary of sensitivity analysis of demographic variables for households .....	65
8-3	Summary of sensitivity analysis of demographic variables for businesses.....	65
8-4	Summary of sensitivity analysis of decision variables for households; pessimistic baseline.....	66
8-5	Summary of sensitivity analysis of decision variables for businesses; pessimistic baseline.....	67
8-6	Summary of sensitivity analysis of decision variables for households; Optimistic baseline.....	67
8-7	Summary of sensitivity analysis of decision variables for businesses; Optimistic baseline.....	67



# Section 1

## Introduction

Each disaster reminds us that, from an economic standpoint, losses do not occur instantaneously, but are accumulated over the course of a sometimes long and complex recovery process. Moreover, disasters are spatial events that impact some places and some groups within those places more heavily than others. These effects can be observed in both natural disasters and human-induced events. Thus in the September 11<sup>th</sup> tragedy of 2001, the loss of the World Trade Center towers and the thousands of human lives do not in themselves constitute the economic impact of the disaster. Neither does the loss of gross regional product (GRP) on the 11<sup>th</sup> itself. Rather, the economic impact of the disaster is strongly influenced by the multitude of decisions made in the days and months following – decisions regarding whether to relocate an office to New Jersey and for how long, whether to lay off workers and how many, and whether to inject stimulus spending into the New York City economy and how much. Similar post-event decisions strongly influence recovery in natural disasters such as floods or earthquakes. In other words, the process of disaster recovery is critical to understanding the spatial economic impacts of disasters, yet the recovery process itself is extremely complex and uncertain.

Perhaps as a result, no comprehensive framework or model of disaster recovery currently exists in the literature. Many studies touch upon facets of recovery, but none take it as their focus. A comprehensive model of recovery is needed in order to evaluate the potential consequences of decisions that affect disaster losses and recovery timepaths. This report describes completed work on the first stages of research towards a comprehensive recovery model and computer-based simulation. This work addresses the need for management and decision support tools for improving community resilience to disasters through exploration and analysis of strategies for reducing recovery time and any consequences related to failure of critical infrastructure. The recovery model and simulation also helps to further the social vulnerability perspective of disasters by operationalizing many of the observations and relationships identified within the

literature. Currently, the scope of the disaster recovery model and computer simulation is limited to earthquake disasters. However, most of the socio-economic concepts and relationships in the model are also applicable to other types of hazards.

Because disaster recovery is a very complex process, model development should be guided in part by empirical observations of actual disasters. Section 2 reviews the modeling literature on disaster economic losses, as well as the empirical literature on disaster recovery. It argues that current economic modeling has largely neglected issues of disaster recovery, and identifies numerous insights from the empirical literature that can help to address this research need. The literature on urban simulation and its applicability to disaster modeling is also discussed. Section 3 lays out the research strategy used in developing and evaluating the disaster recovery simulation. This includes conceptual design, proof of concept, implementation, evaluation, and synthesis. Section 4 develops a detailed and robust conceptual model for community disaster recovery by drawing from the literature review on loss and recovery modeling. The design methodology is based on Object Modeling Techniques (OMT). The conceptual model is translated into the computer simulation in Section 5 using a simple numerical framework. At this stage of development, in lieu of existing algorithms or formal theory, model algorithms are developed for prototyping and descriptive purposes only. Section 6 describes a test application of the prototype simulation to an earthquake striking a hypothetical city. Section 7 presents further development of the simulation and its use in modeling an actual disaster, the 1995 Kobe earthquake. This application is intended to test the broad performance of the prototype model and identify implementation issues, rather than to replicate the details of the disaster. Applying the recovery simulation to both a hypothetical and a real disaster provides insight into the feasibility of data collection, model calibration, and results interpretation. The behavior and sensitivity of the recovery simulation is explored in detail in Section 8. Sensitivity analysis is of particular importance because of the scarcity of data on socio-economic recovery on which to base statistical comparisons. Based on the three preceding sections, Section 9 concludes with recommendations for future versions of the disaster recovery model and a discussion of further research needs.



## Section 2

### Literature Review

#### **2.1 Modeling Disaster Loss**

A substantial literature has been emerging in recent years on modeling the economic impacts of natural disasters. Early studies proposed relatively simple applications of Input-Output methodologies (Cochrane, 1974; Kawashima and Kanoh, 1990), while recent research has developed increasingly sophisticated approaches including econometric models (West and Lenze, 1994), economic rebalancing models (Brookshire et al., 1997; Cochrane, forthcoming)<sup>1</sup>, sequential Input-Output models (Okuyama et al., 2000), computable general equilibrium models (Rose and Guha, 1999), and integrated infrastructure-economy models (Rose et al., 1997; Gordon et al., 1998; Cho et al., 2001; Chang et al., 2002). In all of these studies, impacts are primarily driven by damage to various economic sectors and inter-industry linkages. All of these studies focus on the urban or regional scale.

While the literature on loss modeling has been growing rapidly, modeling of recovery processes has been largely neglected. The significance of this distinction can be illustrated by the schematic diagram in Figure 2-1. Loss models generally focus on the initial loss caused by a disaster, treating the recovery timepath in a summary fashion; in the extreme case, losses are assumed to be incurred over one year, after which the economy returns to normal. Yet the recovery timepath itself clearly makes a great difference in determining loss, as illustrated by comparing the different disaster cases in the figure. Losses (from damage) and gains (from reconstruction stimulus) are measured as the difference between the disaster case and the without-disaster baseline. In Case A, the economy suffers a substantial initial loss followed by a small gain before returning to the baseline trend. By contrast, the economy in Case B eventually reaches a new equilibrium that is lower than the without-disaster baseline, indicating a much larger net

---

<sup>1</sup> HAZUS, the Federal Emergency Management Agency's nationally applicable earthquake loss estimation methodology, uses the economic rebalancing approach.

loss. In disaster Case C, the reconstruction stimulus pushes the economy to a new trend that is above the baseline, so that in the long run, gains may completely offset losses.

The extent to which the recovery timepath can be influenced by decision variables will be of great interest to policy-makers. To date, models incorporating temporal processes have focused on the temporal distribution of reconstruction spending, production chronology factors (Okuyama et al., 2000), reconstruction borrowing and debt repayments over time (Brookshire et al., 1997), and prioritizing lifeline reconstruction to minimize economic disruption (Rose et al., 1997; Cho et al., 2001).

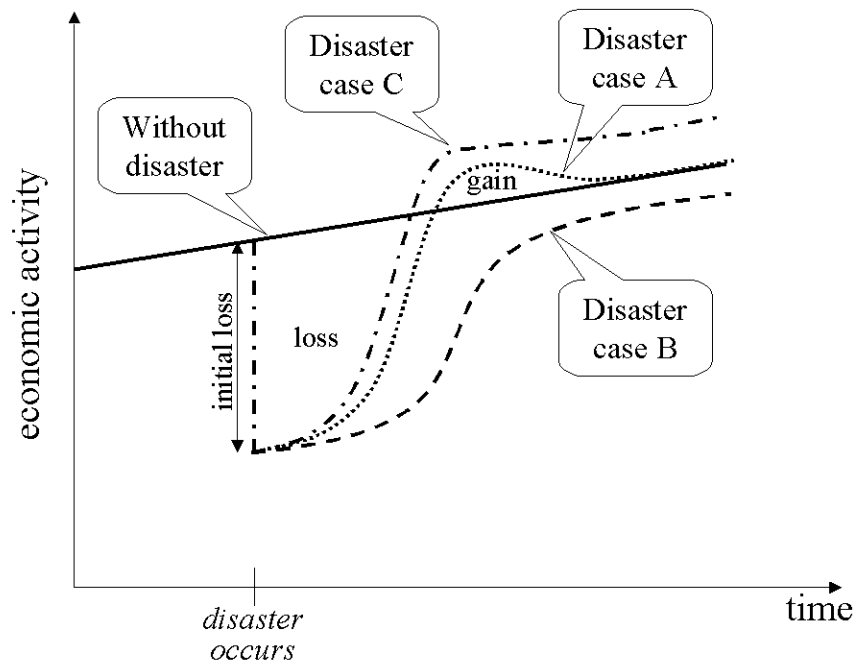

**Figure 2-1. Schematic of Disaster Recovery**

## **2.2 Empirical Research on Recovery**

In contrast, the empirical literature on disaster recovery as a process – while lacking any comprehensive models – provides many useful insights. The classical work by Haas, Kates and Bowden (1977) provides a generalized framework for disaster recovery in which a community undergoes four post-disaster stages in regular, predictable sequence. Subsequent case studies have cast doubt on this idea of an orderly, inevitable progression of recovery stages (Hogg, 1980; Rubin and Popkin, 1990; Rubin, 1991; Berke et al., 1993; Bolin, 1993). Instead, this more recent literature has been concerned with disparities and inequalities in recovery, and with conceptualizing disaster recovery as a social process involving decision-making, institutional capacity, and conflicts between interest groups. These themes resonate with development of social vulnerability theory in disaster studies, which suggest that marginal groups may not only be especially vulnerable to suffering losses, but they are likely to have more difficulty in recovering (Hewitt, 1997; Blaikie et al., 1994). They may, for example, have lesser access to insurance, loans, relief aid, or government bureaucracies and decision-making, or face shortages in low-income housing (e.g., Bolin and Bolton, 1986; Bolin and Stanford, 1991; Hirayama, 2000).

The importance of disparities has also been borne out by empirical studies of businesses in disasters. In various California earthquakes, researchers have found that small businesses and those that were generally marginal even before the disaster had the most difficulty in recovering (Durkin, 1984; Kroll et al., 1991; Tierney and Dahlhamer, 1998; Alesch and Holly, 1998). One study of the 1994 Northridge earthquake identified four main factors that significantly influenced the survival and recovery of small businesses: entrepreneurial skill of the business owner, post-event demand for the business' products, pre-event business characteristics such as financial condition, and availability of resources for recovery (Alesch and Holly, 1998).

Further, spatial effects have been found to be important in disaster recovery. Decentralization of population and economic activity may be accelerated (Chang, 2001), business losses are correlated with disaster severity in the neighborhood (Tierney and Dahlhamer, 1998), and retail and other locally-oriented businesses generally lag in recovery (Alesch and Holly, 1998; Kroll et al., 1991).

## **2.3 Urban Simulation**

Large-scale models that simulate urban change and development were first introduced in the 1950s and 1960s as methods and tools to support urban planning. The initial activity in this area faced numerous criticisms (Lee, 1973), including such issues as data-intensity, difficulties with calibration, weak theoretical basis, and their “black box” nature. Many but not all of these issues have been at least partly resolved in subsequent decades with more routine data collection by local governments, the advent of increasingly powerful computers, and efforts at better documentation (Wegener, 1994). For an overview of the developments in this area, see Klosterman (1994) and Waddell and Ulfarsson (forthcoming). For a recent bibliography, see Simpson (2001).

Urban simulation models have largely focused on two facets of urban development – land use and transportation. According to one review (Wegener, 1994), typical subsystems include residential location, employment location, residential and non-residential floorspace, land consumption, goods movement, travel patterns, and network congestion; however, most models treat only some of these. The models are generally applied to answer such questions as how land use or housing policies would affect development and transportation, or how transportation changes (e.g., a new highway) would affect the distribution of activities across the urban space (see, e.g., Landis and Zhang (1998) on the California Urban Futures Model). One class of models is structured around a unifying principle (e.g., minimizing transport costs) that allows for simultaneous solution across all the model elements. Another class is hierarchically structured, with subsystems that can be independently solved. The behavior of agents in many of the models (including households, firms, and travelers) is based on random utility or discrete choice theory. With a few exceptions, the models generally operate at a meso-scale, i.e., at the level of medium-sized zones or groups of households and industries.

The exceptions include microsimulation models that operate at the individual, household, and/or business level. Despite their data-intensive nature, microsimulation approaches have been increasing in popularity because behavioral theory is clearer at the individual level; moreover, such approaches allow a more detailed analysis of households from an equity perspective (Waddell and Ulfarsson, forthcoming). One particularly interesting case is UrbanSim, a microsimulation model intended to support planning

decisions regarding transportation, land use, and environment (Waddell, 2002). The model simulates the evolution of urban development over space and time. In it, the behavior of households, businesses, developers, and governments are interconnected through the urban land market. The model is based on random utility theory and employs methods of discrete-choice modeling for households and businesses. Inputs to the model include base year land use, population, employment, regional economic forecasts, transportation system plans, land use plans, and land development policies such as density and environmental constraints. For example, each household is stored in the database as an individual object with characteristics such as household size, number of workers, presence of children, age of household head, and income. The model predicts the creation or loss of households and jobs, intra-regional movement of households and jobs, the locational choices of households and jobs, land prices, and new construction. The model is run with annual timesteps. The user interacts with the model by defining scenarios, including indicating future population and employment growth expectations. The results of different scenarios can be compared using various output analysis tools. The model has been applied to several urban areas, including Eugene-Springfield, Oregon.

One review found few applications of simulation technologies to disaster planning and none to disaster recovery (Simpson, 2001). However, two more recent examples focus on transportation problems in earthquake disasters, one at the urban scale (Cho et al., 2001) and one at the regional scale (Kim et al., 2002). Because simulation models have largely been developed to model long-term urban development, they generally operate at time intervals of one to five years (Wegener, 1994). This is a major impediment to their applicability to analyzing disaster loss and recovery processes, for which time intervals of weeks or months are appropriate. Moreover, many of the models are based on equilibrium conditions for solution, which are questionable in the aftermath of disasters.



## Section 3

### Research Strategy

The remainder of the report describes the development of the disaster recovery conceptual model and computer simulation. The development focuses on earthquake-related disasters, but is largely applicable to other natural hazards such as hurricanes and flooding. The research strategy used to develop the simulation is described in more detailed below, with references to the corresponding sections of this report.

#### ***3.1 Modeling Philosophy***

Developing a conceptual model and simulation of disaster recovery should build on the major insights from the empirical literature (Section 2). This means challenging some of the conventions of regional economic modeling: emphasizing dynamic processes over static equilibrium models, recognizing differences between individual agents within a sector, addressing spatial feedback effects, and acknowledging model limitations by allowing for randomness and uncertainty.

Computer simulations should facilitate “what if” analyses by comparing different scenarios. Specifically, it is important to be able to characterize the influence of different decision options for reducing risk and thus reducing recovery times and related costs. These decision options include structural mitigation, such as retrofitting lifelines, and vulnerability reduction, such as mutual aid agreements and poverty alleviation. A simulation approach is appealing because these sorts of complex variables can be dealt with in a flexible manner, whereas purely theoretical or empirical models induce constraints regarding what types of variables (data) and knowledge can be used. An agent-based or bottom-up approach to simulation is adopted here, where, for this application, agents refer to important economic actors within the modeled system. At this point, the important agents are taken to be households and businesses. The simulation is then built up by characterizing the attributes and behaviors of the agents and describing relationships between agents themselves and relationships with their environment, such as buildings of residence and transportation networks. Complex and

interesting simulations then arise out of computing the interactions between these simply specified agents. This bottom-up approach is well suited to the vulnerability component of risk assessment because it allows asking questions related to, for example, a populations’ diversity of incomes and the vulnerability of their respective residences.

### **3.2 Design and Prototype Phase Plan**

The design and prototype phase of the research has been completed, with the exception of stakeholder (i.e., intended users such as emergency managers) evaluation of the prototype simulation and is reported here. This initial phase was conducted in five overlapping stages listed in Table 3-1. The objectives of each stage are described below and are related to the respective sections within the report. While the research plan is presented as a sequence, there was considerable feedback and iteration between steps.

**Table 3-1. Stages in the recovery simulation research plan**

Stage 1.	Conceptual Design
Stage 2.	Proof of Concept
Stage 3.	Implementation
Stage 4.	Evaluation
Stage 5.	Synthesis

#### **3.2.1 Stage 1: Conceptual Design**

The objective of the conceptual design stage is to create a sound, flexible foundation for implementing and understanding the simulation (or multiple simulation implementations), promoting understanding of disaster recovery, and motivating much-needed data collection and empirical research. The results of conceptual design are described in Section 4.

#### **3.2.2 Stage 2: Proof of Concept**

The objectives of the proof of concept step are to assess the feasibility of the computer simulation and evaluate potential computing platforms. The feasibility was initially assessed by quantifying the conceptual model with spreadsheet software for a very simple case (one household and one business). This demonstrated that, while



complex, the simulation and its many variables and relationships could be encoded using the appropriate tools. It was determined, however, that spreadsheet software is not appropriate because of the difficulty in specifying and debugging simulation functions, especially for large simulations. Further lessons learned regarding computing platform requirements are described in Section 5.3. After addressing these needs and initial simulation implementation, further feasibility assessment was performed, as described in Section 6.

### **3.2.3 Stage 3: Implementation**

The objectives of implementation are to operationalize the conceptual design as computer algorithms and determine how to express these algorithms within the chosen computing platform. It was also important to match the flexibility inherent in the conceptual design so that the simulation algorithms and programming can be conveniently modified, ported (to other computing environments) and updated. Sections describing the aspects of implementation are Sections 5 and 6.

### **3.2.4 Stage 4: Evaluation**

The objectives of evaluation, described in Sections 7 through 8, include assessing the performance of the simulation algorithms and output. This stage also includes evaluating the relative ease in applying the simulation to real-world problems. Further evaluation, currently not completed, will engage potential stakeholders of the recovery simulation. This will assist in further specifying the requirements of the simulation, such as user interface requirements, relevant decision variables, and delivery format, in order to meet the overall goal of a spatial decision support system for disaster recovery.

### **3.2.5 Stage 5: Synthesis**

The last stage of this research phase is presented in Section 9. The objective of synthesis is to cull together the insights gained from completed research towards designing the next phase of work. The next phase in the simulation development will work on developing more representative and robust algorithms, in addition to migrating towards the final objective of a GIS-based decision support system.



## **Section 4**

### **Conceptual Model**

In order to translate findings from the empirical literature into a simulation of the urban disaster recovery process, a conceptual model is needed. The conceptual model of disaster recovery is derived more by induction than by deduction – it is, in other words, guided by empirical observations rather than distilled from rigorous theory. It pays particular attention to how differences between business types and between household types help to determine recovery prospects. Thus, while the recovery simulation is intended to *measure* recovery at the community and neighborhood levels, it *models* recovery at the scale of the individual business and household. Moreover, the simulation models the influence of agents' environments on their recovery processes.

The conceptual model reflects numerous simplifications. These may be addressed at later stages of development. For instance, it allows agents to exit the region – businesses can fail and households can leave – but it does not capture how they might relocate within the region following the disaster. Also, while it distinguishes between locally-oriented and export-oriented production sectors, a distinction shown to be important in the empirical literature, it does not disaggregate these into specific industries. In terms of community-level and policy variables, the framework emphasizes the role of lifeline infrastructure restoration.

#### **4.1 Design Methodology**

The methodology adopted for designing the recovery model is based on the Object Modeling Technique (OMT) introduced in Rumbaugh et al. (1991). OMT is a methodology for conceptual modeling, originally used in software engineering. With OMT, the conceptual model is comprised of (1) the object (or static) model, (2) the dynamic model, and (3) the functional model, which together describe the real world system, and comprise an implementation-independent design.

There are several reasons why OMT is appealing as a means of designing the disaster recovery simulation model. Perhaps most obvious is the paucity of numerical data that can be used in developing a simulation of such high detail and broad scope. Similarly, as described above, there is a rich body of knowledge (including various theories and conceptual models, qualitative data, and quantitative data) on which to base a model. OMT provides an effective way of incorporating this available knowledge and is not hampered by the lack of data (or, more specifically, data describing some relationships and not others). Another significant reason for using OMT is the desire for an implementation-independent design. That is, it is important to have a sound conceptual framework that is founded in the disaster recovery literature that can serve as a guide for multiple approaches to computer simulation. A strong conceptual model will also serve other likely objectives, such as constructing a related database system or providing educational aids for students or decision makers. An object-oriented design may also facilitate an object-oriented implementation, which has benefits of modularity and encapsulation. With modularity, once the simulation objects, such as communities or neighborhoods, are designed and implemented, it is simple to create multiple objects and model the interactions (e.g., multiple interacting communities). With encapsulation, the function of an object can be modified, say as new data or equations become available, with little or no revision to the overall simulation.

The steps of OMT are (1) problem definition, (2) object (static) modeling, (3) dynamic modeling, and (4) functional modeling. The goal of defining the problem is to identify all of the objects and relationships that exist within the system, which can be abstracted during subsequent stages of analysis. An object model captures the static structure of a system by showing the objects in the system, relationships between objects, and the attributes and operations that characterize each class of objects. Dynamic modeling is not needed for purely static systems (i.e., a database) or computational systems, but rather for interactive software systems. (The dynamic model is not presented or discussed here because it is intended to assist later design of a spatial decision support system and has no effect on the simulation functionality.) The functional model describes the computations within a system in a general way.

The two most effective approaches to developing a detailed, unambiguous problem statement is to either write a requirements document of the model or compose a narrative of the real world system being modeled. The former approach is primarily suited to software development. The latter approach was adopted here, based on the literature review described in Section 2, which was distilled into a short narrative describing the events and interactions during an earthquake disaster (see Appendix A).

## **4.2 Static Model**

An object model captures the static structure of a system by showing the objects in the system, relationships between objects, and the attributes and behaviors that characterize each class of objects. An object can be anything that makes sense to the particular application: typically a concept, abstraction, or physical thing with well-defined boundaries. Objects should be chosen to promote understanding of the modeled system (i.e., disaster recovery) and provide a sound basis for computer implementation.

The initial step in creating the object model was identifying important objects from the problem narrative. Once potential objects were listed, some were discarded if they were beyond the current scope or better represented as attributes of or relationships between other objects. The potential objects were analyzed to determine what, if any, associations exist among the objects. (For example, a community contains one or more neighborhoods, which contain one or more households and businesses.) With a short list of potential objects and their associations, the problem narrative was used to help determine important attributes of each object (e.g., the size and sector of a business). Additional attributes of objects were obtained by considering likely decision variables, which may not necessarily be associated with any particular object. One design choice involved representing associated physical and economic objects (e.g., electric network and electric company, respectively) as a single economic object with attributes and functions that represent the important aspects of the associated physical object.

The static aspects of the conceptual model of disaster recovery are represented by the diagram in Figure 4-1. The diagram describes the important object types of the conceptual model and lists the attributes and functions of each type of object. So, for example, an object of type “household” has attributes of income (*INC*), year building of

residence was built (*BYR*), and whether any building mitigation has been done (*BMIT*). Within an implementation of the conceptual model there may be any number of households having the same data structure, but with different values for the respective attributes (and thus different output for the respective functions). The functional dependencies listed in Figure 4-1 were determined in the functional modeling step described below. The diagram shown is a simplified version of the object model developed and eventually implemented. Some secondary objects and associations are not shown. For example, the diagram does not show the inheritance association between households and businesses, which are both economic agents and have many similar attributes and functions.

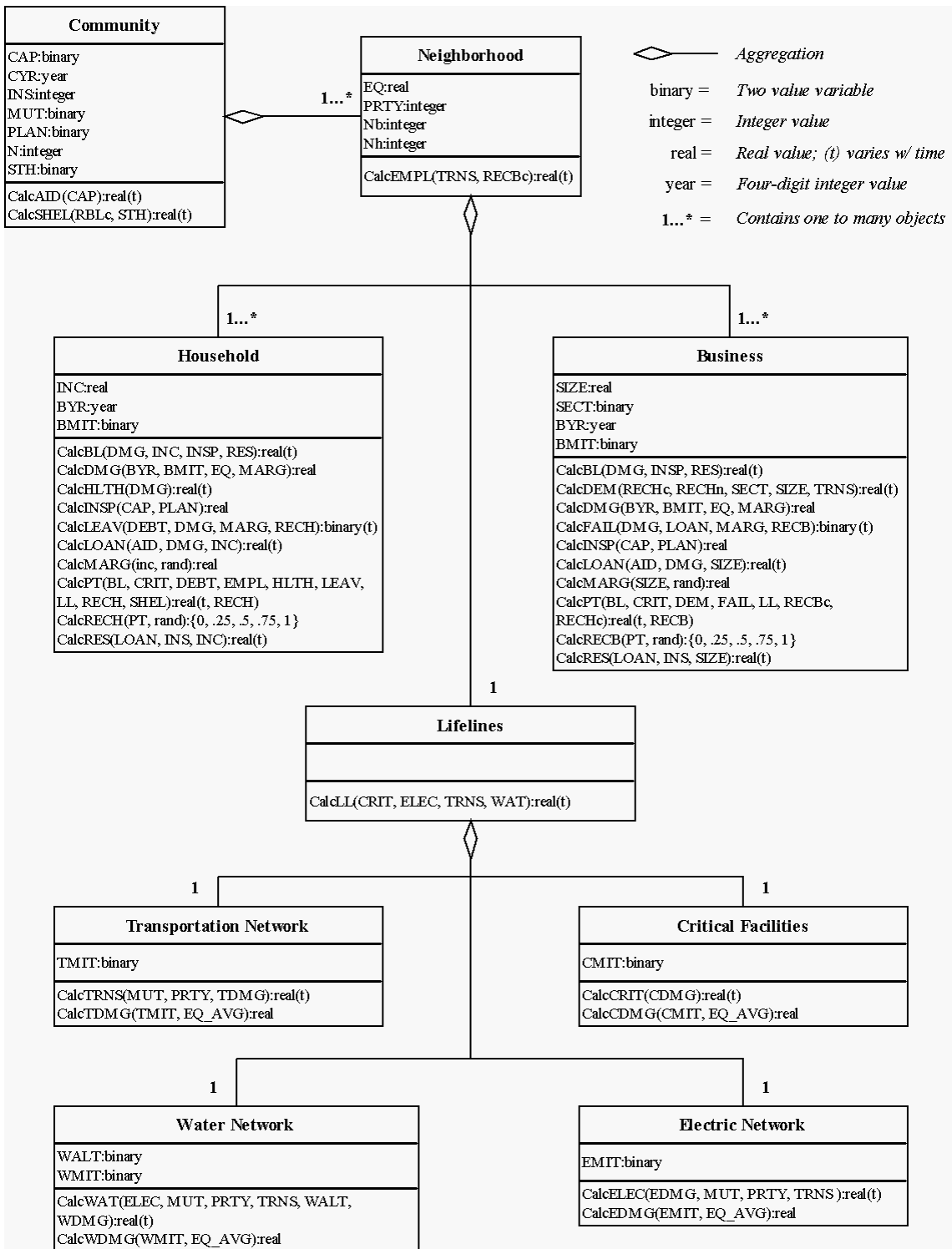

**Figure 4-1. Main objects in conceptual model. The three parts of each box respectively indicate the object's name, attributes, and behaviors or functions.**

### **4.3 Functional Model**

The functional model shows how output values are derived from input values, without regard to the order in which these values are computed. The functional model specifies the meaning of the functions in the object model (Section 4.2). Where the object model is represented using an object diagram, a function model is typically represented using a data flow diagram. The data flows represent object attributes that are passed between the functions of the different objects.

To develop the functional model, the most important top-level inputs (e.g., decision variables) and outputs (e.g., recovery indicators) were identified. The overall inputs that were not already specified as attributes were assigned to an appropriate object in the object model. As in the object modeling step, an effort was made to reduce the number of top-level inputs and outputs. This was done primarily by eliminating similar variables or creating proxy variables in place of related variables. Intermediate outputs that are necessary to map the top-level inputs to the top-level outputs were then considered. This was greatly assisted by referring to the potential attribute list of each object and finding those that vary with time (e.g., a household's health after a disaster). These intermediate outputs were then assigned as functions to the appropriate objects (e.g., *CalcHLTH* to household objects). Functional dependencies (i.e., what inputs are needed to derive a particular output) were arrived at with reference to the literature, the problem narrative, and common sense.

The functional dependencies within the disaster recovery conceptual model are illustrated in the flow diagrams of Figure 4-2 through Figure 4-5. Figure 4-2 illustrates the data flow required in assessing lifeline availability within a given neighborhood. The flow diagram clearly conveys the interconnectedness of the components that make up a community's lifeline network. Figure 4-3 describes the data flow requirements for determining the recovery of an individual business within a given neighborhood. The blocks related to lifeline mitigation are in bold to help illustrate the potential effects of lifeline availability on business recovery. (This is referred to later in Section 6.) The flow diagram for household recovery (Figure 4-4) is similar to the one for business recovery, with respective differences in variables. Figure 4-5, which is referenced by Figure 4-3 and Figure 4-4, indicates the functional relationships for determining building



damage severity. Notice that the flow diagrams (and, thus, the conceptual model) do not specify the numerical equations for each function (ellipses). This modularity is important so that it can be carried over to the implementation of the simulation model. In this way, existing equations or algorithms can be used or experimented with without affecting the overall structure or function of the simulation.

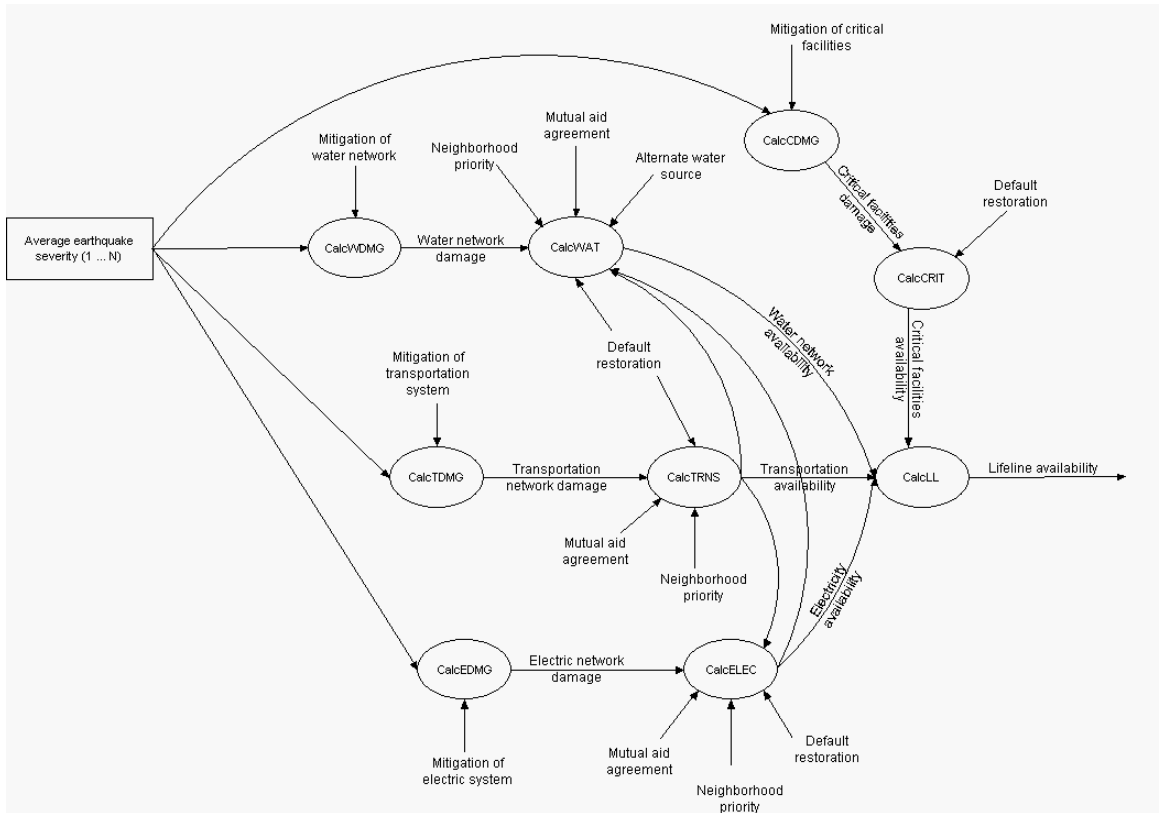

**Figure 4-2. Flow diagram for lifeline availability showing relationships of function inputs and outputs.**

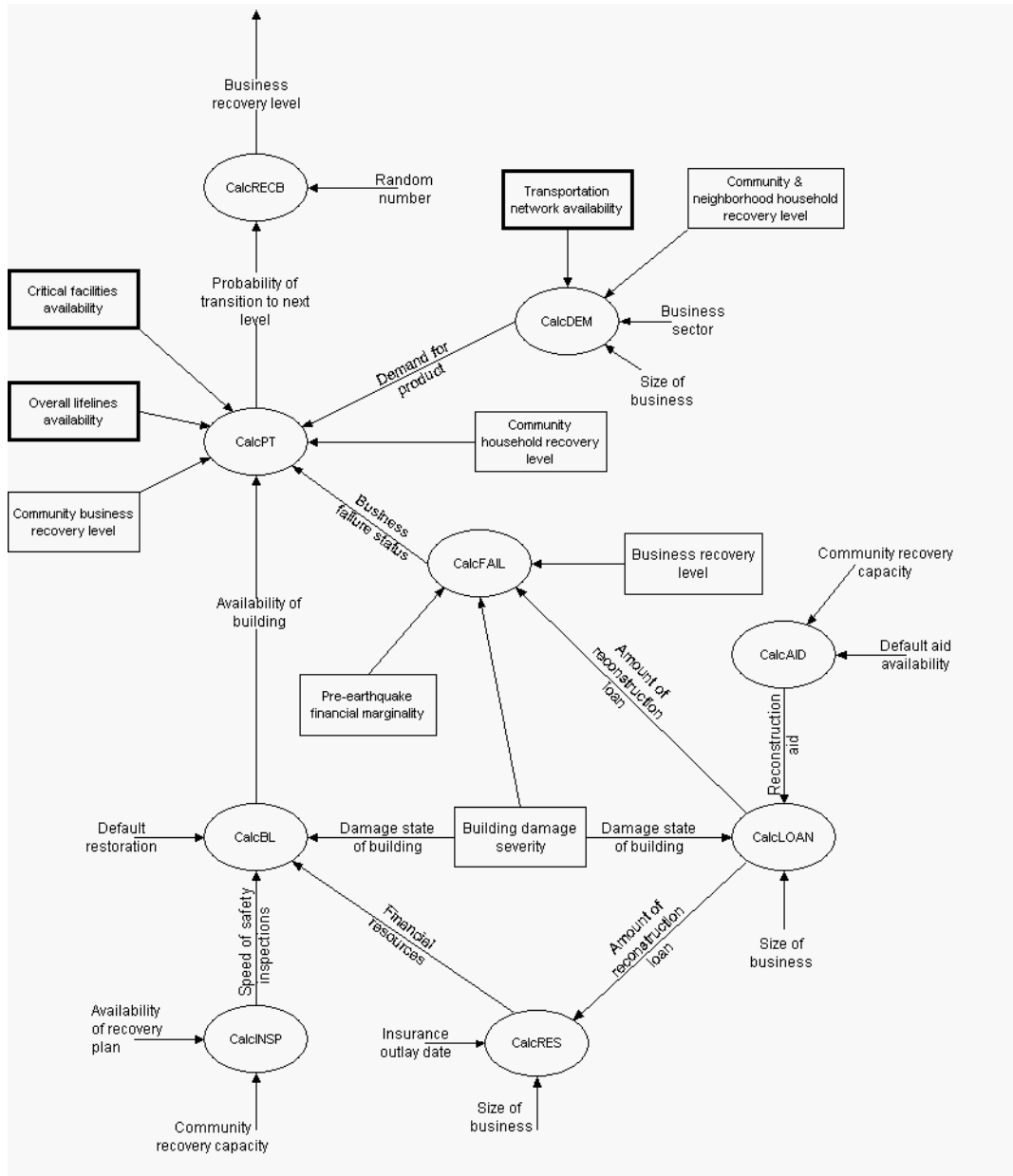

**Figure 4-3. Flow diagram for business recovery showing relationships of function inputs and outputs.**

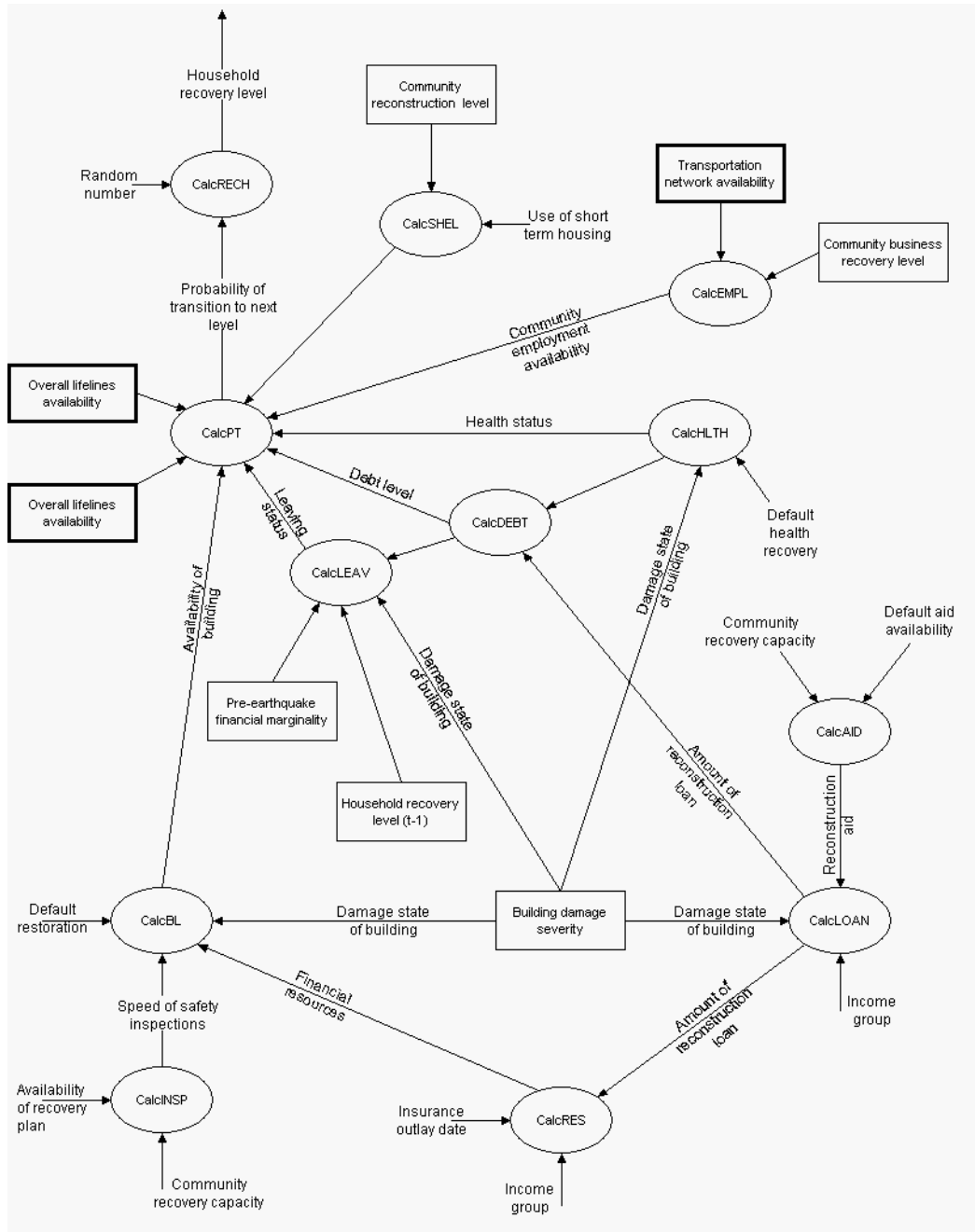

**Figure 4-4. Flow diagram for household recovery showing relationships of function inputs and outputs.**

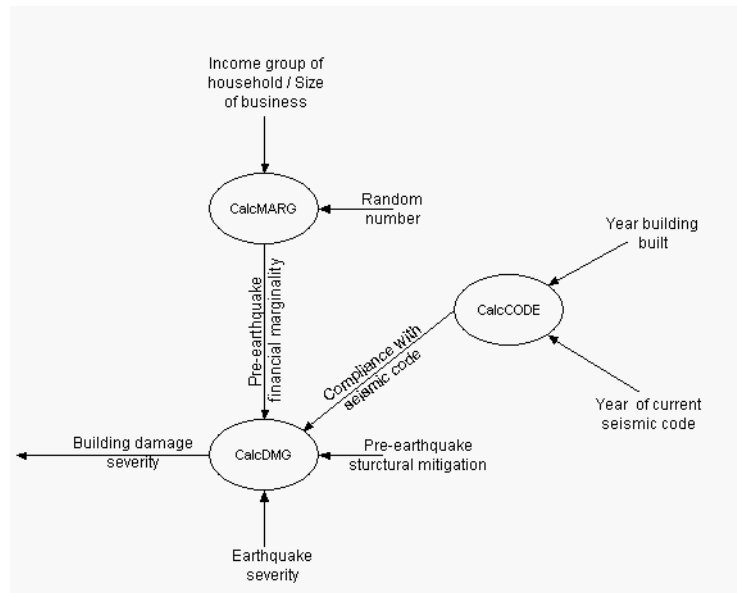

**Figure 4-5. Flow diagram for building damage severity showing relationships of function inputs and outputs.**

The functional model describes five principal types of recovery influences and processes that are useful in organizing and explaining the relationships expressed by the numerical framework. The five types are: (1) dynamic processes; (2) agent-attribute influences; (3) interaction effects; (4) spatial feedbacks; and (5) policy effects. Dynamic processes refer here to changes over time. In true dynamic processes, a variable's current level depends upon its level in a previous period. What can be called pseudo-dynamic processes – changes over time that can proceed independently of variable levels in previous periods – also play an important role.

In addition to temporal processes, a second main type of recovery influence consists of agent-attribute effects. For example in Figure 4-3, attributes of the business or household itself may influence its recovery trajectory pertaining to the post-earthquake demand for a business's product. (Note that product demand is one of the factors influencing the probability of transition to the next recovery level.) Product demand depends upon on a business's attributes – whether it is in a locally-oriented or export-oriented sector and whether it is a large or small business. In particular, if locally-

oriented, then the recovery of households in the neighborhood and community matters, as these are its customers. Similarly, local transportation conditions influenced locally-oriented business's product demand. However, if a business is export-oriented, these local variables do not play a role and the demand for its product remains unchanged by the disaster.

A third type of recovery influence consists of interaction effects. For example, in Figure 4-2, water availability is influenced by the survival of the electric power and transportation systems. Electric power may be needed to drive pumps that enable the water system to function; transportation disruption can impede the ability of the water utility to make repairs in a timely manner. Similarly, the relationships driving business product demand described in Figure 4-3 demonstrate some of the ways in which households, businesses, neighborhoods, and the community as a whole interact. Households influence business recovery through consumption demand. The availability of lifelines and critical facilities influence business recovery, as does the overall recovery level of households and businesses in the economy.

The fourth type of influence, spatial feedbacks, can similarly be seen in the examples presented so far. Households and businesses do not exist aspatially, but are affected by conditions in their specific neighborhoods, whether in terms of water availability, transportation conditions, or local consumer demand. Thus, the same type of household or business may recover differently depending upon which neighborhood it is located in (see Figure 4-4 and Figure 4-3).

The final type of influence consists of policy or decision effects. These are community-level decisions made either before the event, such as emergency planning and mitigation measures, or afterwards, such as recovery policy decisions. Figure 4-2 illustrates the influence of decisions regarding mutual aid and neighborhood prioritization on lifeline availability. Other decisions that are modeled include the year that the community put into effect a seismic design code for its buildings (if it did); emergency planning for alternative water supplies such as water trucks; whether or not seismic mitigations had been conducted for lifeline systems; the availability of a restoration and recovery plan; reliance on short-term housing in this plan; and a broadly defined variable

indicating the community's capacity for recovery (a proxy for the community's degree of integration and consensus). Modeling the influence of these decisions are critical in that implementation of the conceptual model will enable "what if" explorations of the recovery consequences for different policy decisions.

## Section 5

### Simulation Implementation

#### **5.1 Numerical Framework**

One goal of the work to-date has been to determine whether a recovery simulation is both feasible and useful. For this reason, we devised a simple numerical framework to facilitate implementing the many relationships of the functional model. The variables and relationships of the numerical framework are specified by the functional model described in Section 4.3. The framework takes the form of a series of simultaneous equations. Operationalizing the diverse relationships of the functional model was done by specifying each model variable as a relative index that varies between 0 and 1, rather than in real world metrics, such as dollars. In many cases, the model variables do not have a common metric, for example financial marginality or health. The approach taken is useful for integrating many metrics that would otherwise be difficult to mathematically combine. With each variable varying between 0 and 1, it was relatively simple to create basic first-order algebraic equations based on the functional model. In the future, to incorporate, for example, an existing equation into the simulation for determining the dollar amount of loans likely to be taken out by a household, it would only be necessary to determine a way of normalizing the output.

#### **5.2 Simulation Equations**

All of the equations that serve to operationalize the conceptual model are listed in this section. Each equation corresponds to a function described within the static model (Figure 4-1) and the same function represented by an ellipse in the functional model (Figure 4-2 to Figure 4-5). The equations further describe the relationships in the conceptual model by indicating whether influences are positive or negative and what the proportion of influence is with respect to other variables. Because of the number and relative simplicity of the simulation equations, individual explanations are not given for each equation. (A discussion of the function relationships was given in Section 4.3.) Definitions of each simulation variable are given in the following subsection. Subscripts in the simulation equations are defined as follows:  $b$  refers to a particular business,  $h$

refers to a particular household,  $n$  refers to a particular neighborhood,  $c$  refers to the particular community or city, and  $t$  refers to a particular time step (typically measured in weeks). Lastly, the abbreviation “*sat*” shown in brackets within simulation equations indicates that the result of the particular (part of the) equation saturates at a maximum value of one.

### 5.2.1 Variable Definitions

To reduce redundancy in explaining the simulation equations, the full set of variables are listed and defined in Table 5-1. Simulation variables can be of five different types: (1) agent attributes, (2) decision/policy variables, (3) intermediate indicators, (4) recovery indicators, and (5) driving variables. Variables belonging to the first four types were identified during the conceptual modeling stage (Section 4). However, several variables within the model implementation do not correspond with real-world input or decision variables. Instead, these parameters are used to drive the simulation by relating a particular variable (e.g., *HTLH*: health recovery) to time with a restoration curve. For simplicity all restoration curves were assumed to be linear curves having some assumed or calibrated slope. These slope values are modified within the simulation equations based on decision/policy variable values (e.g., for *MUT*, *CAP*, and *PRTY*). These driving variables are necessary as part of the implementation because none of the model inputs are time series data.



**Table 5-1. Variable definitions for conceptual framework.**

<b>AID</b>	= availability of reconstruction aid in community
<b>BLb</b>	= availability of building for use, businesses
<b>BLh</b>	= availability of building for use, households
<b>BMIT</b>	= pre-earthquake structural mitigation
<b>BYR</b>	= year building built
<b><u>CAP</u></b>	= recovery capacity of community (proxy for integration, consensus)
<b>CDMG</b>	= extent of damage to critical facilities
<b><u>CMIT</u></b>	= pre-earthquake mitigation to critical facilities
<b>CODE</b>	= compliance of building with seismic code
<b>CRIT</b>	= availability of critical facilities
<b><u>CYR</u></b>	= year seismic code effective
<b><i>DAID</i></b>	= driving variable: aid availability status
<b><i>DBLb</i></b>	= driving variable: building repair status, businesses
<b><i>DBLh</i></b>	= driving variable: building repair status, households
<b><i>DCRIT</i></b>	= driving variable: critical facility availability
<b>DEBT</b>	= extent of indebtedness
<b><i>DEL</i></b>	= driving variable: electricity availability
<b>DEM</b>	= demand for product post-earthquake
<b><i>DHLTH</i></b>	= driving variable: health restoration curve
<b><i>DINS</i></b>	= driving variable: availability of insurance
<b>DMG</b>	= damage state of building
<b><i>DTRNS</i></b>	= default transport accessibility
<b><i>DWAT</i></b>	= default water availability
<b>EDMG</b>	= extent of damage to electricity network
<b>ELEC</b>	= availability of electricity
<b><u>EMIT</u></b>	= pre-earthquake mitigation to electric power system
<b>EMPL</b>	= availability of employment/income
<b>EQ</b>	= severity of earthquake's physical effects
<b>FAIL</b>	= occurrence of business failure
<b>INC</b>	= income group of household
<b>INSP</b>	= speed of safety inspections
<b>LEAV</b>	= status of household leaving region
<b>LL</b>	= overall lifeline availability status
<b>LOAN</b>	= amount of reconstruction loan taken out
<b>MARG</b>	= pre-disaster financial marginality, proxy for building condition
<b><u>MUT</u></b>	= provision for mutual aid in restoration plan
<b><u>PLAN</u></b>	= availability of restoration and recovery plan
<b><u>PRTY</u></b>	= restoration priority accorded to neighborhood
<b>PT</b>	= probability of transition to next higher recovery level
<b><i>RBL</i></b>	= overall physical reconstruction
<b><i>RECb</i></b>	= business economic recovery level
<b><i>RECh</i></b>	= household economic recovery level
<b><i>RECB<sub>c</sub></i></b>	= overall business recovery in community (proxy for suppliers)
<b><i>RECH<sub>c</sub></i></b>	= overall household recovery in community (proxy for labor)
<b>RES</b>	= financial resources for recovery
<b>SECT</b>	= type of business sector
<b>SHEL</b>	= availability of temporary shelter
<b>SIZE</b>	= business size
<b><u>STH</u></b>	= reliance on short-term housing provision in recovery plan
<b>TDMG</b>	= extent of damage to transport network
<b><u>TMIT</u></b>	= pre-earthquake mitigation to transportation system
<b>TRNS</b>	= transportation accessibility
<b><u>WALT</u></b>	= provision for alternate water sources (water trucks) in plan
<b>WAT</b>	= availability of water
<b>WDMG</b>	= extent of damage to water network
<b><u>WMIT</u></b>	= pre-earthquake mitigation to water system

Notes: Agent attributes in **bold**. Decision variables in **bold underline**. Driving variables in ***bold italics***. Recovery indicators in ***italic underline***.

## 5.2.2 Business Functions

In the model, the recovery level for business  $b$  at any time  $t$  depends upon the recovery level in the previous time period and the probability of transition ( $PT$ ) from that level to the next (Equation 5-1). The probability of transition in turn depends upon the restoration status of lifelines ( $LL$ ) and critical facilities ( $CRIT$ ), buildings ( $BL$ ), and economic demand ( $DEM$ ), as well as the overall recovery level of businesses ( $RECB$ ; here, a proxy for suppliers) and households ( $RECH$ ; here, a proxy for labor) in the community (Equation 5-2). The selection of these variables and the numerical specification of the equations were based on the empirical literature reviewed above, as well as some experimentation with early versions of the model.

$$RECB_b(t) = 0.25((PT_b \geq x) + RECB_b(t-1)[sat]) \quad (5-1)$$

$$PT(t) = \begin{cases} 0 & , \text{if } FAIL_b(t) = 1, RECB_b(t-1) > 0 \\ 0.5(CRIT_c + LL_c) & , \text{if } REC_b(t-1) = 0 \\ 0.333 \sqrt{DEM_b} (\sqrt{BL_b} + \sqrt{LL_c} + \sqrt{CRIT_c}) & , \text{if } REC_b(t-1) = 0.25 \\ 0.2 \sqrt{DEM_c} (BL_b + LL_c + CRIT_c + RECB_c + RECH_c) & , \text{if } REC_b(t-1) = 0.5 \\ 0.25 DEM_b (0.45BL_b^2 + LL_c^2 + RECB_c^2 + RECH_c^2) & , \text{if } REC_b(t-1) = 0.75 \\ 1 & , \text{if } REC_b(t-1) = 1.0 \end{cases} \quad (5-2)$$

The status of buildings follows a default reconstruction curve ( $DBL$ ) that is modified by factors such as the speed of inspections ( $INSP$ ), financial resources ( $RES$ ), and extent of damage ( $DMG$ ) (Equation 5-3). Post-disaster economic demand for the business' product depends upon the business' sector ( $SECT$ ) and size ( $SIZE$ ) and transportation conditions ( $TRNS$ ). If the business is locally-oriented, household recovery conditions ( $RECH$ ) are also influential (Equation 5-4). Building damage depends upon the severity of the earthquake ( $EQ$ ), the financial marginality of the business occupant ( $MARG$ ), mitigation history ( $BMIT$ ), and the year the structure was built ( $BYR$ ) relative to the year seismic codes were introduced ( $CYR$ ) (Equation 5-5).

$$BL_b(t) = DBL(t)(INSP_c + RES_b) + (1 - DMG_b) \quad [sat] \quad (5-3)$$

$$DEM_b(t) = \begin{cases} 0.5(SIZE_b + TRNS_n) [sat], & SECT = 1 \\ 0.25(SIZE_b + TRNS_n + RECH_n(t-1) + RECH_c(t-1)) [sat], & SECT = 0 \end{cases} \quad (5-4)$$

$$DMG_b = \begin{cases} 0.333(1 + EQ_n + MARG_b - ((BYR_b \geq CYR_c) \cup BMIT_b)), & EQ \neq 0 \\ 0, & EQ = 0 \end{cases} \quad (5-5)$$

Businesses can fail. Their survival or failure (FAIL) is influenced not only by the extent of building damage, but also by their recovery timepath, financial marginality, and indebtedness status (LOAN) (Equation 5-6). The latter is, in turn, related to the availability of disaster assistance (AID), the severity of damage suffered, and the business' size (Equation 5-7). Pre-disaster financial marginality is more likely in the case of small businesses (Equation 5-8). Similarly, available financial resources are dependent upon business size, indebtedness, and the availability of insurance (*DINS*).

$$FAIL_b(t) = \begin{cases} 1, FAIL_b(t-1) = 1 \\ 1, 0.25DMG_b(MARG_b + LOAN_b(t-1) + (1 - RECB_b(t-1)) + (1 - RECB_b(t-2))) > 0.65 \\ 0, \dots \leq 0.65 \end{cases} \quad (5-6)$$

$$LOAN_b(t) = AID_c(t) \cdot DMG_b(1 - SIZE_b) \quad [sat] \quad (5-7)$$

$$MARG_b = 1 - (SIZE_b \cdot rand) \quad (5-8)$$

$$RES_b = (0.25 - 0.25SIZE_b)LOAN_b + 0.5SIZE_b + 0.5SIZE_b \cdot DINS(t) \quad (5-9)$$

### 5.2.3 Household Functions

The recovery status of household *h* (*RECH*) is similarly related to its recovery status in the previous time period and recovery transition probabilities (Equation 5-10). The transition probability depends upon household-level factors such as health (*HLTH*), housing damage status (*BL*), and indebtedness

(*DEBT*), as well as community-level factors such as lifeline and critical facilities restoration, the availability of shelters (*SHEL*) and jobs availability (*EMPL*) (Equation 5-11). Again, the selection of these variables and the numerical specification of the equations were based on the empirical literature reviewed above, as well as some experimentation with early versions of the model. Building damage restoration is influenced by speed of inspections, financial resources, and income level (*INC*), as well as the initial physical damage (Equation 5-12). Indebtedness is related to damage, loan history, health history, and job opportunities in the community (Equation 5-13). Building damage is specified similarly to the case of businesses (Equation 5-14). Health is related to initial building damage (Equation 5-15). Households can leave the region if they fail to recover; this is dependent upon such factors as financial marginality, indebtedness, and the timepath of recovery (Equation 5-16). Indebtedness, financial marginality, and resource availability are determined similarly to the case of businesses, except that income levels exert an influence similar to that of business size (Equations 5-17~19).

$$RECH_h(t) = \begin{cases} 0.25((PT_h(t) \geq x) + RECH_h(t-1)), & RECH_h(t-1) < 1 \\ 1, & RECH_h(t-1) = 1 \end{cases} \quad (5-10)$$

$$PT_h(t) = \begin{cases} 0 & , \text{if } LEAV_h(t) = 1, RECH_h(t-1) > 0 \\ 0.333(CRIT_c + HLTH_h + SHEL_c) & , \text{if } REC_h(t-1) = 0 \\ 0.2\sqrt{EMPL_c}(\sqrt{BL_h} + LL_c + CRIT_c + HLTH_h + SHEL_c) & , \text{if } REC_h(t-1) = 0.25 \\ 0.25EMPL_c(BL_h + LL_c + HLTH_h + (1 - DEBT_h)) & , \text{if } REC_h(t-1) = 0.5 \\ 0.333EMPL_h^2(BL_h^2 + LL_c^2 + (1 - DEBT_h)^2) & , \text{if } REC_h(t-1) = 0.75 \\ 1 & , \text{if } REC_h(t-1) = 1.0 \end{cases} \quad (5-11)$$

$$BL_h(t) = DBL(t)(INSP_c + INC_h + RES_h) + (1 - DMG_h) \quad [sat] \quad (5-12)$$

$$DEBT_h(t) = 0.25(2 + DMG_h + LOAN_h(t-1) - HLTH_h(t-1) - EMPL_c(t-1)) \quad (5-13)$$

$$DMG_b = \begin{cases} 0.333(1 + EQ_n + MARG_h - ((BYR_h \geq CYR_c) \cup BMIT_h)), & EQ_n \neq 0 \\ 0, & EQ_n = 0 \end{cases} \quad (5-14)$$

$$HLTH_h(t) = DHLTH(t) + 1 - DMG_h \quad [sat] \quad (5-15)$$

$$LEAV_h(t) = \begin{cases} 1, & LEAV_h(t-1) = 1 \\ 1, & 0.25DMG_h(MARG_h + DEBT_h(t-1) + (1 - RECH_h(t-1)) + (1 - RECH_h(t-2))) > 0.65 \\ 0, & \dots \leq 0.65 \end{cases} \quad (5-16)$$

$$LOAN_h(t) = AID_c(t) \cdot DMG_h(1 - INC_h) \quad [sat] \quad (5-17)$$

$$MARG_h = 1 - (INC_h \cdot rand) \quad (5-18)$$

$$RES_h(t) = (0.25 - 0.25INC_h)LOAN_h(t-1) + 0.5INC_h + 0.5INC_h \cdot DINS(t) \quad (5-19)$$

#### 5.2.4 Community Functions

Several variables that affect business and household recovery are determined at the community level. The availability of disaster assistance follows a default timepath that can be speeded up if the community has a strong capacity for recovery (*CAP*) (Equation 5-20). This general concept has been identified in the literature as related, for example, to the strength of horizontal and vertical integration within the community (Berke et al., 1993). The availability of temporary shelter after the disaster is related to both the extent of overall building reconstruction (*RBL*) and the reliance on short-term housing provision in the community's disaster recovery plan (*STH*) (Equation 5-21). Employment availability depends upon both overall business recovery levels in the community and the status of transportation repairs (Equation 5-22). The speed of inspections is positively influenced by both community recovery capacity and the existence of an effective community disaster recovery plan (*PLAN*) (Equation 5-23).

$$AID_c(t) = DAID(t)(1 + CAP_c) \quad [sat] \quad (5-20)$$

$$SHEL_c(t) = (STH_c - RBL_c(t-1) + 1) \quad (5-21)$$

$$EMPL_c(t) = 0.25TRNS_c(t) + 0.75RECB_c(t - 1) \quad (5-22)$$

$$INSP_c = 0.5(CAP_c + PLAN_c) \quad (5-23)$$

### 5.2.5 Neighborhood and Lifeline Functions

As noted previously, lifeline restoration plays a central role in recovery. This is mostly evaluated at the neighborhood level. Overall lifeline restoration is an aggregation of that of individual lifelines (transportation, electric power, and water), as well as critical facilities such as hospitals (Equation 5-24). The latter follows a default timepath (*DCRIT*) that is modified by the extent of damage suffered (*CDMG*) (Equation 5-25), which in turn is related to average ground shaking levels across the neighborhood (*EQ\_AVG*) and whether or not seismic mitigations have been implemented at the critical facilities (*CMIT*) (Equation 5-26).

$$LL_n(t) = 0.25(TRNS_n(t) + ELEC_n(t) + WAT_n(t) + CRIT_n(t)) \quad (5-24)$$

$$CRIT_n(t) = DCRIT(t) + (1 - CDMG_n(t)) \quad [sat] \quad (5-25)$$

$$CDMG_n = \begin{cases} 0, & EQ\_AVG = 0 \\ 0.5(EQ\_AVG - CMIT_n + 1), & EQ\_AVG > 0 \end{cases} \quad (5-26)$$

Electric power restoration in a neighborhood also follows a default timepath (*DEL*). This is modified by the extent of physical damage (*EDMG*) and transportation restoration, which affects the ability of crews to make repairs, as well as such policy or planning variables as the existence of mutual aid agreements (*MUT*) and whether or not the particular neighborhood has been given high priority in the restoration strategy (*PRTY*) (Equation 5-27). Damage is determined by ground shaking and whether seismic mitigations have been implemented (*EMIT*) (Equation 5-28). Transportation restoration and damage are considered similarly to the respective equations for electric power (Equations 5-29 and 5-30).

$$ELEC_n(t) = DEL(t)(MUT_c + PRTY_n + TRNS_n(t)) + (1 - EDMG_n) \quad [sat] \quad (5-27)$$

$$EDMG_n = \begin{cases} 0, & EQ\_AVG = 0 \\ 0.5(EQ\_AVG - EMIT_n + 1), & EQ\_AVG > 0 \end{cases} \quad (5-28)$$

$$TRNS_n(t) = DTRNS(t)(MUT_c + PRTY_n) + (1 - TDMG_n) \quad [sat] \quad (5-29)$$

$$TDMG_n = \begin{cases} 0, & EQ\_AVG = 0 \\ 0.5(EQ\_AVG - TMIT_n + 1), & EQ\_AVG > 0 \end{cases} \quad (5-30)$$

Water restoration depends upon not only the default restoration curve (DWAT), initial damage (WDMG), mutual aid agreements and neighborhood prioritization, but also on the restoration status of transportation (for repair crews) and electric power restoration (for running pump stations), as well as on disaster plans for water trucks or other alternative sources of potable water (WALT) (Equation 5-31). Damage is determined similarly to the other lifelines (Equation 5-32).

$$WAT_n(t) = DWAT(t)(1 + WALT_c)(MUT_c + PRTY_n + TRNS_n(t) + ELEC_n(t)) + (1 - WDMG_n) \quad [sat] \quad (5-31)$$

$$WDMG_n = \begin{cases} 0, & EQ\_AVG = 0 \\ 0.5(EQ\_AVG - WMIT_n + 1), & EQ\_AVG > 0 \end{cases} \quad (5-32)$$

### **5.3 Computing Platform**

The Simulink modeling environment for Mathwork's MATLAB was chosen for implementing the recovery simulation (Figure 5-1). Simulink is specifically designed for implementing complex, time-based simulations using a graphical language consisting of operators (Simulink blocks) and data flows, which connect the blocks. This framework makes implementation of the recovery conceptual model relatively simple having constructed the data flow diagrams of the function model. Simulink affords significant advantages in terms of simulation building and execution, and robust capabilities for building graphical user interface elements. The greatest advantage of Simulink is probably the modularity it provides, which is compatible with an object-oriented design. Simulink allows models to be built in both a hierarchical and encapsulated manner, which greatly increases the organization and understandability of the simulation components. Once simulation components, such as a household, are designed and implemented with the specific attributes and operations, they can be saved in a library and duplicated to create large simulations. The simulation can be executed within the MATLAB command-line environment or within MATLAB programming scripts, which facilitates stochastic simulations or detailed sensitivity analyses. The disadvantages of Simulink include its high cost, the tediousness of assembling a large number of simulation components and, to a lesser extent, the initially cumbersome way in which flow control (e.g., IF-THEN) is implemented.



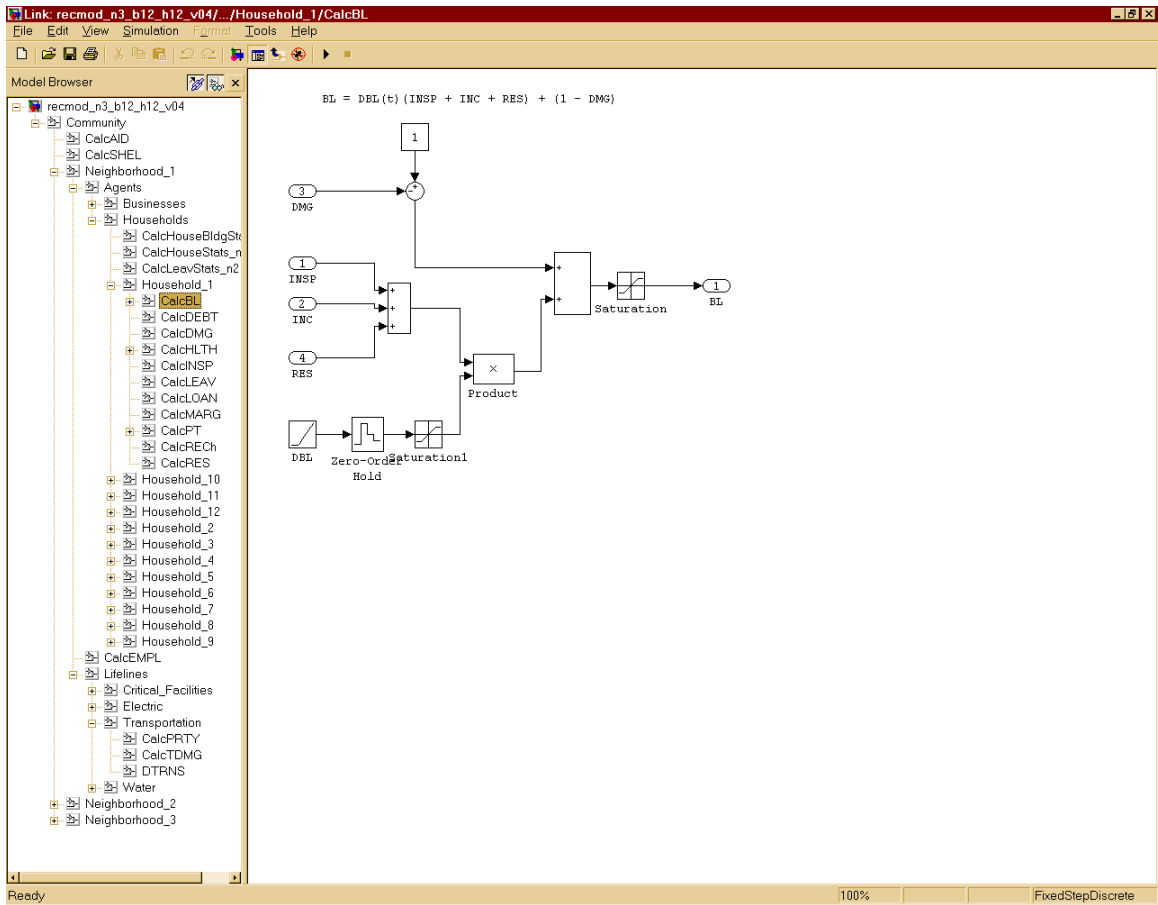

**Figure 5-1. Screenshot of simulation implementation using Simulink.**



## Section 6

### Test Application

#### 6.1 Analysis Scenario

The prototype simulation was applied to a hypothetical community to evaluate the conceptual model and numerical framework. The hypothetical community was designed and parameterized to reflect a high level of community planning and preparedness. As such, the community has a disaster response plan ( $PLAN = 1$ ), mutual aid agreements in place ( $MUT = 1$ ), and a reliance on short term housing ( $STH = 1$ ). The community is made up of three neighborhoods. The neighborhoods are located similarly with respect to the seismic hazard (e.g., fault line or rupture area), and thus experience the same earthquake shaking intensity. In this case, the earthquake severity is set to a maximum value for each neighborhood ( $EQ = 1$ ). The neighborhoods were also assigned equal priority for emergency response and post-disaster restoration ( $PRTY = 1$ ). Each neighborhood contains 12 households and 12 businesses (Figure 2-1). The demographics of the three neighborhoods are given in Figure 6-1. The demographics were chosen to generally represent “old core”, “new core” (downtown), and suburb neighborhoods. These are distinguished by the age mix of buildings (old, new), income distribution of households (low, medium, high), and sectoral (local, export) and size (small, large) distribution of businesses.

All else equal, certain loss and recovery trends are anticipated with respect to these demographic characteristics. Older buildings (and their occupants) are expected to fare worse than newer ones. Lower income households are expected to have more difficulty recovering than their higher income counterparts due to lesser access to financial and other resources. Locally-oriented businesses are anticipated to face greater challenges since their customer base is also impacted by the disaster. Smaller businesses are anticipated to have more problems recovering than larger businesses, again due to lesser access to financial resources.

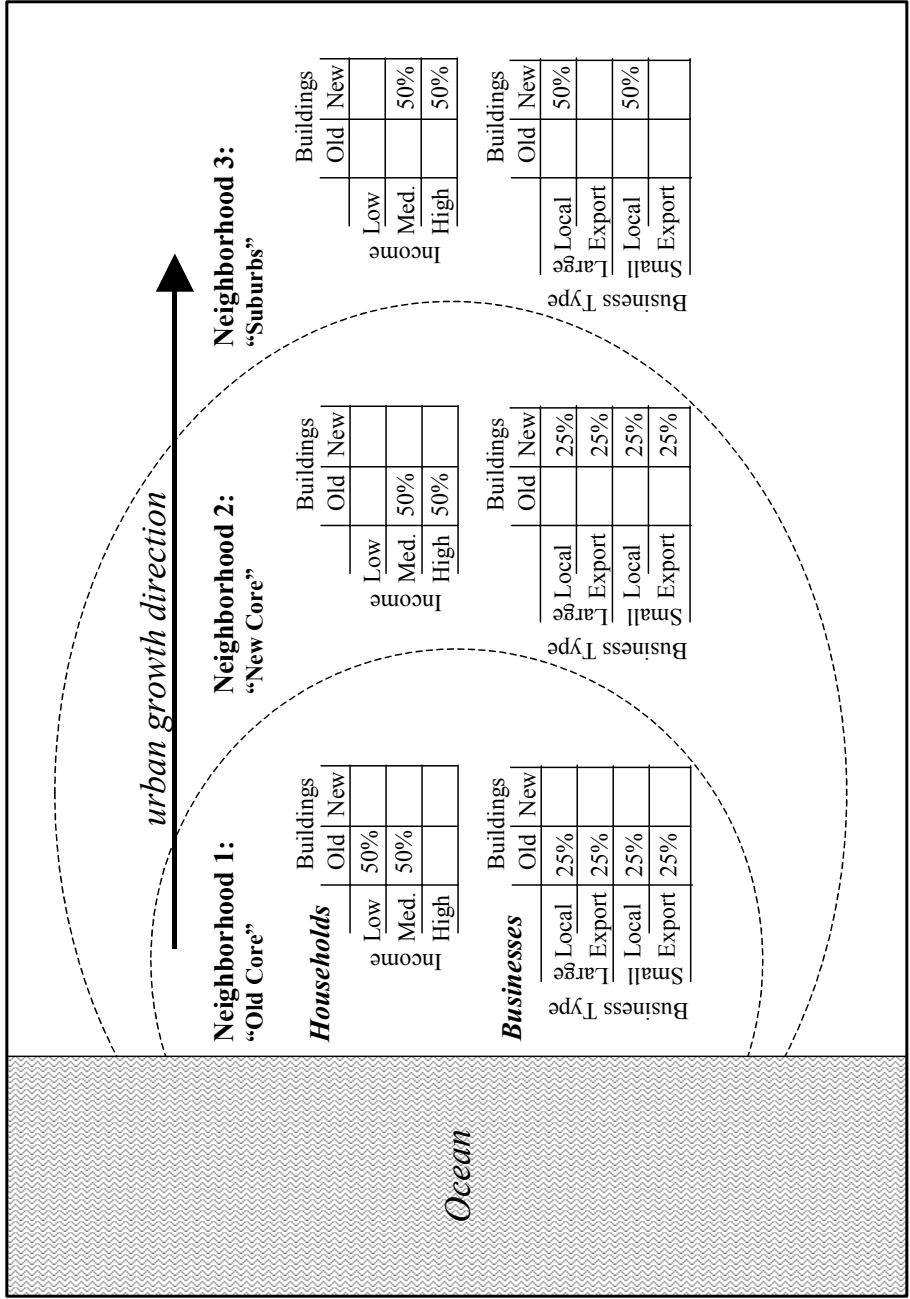
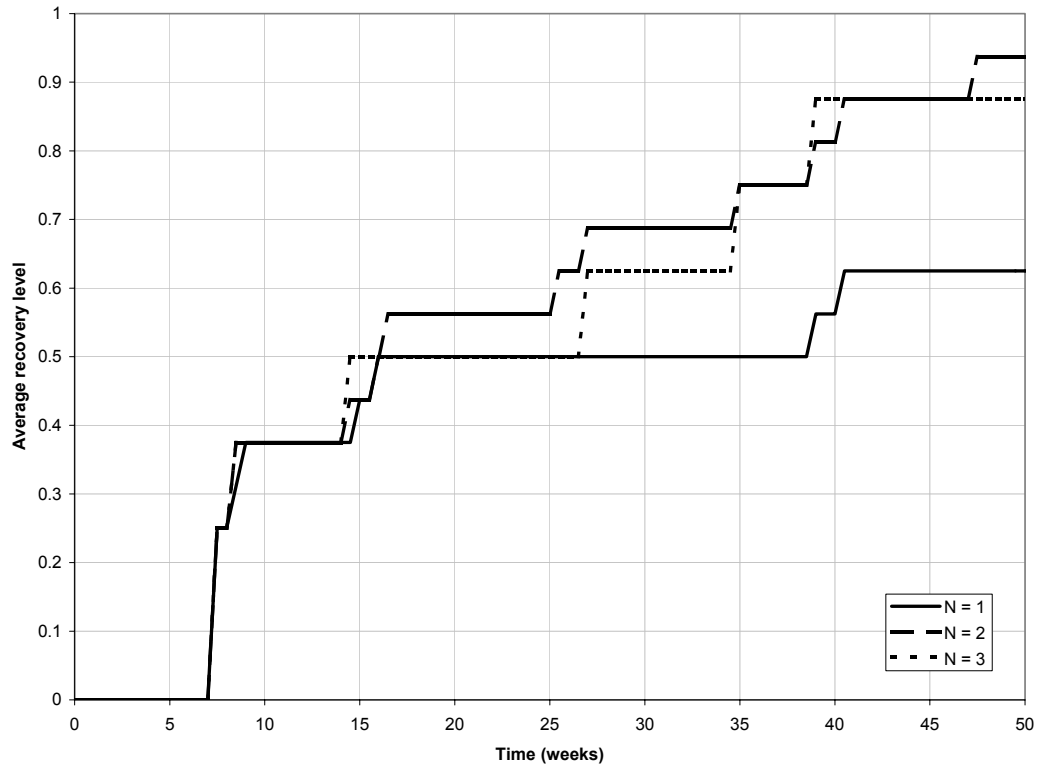

Figure 6-1. Household and Business Characteristics of Neighborhoods in Simulated City

The simulation parameters described above were held constant to demonstrate the effects of changing the values of lifeline mitigation variables. The simulation was run for two simple scenarios: (1) mitigation measures taken for all lifelines ( $TMIT=1$ ,  $EMIT=1$ ,  $CMIT=1$ ,  $WMIT=1$ ,  $WALT=1$  for all neighborhoods) and (2) no mitigation measures taken for any lifelines (same variables set to zero for all neighborhoods). (Figure 4-3, which describes the functional relationships for computing business recovery, illustrates the effects of changing lifeline mitigation variables.) For these scenarios, randomness was not implemented to better understand the sensitivity of changing the lifeline variables.

## **6.2 Analysis Results**

The simulation described in the previous subsection was parameterized and run using a programming script. As configured, the simulation takes about 2 minutes to run on an 850Mhz processor. The outputs of the two simulation scenarios described above are quite reasonable with respect to the influence of input variable values. The output of the simulated scenarios is summarized by the average business and household recovery level for each neighborhood, together with a listing of how many businesses failed or households left in each neighborhood. (The average recovery level is calculated by summing the recovery levels of each respective agent within the community – i.e., household or business – and dividing by the number of agents.) Figure 6-2 and Figure 6-3 describe the recovery of businesses and households, respectively, with no lifeline mitigation. Table 6-1 lists how many businesses failed and households left in each neighborhood.



**Figure 6-2. Average businesses recovery levels by neighborhood, “no mitigation” case.**

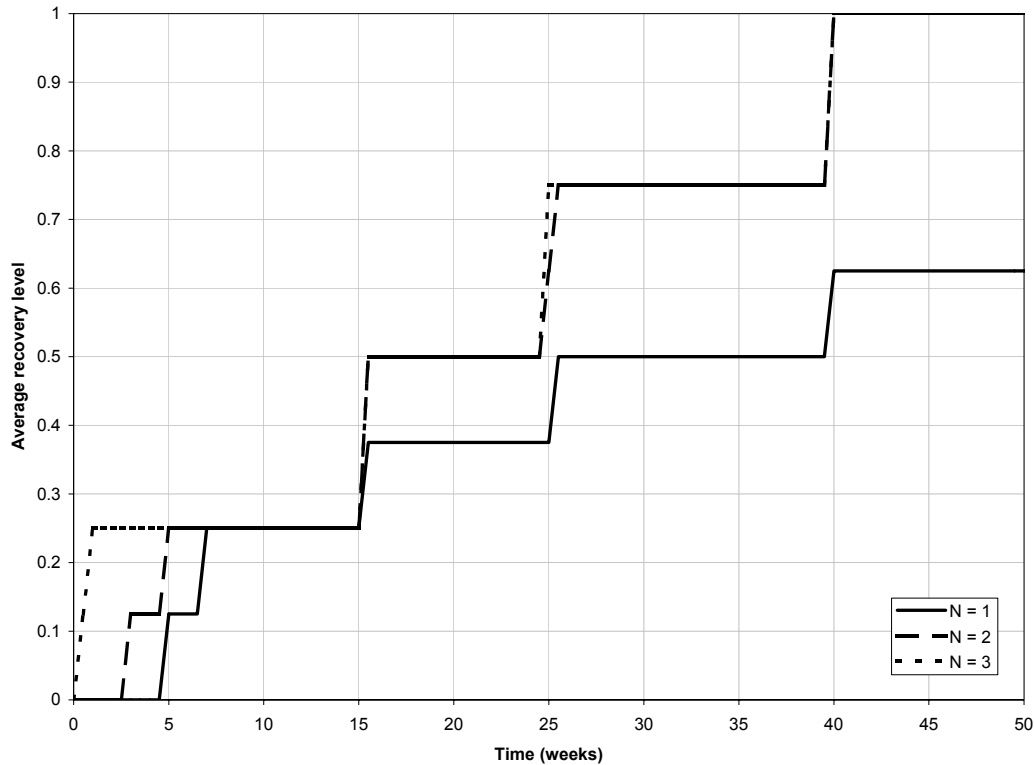

**Figure 6-3. Average household recovery levels by neighborhood, “no mitigation” case.**

It is easy to see how the different demographics of the three neighborhoods affect the business recovery levels (Figure 6-2). First, there is a slight lag between Neighborhoods 2 and 3. This reflects the fact that Neighborhood 3 has only businesses with local markets, while Neighborhood 2 contains businesses for a mix of sectors. In Neighborhoods 2 and 3, all of the businesses occupy new or retrofitted buildings. As a result, Neighborhood 2 and 3 reached a higher average business recovery level than Neighborhood 1, which has old or unretrofitted buildings that are more likely to be damaged. For similar reasons, no businesses failed in Neighborhood 2 and 3, whereas the six small businesses failed in Neighborhood 1 (Table 6-1). Business failures affect the average recovery level and prevent the level from reaching the maximum value of one in Neighborhood 1. In the case of Neighborhoods 2 and 3, the reason that the average recovery levels do not reach one is not entirely clear. It may be because Neighborhoods

2 and 3 contains small, local businesses that, because of the model algorithm, do not completely recover.

**Table 6-1. Results of Simulation, No Lifeline Mitigation Scenario**

<b>Neighborhood / sector</b>	<b>Result</b>
Neighborhood 1	
Businesses:	6 failed
Households:	6 left
Neighborhood 2	
Businesses:	0 failed
Households:	0 left
Neighborhood 3	
Businesses:	0 failed
Households:	0 left

The household recovery output for the scenario of “no lifeline mitigation” is similar to that of the business output. The slight lag, early on, between Neighborhood 2 and 3 is due to the difference in residential building characteristics. (The small lag might suggest that the model may not be sensitive enough to building attribute in some contexts.) In contrast, Neighborhood 1, which contains all old or unretrofitted houses, did not completely recover and the six low-income households left (Table 6-1). It is interesting to note that all three neighborhoods took several weeks to reach the first level of recovery. Likelihood of reaching the first level of recovery (*PT*) is a function of critical facilities recovery (*CRIT*), household health (*HLTH*), and whether or not shelter is available (or needed) (*SHEL*) (Equation 5-11).

Looking at the contrasting mitigation scenario, the effect of lifeline mitigation on the model output is readily apparent. Figure 6-4 and Figure 6-5 describe the recovery of businesses and households, respectively, in the case with lifeline mitigation. For both businesses and households, recovery time is significantly shorter. One of the most significant aspects of this is how much more quickly all businesses and households reached the first level of recovery. In addition, no businesses failed, nor did any households leave the area. For businesses recovery, the difference between the three neighborhoods is less obvious because of the overall speed of recovery. The effect of building type and mitigation can be seen in the slight lag in recovery of Neighborhood 1,



which has only old or unretrofitted buildings for its businesses, behind Neighborhood 2. The behavior of Neighborhood 3 is more difficult to interpret. The only indication that the neighborhood has only local business is the fact it does not reach the same maximum recovery level as the other neighborhoods. In the case of household recovery, the difference between neighborhoods is easily distinguished. This reflects the fact that each neighborhood is increasingly, from Neighborhood 1 to 3, less vulnerable. Interestingly, for this scenario, the time to the first recovery level is similar for each neighborhood, but quite different for the three higher levels.

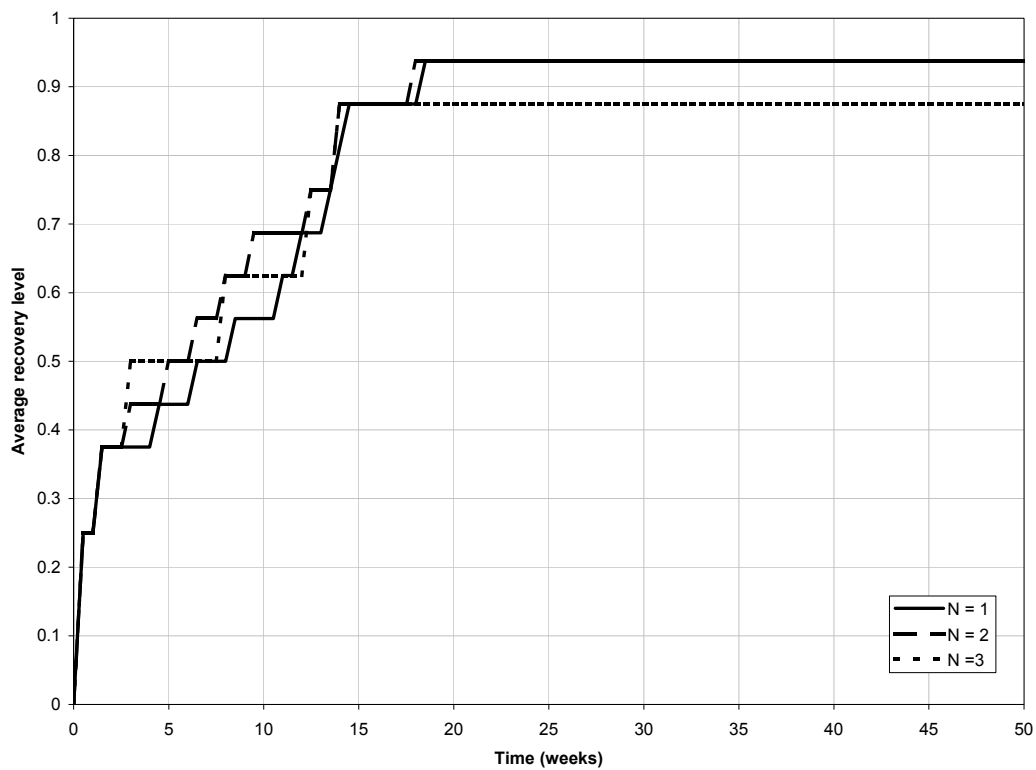

**Figure 6-4. Average businesses recovery levels by neighborhood, lifeline mitigation case.**

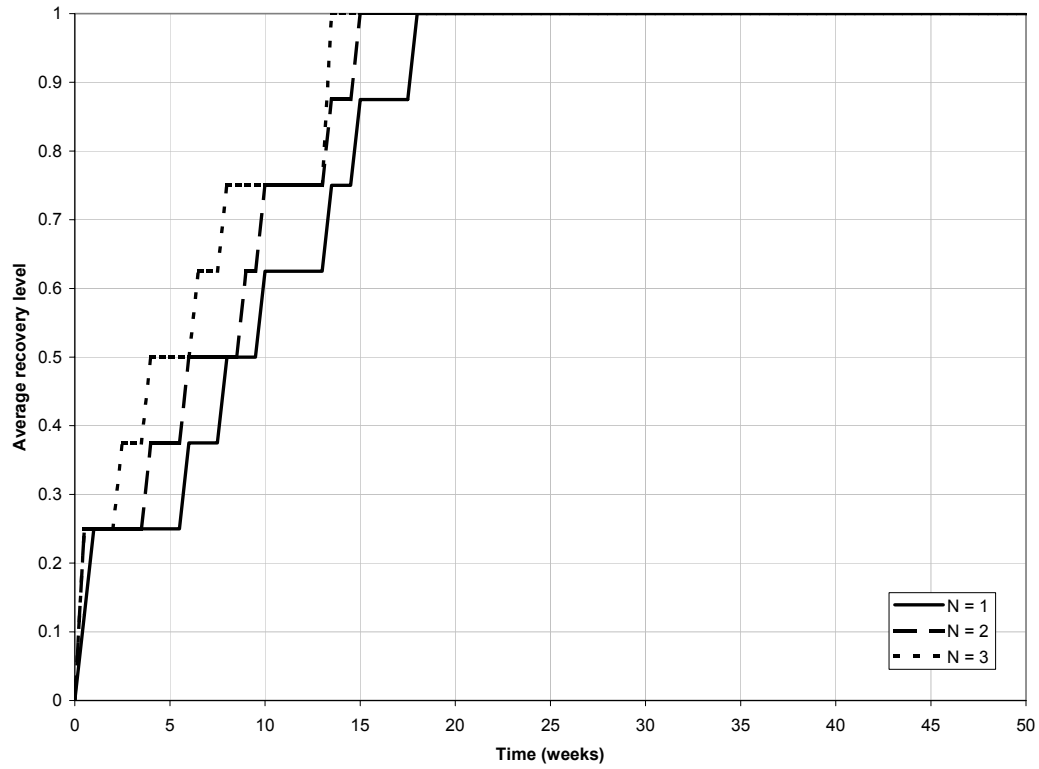

**Figure 6-5. Average household recovery levels by neighborhood, lifeline mitigation case.**

## Section 7

### Prototype Application: Base Model

In order to thoroughly evaluate the usability, suitability, and effectiveness of the disaster recovery simulation it is necessary to apply it to a real-world disaster. For the prototype application, we chose to simulate the recovery of the city of Kobe after the 1995  $M = 6.9$  earthquake and disaster. The Kobe earthquake is chosen for the prototype application because it is the most catastrophic urban earthquake disaster in recent history. Relatively good data has been collected and analyzed since the earthquake, including several studies by the senior author (Chang and Taylor, 1995; Chang, 1996, 2001; Chang and Nojima, 2001).

Modeling the recovery of Kobe provides a real-world exercise in collecting input data for the simulation and investigating the means of calibrating simulation driving variables. The simulation outputs can be compared with recovery indicators collected for Kobe. Because the recovery simulation is a prototype, we may not expect it to compare accurately with Kobe recovery indicators. However, the comparison will provide insight on the suitability of simulation outputs and whether simulation outputs are generally acceptable. This insight will form the foundation for further design and implementation. Having the simulation fully specified for a real event also provides an opportunity to explore the sensitivity of the simulation and to determine if the broad behavior of the simulation meets general expectations.

#### **7.1 Simulation Improvements**

Before the simulation could be applied to a larger scenario, it was necessary to modify the implementation to increase the flexibility of specifying inputs and decrease model runtimes. In the test implementation (Section 6), each household or business was represented by a copy of the simulation algorithms that process the scalar inputs for each agent (household or business). This approach replicates the conceptual model closely and so the simulation's organization is easy to comprehend. This also facilitates monitoring the behavior and outputs of each agent. Unfortunately, as the number of

agents and neighborhoods grows, this implementation becomes unwieldy and tedious to expand. Further, the model runtimes increase significantly with increasing input-output processing.

To make the simulation more flexible for different applications (sizes of communities), it is desirable that both the number of agents and number of neighborhoods be specified at runtime (rather than hard-coded into the simulation). For the prototype application, we concluded that the time and effort required to modify the simulation so that the number of neighborhoods could be specified at runtime was not practical. The current implementation of the simulation allows the number of households and businesses to be specified at runtime. Additionally, unlike the test implementation, the number of households and businesses in each neighborhood can be different (and the number of households and businesses do not need to be equal). This flexibility was primarily obtained by implementing dynamically sized matrices as inputs to the agent algorithms. (The algorithms are duplicated for each hard-coded neighborhood.) It should be noted that none of the simulation equations were changed by modifying the computer implementation.

The increased flexibility and simulation sizes makes specifying inputs potentially more tedious. Thus, the configuration script was revised to make specifying input demographics (agent attributes) easier. Rather than specifying the value for each variable of each agent, the relative number (percentage) of each demographic group is specified (e.g., Neighborhood X has 15% households with high incomes and retrofitted buildings). The script then generates the input values and formats them appropriately.

An intended side effect of increasing the flexibility of specifying model inputs was to decrease model runtimes. (MATLAB is optimized for matrix-based computations.) Runtimes were further reduced by revising the Simulink model so that all calculations and logical operations were expressed using native Simulink blocks (functions). (It is possible to link a Simulink model to external scripts or code, which can make programming logical and control operations (e.g., IF-THEN) much simpler at the price of increased runtimes.)

Lastly, it should be noted that an attempt was made to implement probabilistic elements by employing randomness in the simulation as specified in the conceptual model (Section 4). Randomness was ignored during the proof of concept stage (Section 6). Randomness was integrated within two general functions of the simulation. First, randomness was added within the function for determining the financial marginality of agents (Equations 5-8 and 5-18), rather than only being a function of income or business size. Second, randomness was integrated in determining whether an agent reaches the next recovery level (e.g., Equation 5-2 and 5-11). The results of implementing randomness are not presented because simulation behavior was not meaningful.

Adding randomness to determine financial marginality did induce variability in agent behavior within the simulation, but did not result in any significant differences in the overall performance of the simulation presented below. This is likely due to the strong influence of the driving variables within the simulation algorithms. One solution may be to modify the role of the financial marginality variable (*MARG*) within the conceptual model and, thus, simulation algorithms. For example, financial marginality may affect the slope of the driving variable, default building restoration (*DBL*).

Several different approaches were taken, unsuccessfully, to implement randomness in determining the likelihood of agents reaching each recovery level. (The general approach was to apply Monte Carlo simulation by comparing the value of a random variable with a threshold value describing the likelihood for moving to the next recovery level.) The inclusion of randomness dramatically increased simulated recovery times, when compared to the simulation without randomness. While the recovery times could be slowed down by modifying the stochastic parameters, this is not desirable because the simulation becomes less sensitive to decision and demographic variables. It is likely that the simulation requires different calibration than without randomness. However, continuing to ignore randomness for this phase of research facilitates comparison of the simulation across the various stages of completed work.

## **7.2 Calibration of Model Parameters**

Because of the significance of the driving variables within the simulation algorithms, it is important to determine reasonable and appropriate values for each. For the test

application (Section 7), slope values were assumed based on expert judgment and insight from the literature. For the application to the Kobe disaster, it was decided to investigate the feasibility of calibrating the driving variables using data describing the recovery process. The most conceptually simple of the driving variables to calibrate were those associated with lifeline recovery (*DCRIT*, *DEL*, *DTRNS*, and *DWAT*) and *DAID*. This is because these are community-level variables that do not vary across neighborhoods or agents.

Calibrating the driving variables for lifeline recovery required answering four questions. The first is whether a mutual aid agreement was in place and used. For the Kobe disaster, mutual aid agreements were largely in place and used (*MUT* = 1). The second question is what the relative restoration priority (*PRTY*) given to each neighborhood. It was assumed that there was equal priority given to all neighborhoods of Kobe. This simplifies the calibration procedures. With different priorities, there would be a different equation and, thus, driving-variable slope-value to calculate for each neighborhood. The third question is what was the amount of damage caused by the earthquake for each lifeline network (including critical facilities). The damage variables and values used for calibration are defined and specified in Table 7-1. The fourth question is what was the time needed to restore service to each lifeline. The estimated restoration time for each is listed in Table 7-1. The restoration time for critical facilities was assumed, otherwise the source is as indicated in Table 7-1. With the above inputs specified the values for each lifeline driving variable was calculated by solving for the slope in each of the four linear equations (Equations 5-25, 5-27, 5-29, 5-31).

**Table 7-1. Damage data used for calibrating recovery simulation.**

Variable	Interpretation	Damage	Restoration Time	Source
<i>EDMG</i>	Percentage of households in Kobe without power immediately after earthquake	100%	1 week	1
<i>WDMG</i>	Percentage of households in Kobe without potable water immediately after earthquake	90%	10 weeks	1,2,3
<i>TDMG</i>	City-wide transport service loss immediately after earthquake	80%	84 weeks	5
<i>CDMG</i>	City-wide loss of critical services immediately after earthquake	50%	1 week	7

**Sources**

- 1 City of Kobe, 1998, "The Great Hanshin-Awaji Earthquake Statistics and Restoration Progress," December.
- 2 City of Kobe, 2000, Kobe Recovery Record, p.10. (in Japanese)
- 3 Chang, S.E. and W.J. Taylor, 1995, "Economic Impact of Lifeline Disruption: Current Models and Preliminary Observations from the Hanshin Earthquake," *Proc. 6<sup>th</sup> U.S.-Japan Workshop on Earthquake Disaster Prevention for Lifeline Systems*, Osaka, Japan. Public Works Research Institute, pp.333-347.
- 4 Chang, S.E. and N. Nojima, "Measuring Post-Disaster Transportation System Performance: The 1995 Kobe Earthquake in Comparative Perspective," *Transportation Research Part A: Policy and Practice*, Vol.35, No.6, pp.475-494.
- 5 National Land Agency, 1995, "Disaster Prevention White Paper," p.16. (in Japanese)
- 6 Takada, S. and J. Ueno, 1995, "Performance of Lifeline Systems During the 1995 Great Hanshin Earthquake," *Proc. 6<sup>th</sup> U.S.-Japan Workshop on Earthquake Disaster Prevention for Lifeline Systems*, Osaka, Japan. Public Works Research Institute, pp.165-184.

The value for the driving variable *DAID* was also determined by solving the slope value for the corresponding linear equation (Equation 5-20). The input required to solve the slope value was the value for *CAP* – the recovery capacity for Kobe. A value of *CAP* = 0 was assumed. (*CAP* is a binary variable within the current simulation implementation.) There is no reliable data for Kobe describing the time required to distribute disaster aid. We assumed similarity with the 1994 Northridge, CA earthquake and used data from the Small Business Association (SBA) on the disbursement of short-term loans. The SBA disbursed all of its aid within 24 weeks. Unfortunately, the value calculated by solving for the slope in the linear equation led to unexpected simulation behavior. The simulation predicted nearly all households would leave the area because of the earthquake. The reason for this behavior is that household debt (from the aid loans) increased too quickly. The algorithm for predicting if a household will leave is highly

dependent on debt (Equation 5-16). As a result, we used the highest slope value possible that would not lead to excessive numbers of households leaving Kobe.

The remaining driving variables were more difficult to calibrate. First, *DINS* is not a slope value, but rather a time when all insurance outlays are made within the simulation (Equation 5-9 and 5-19). Of course, insurance outlays occur over time. Because there was not data readily available on when insurance outlays were made, the value for *DINS* was assumed to be 8 weeks. (The same value used in the test application in Section 7.) Second, no data is readily available for the health recovery of individual households (or coarser analysis units) within Kobe. If data were available, the calibration would be extremely difficult because each household (or rather demographic group) would potentially have a different value for *DHLTH*.

A similar problem exists for the third and fourth driving variables: building restoration (*DBL*) for households and businesses (Equation 5-3 and 5-12). Even so, the approximate time required for building restoration was inferred from damage and new construction data (City of Kobe, 1996). For businesses, restoration time was about 4 years and about 3 years for households. To avoid the complexity of determining a different slope value for each demographic group, a single *DBL* value was determined for both businesses and households. After the other driving variables were calibrated, this was done by trial and error (using the inputs specified in the next section), so that it took about 4 and 3 years, respectively, for building recovery (*BL*) to reach a value greater than 0.9. Unfortunately, due to limitations of the simulation algorithms, not all buildings reached a value greater than 0.9 (after 260 weeks). Therefore, the calibration only considered those agents that did reach  $BL = 0.9$  or greater.

The calibrated values for each of the driving variables are listed in Table 7-2. It will be useful to see how much these values vary across applications, if at all, with future studies using the simulation.



**Table 7-2. Calibrated values for driving variables**

<i>DTRNS</i>	0.0095
<i>DEL</i>	0.85
<i>DWAT</i>	0.016
<i>DCRIT</i>	0.5
<i>DAID</i>	0.008*
<i>DHLTH</i>	0.01**
<i>DBLh</i> (households)	0.003
<i>DBLb</i> (businesses)	0.0042
<i>DINS</i>	8**

\* Originally calculated to be 0.042

\*\* Assumed value

### 7.3 Kobe Scenario

Applying the simulation to the Kobe earthquake required specifying three different groups of variables: decision variables, demographics, and the intensity of the earthquake’s effects. The decision variables are binary (yes/no) and apply to the entire city of Kobe. This constraint is an obvious simplification of reality. For example, some sections of a water pipeline may have been retrofitted, while other sections have not. In specifying the decision variables, we judgmentally determined whether the value was primarily “yes” or primarily “no” based on our knowledge of the event and context. The values determined for each of the nine decision variables are listed in Table 7-3.

**Table 7-3. Decision variable values for Kobe application of model.**

<i>MUT</i>	<i>CAP</i>	<i>PLAN</i>	<i>STH</i>	
Yes	No	No	Yes	
<i>WALT</i>	<i>WMIT</i>	<i>TMIT</i>	<i>EMIT</i>	<i>CMIT</i>
Yes	No	No	No	No

Demographic variables are the attributes of each modeled household and business. For households, the demographic variables are relative income level (i.e., high, medium or low) and whether mitigation measures have been taken to improve the seismic resistance of their residence. For business agents, the demographic variables are relative business size (i.e., small or large), business sector (i.e., export-oriented or local business), and whether mitigation measures have been taken. The simulation requires the specification of the relative number of the population belonging to each unique demographic group (e.g., low income household without mitigation and large export business with mitigation).

The city was divided into four analysis zones, as shown in Figure 7-1. These zones were defined from an aggregation of 170 census statistical blocks (see Chang, 2001). Demographic data for each of the four zones was inferred from various census data publications from Kobe City for businesses and households. The values assigned to each household demographic group are listed in Table 7-4. For businesses, the demographics are listed in Table 7-5.

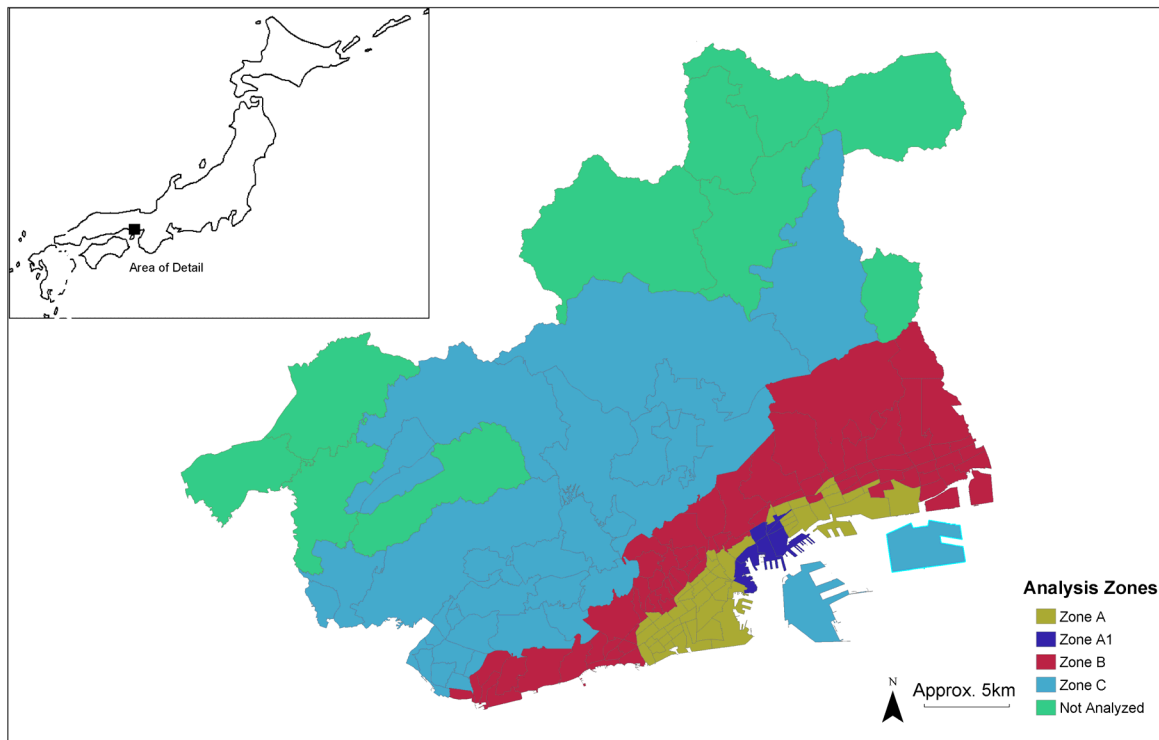

**Figure 7-1. Kobe Analysis Zones**

**Table 7-4. Input household demographics for application to Kobe.**

Zone A1		Bldgs	
		Unmitigated	Mitigated
Income	Low	57%	0%
	Middle	8%	32%
	High	0%	3%

Zone B		Bldgs	
		Unmitigated	Mitigated
Income	Low	17%	0%
	Middle	40%	3%
	High	8%	32%

Zone A		Bldgs	
		Unmitigated	Mitigated
Income	Low	72%	0%
	Middle	13%	10%
	High	0%	5%

Zone C		Bldgs	
		Unmitigated	Mitigated
Income	Low	14%	0%
	Middle	36%	17%
	High	0%	33%

**Table 7-5. Input business demographics for application to Kobe.**

Zone A1		Bldgs	
		Unmitigated	Mitigated
Small	Export	1%	0%
	Local	50%	29%
Large	Export	1%	1%
	Local	3%	15%

Zone B		Bldgs	
		Unmitigated	Mitigated
Small	Export	2%	0%
	Local	47%	39%
Large	Export	0%	3%
	Local	1%	8%

Zone A		Bldgs	
		Unmitigated	Mitigated
Small	Export	10%	0%
	Local	45%	30%
Large	Export	2%	4%
	Local	3%	6%

Zone C		Bldgs	
		Unmitigated	Mitigated
Small	Export	2%	0%
	Local	38%	41%
Large	Export	0%	9%
	Local	0%	10%

The final input required to define the Kobe scenario is the intensity of the effects of the earthquake (*EQ*) for each analysis zone. The analysis units encompass large areas and, thus, a wide range of earthquake intensities that need to be distilled into some representative index. *EQ* has a relative domain between 0 and 1, which facilitates the use of different intensity metrics. For this study, *EQ* was determined by normalizing (dividing by the maximum possible value) a representative JMA intensity value for each zone. The JMA intensity value for each of the four zones was determined using the JMA to peak ground acceleration conversion table of Bardet et al. (1995). Based on the acceleration categories and the general ground motion map in EQE (1995), JMA values were assigned to each of the four zones (Table 7-6). This approach to determining *EQ* is consistent with the spatial resolution and data quality of the analysis. Higher resolution earthquake data could only be used if smaller, more numerous zones were used as the basis of the Kobe recovery simulation.

**Table 7-6. Earthquake intensity values for Kobe recovery simulation**

Zone	PGA	JMA	EQ
A	> 0.5	7	1
A1	>0.5	7	1
B	0.25 - > 0.5	6.5	0.93
C	0.25 - 0.5	6	0.86

## **7.4 Results**

The simulation was performed using the input values described above for a time series of 260 weeks. In each of the 4 neighborhoods, 100 households and 100 businesses were simulated. With the implementation improvements, the simulation had a faster runtime than the smaller test implementation (and shorter time series) at less than one minute using an 850MHz processor. This is encouraging for increasing the detail (e.g., number of neighborhoods) in future simulation applications. The results of the simulation are summarized in Figure 7-2 through Figure 7-7. Based on a relative comparison, the results are less satisfactory overall than the test application (described in Section 6). One obvious unexpected result was the prediction that no households would leave and no businesses would fail. This of course was not the case for the Kobe disaster. Figure 7-2 shows the overall simulated recovery of Kobe including city-wide recovery of households, businesses, buildings, and lifeline network. This figure was constructed by averaging the recovery value for each individual agent (i.e., household or business) across the entire simulation population for each time step. Figure 7-2 shows that not all households and businesses reached a recovery level of one even though no agents failed or left Kobe (and this result does not change by running the simulation for a longer time series). The businesses and household recovery levels plateaued after a time of about 55 and 140 weeks, respectively. Overall lifeline recovery did reach a final value of one after 50 weeks. The general prediction that business and household recovery lags significantly behind lifeline recovery is reasonable. Building restoration only reached an unrealistic recovery level of 0.5 after 260 weeks (5 years).

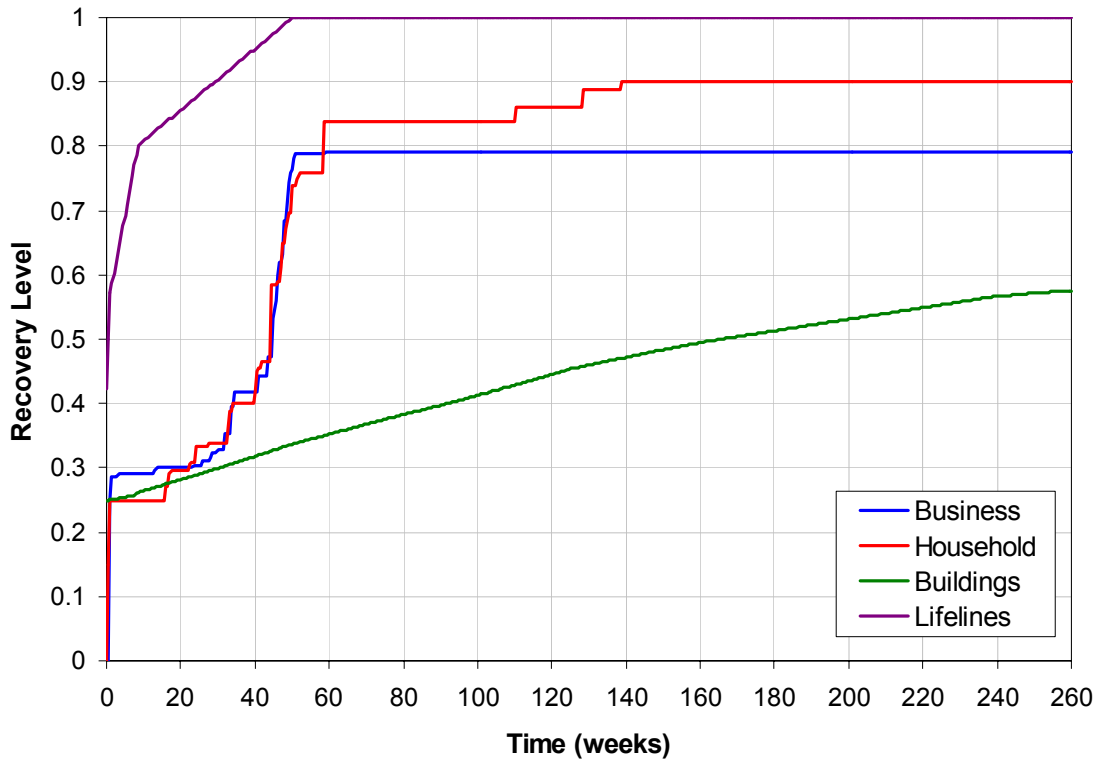

**Figure 7-2. Overall simulated recovery of Kobe using simulation prototype.**

The simulated lifeline restoration for Kobe is broken down further in Figure 7-3. From the figure, the order of recovery for the different lifelines is apparent. The electrical network and critical facilities were restored in a week or less. These were followed by restoration of the water network after about 8 weeks and the transportation network after about 50 weeks. The predicted order is interesting because, within the simulation algorithms (Figure 4-2), the restoration of the electrical and water networks is dependent on the restoration of the transportation network. Even so, the electrical and water networks were fully restored when the transportation network was less than 50% restored. This may indicate an overly strong influence of the driving variable within the lifeline restoration equations.

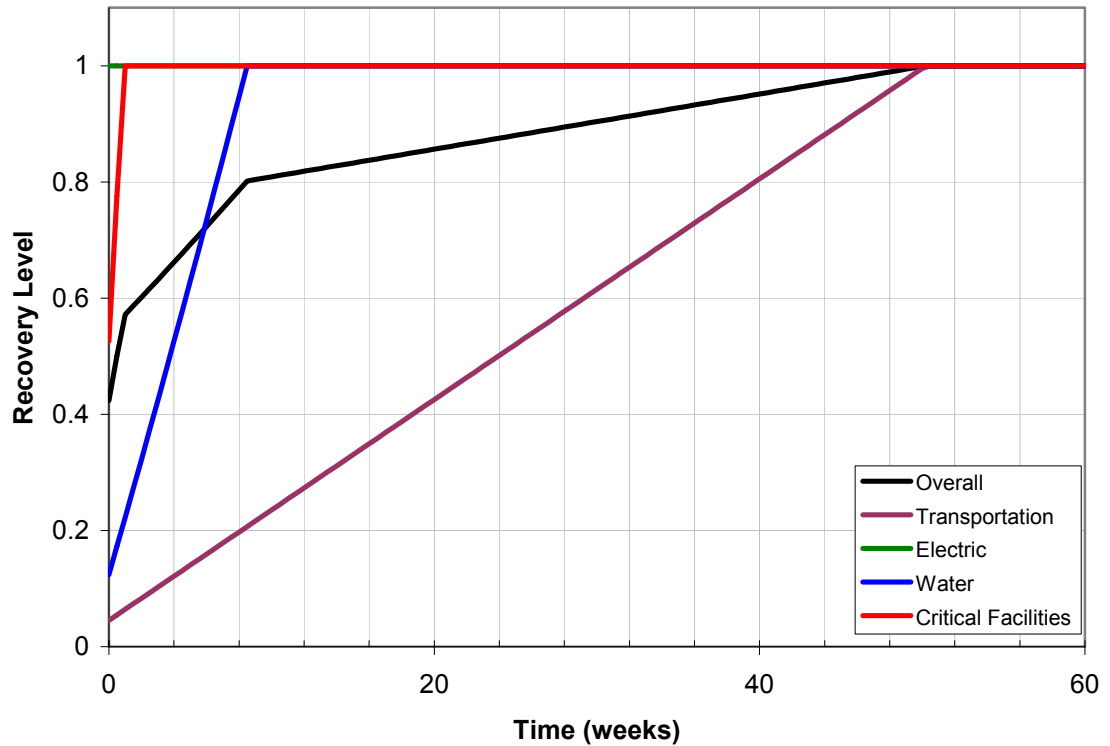

**Figure 7-3. Simulated restoration of individual lifeline networks in Kobe using simulation prototype.**

Figure 7-4 through Figure 7-7 provides information at the zone level for household and business recovery. Looking at the zone-by-zone recovery of households with time (Figure 7-4), the influence of earthquake intensity and demographics is obvious. The zones that recovered the slowest and to the lowest final levels of recovery are Zones A and A1, which both had a JMA intensity of 7. The zone that recovered to quickest and to the highest level of recovery was Zone C, which experienced the lowest earthquake intensity. The difference between Zones A1 and A, which were both assigned a JMA of 7, is explained by the demographics. Zone A has 15% more low income households and 20% more household in old or unretrofitted buildings.

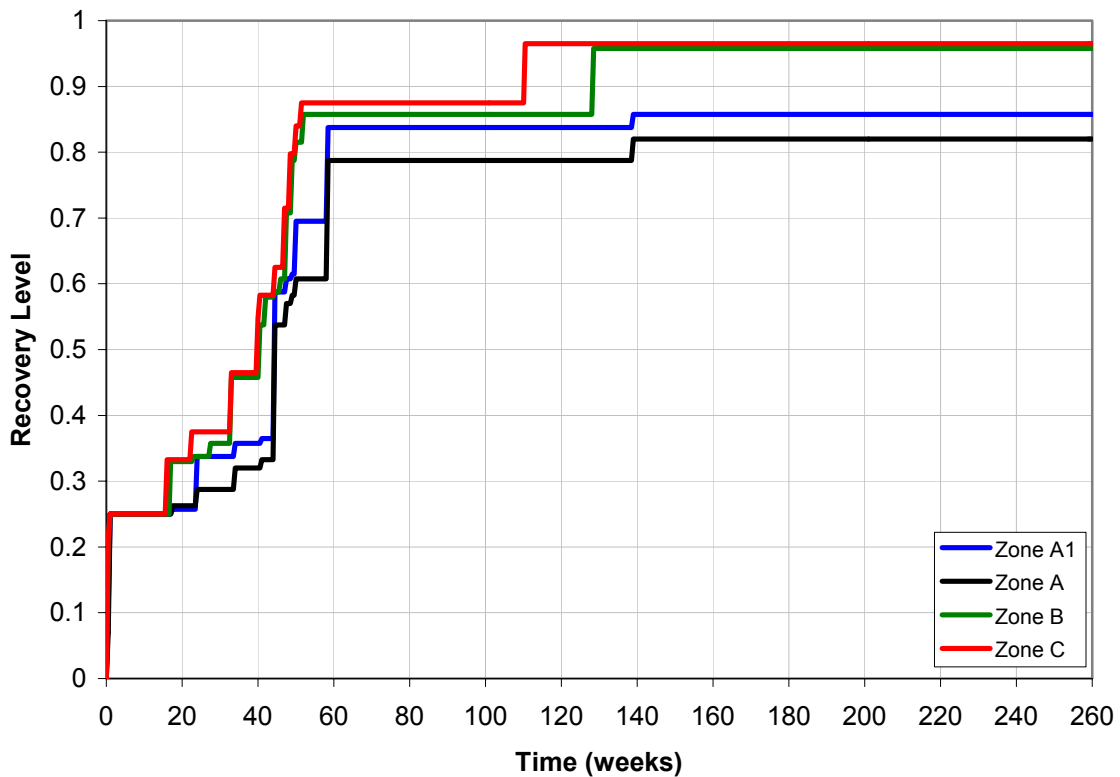

**Figure 7-4. Simulated recovery of households by zone for Kobe using simulation prototype.**

Figure 7-5 presents the recovery levels of each zone at selected times to illustrate the operation and information detail of the simulation. Looking at the bar chart for week 104, the same order of recovery seen in Figure 7-4 is observed. However, it is now apparent that the majority of households did not reach a recovery level of 1. For those households that did reach the final recovery level, this occurred within 52 weeks of the simulated disaster.

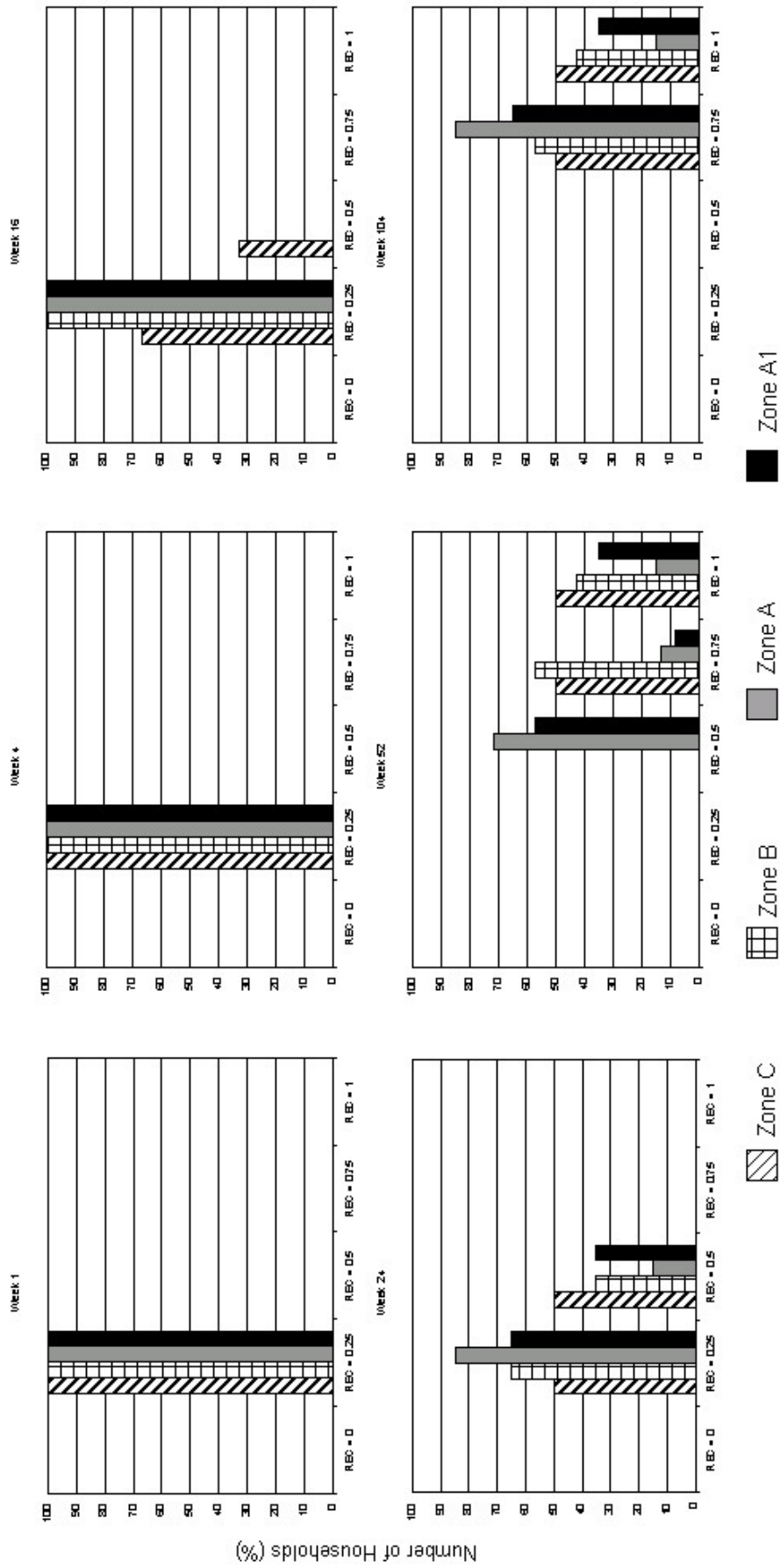
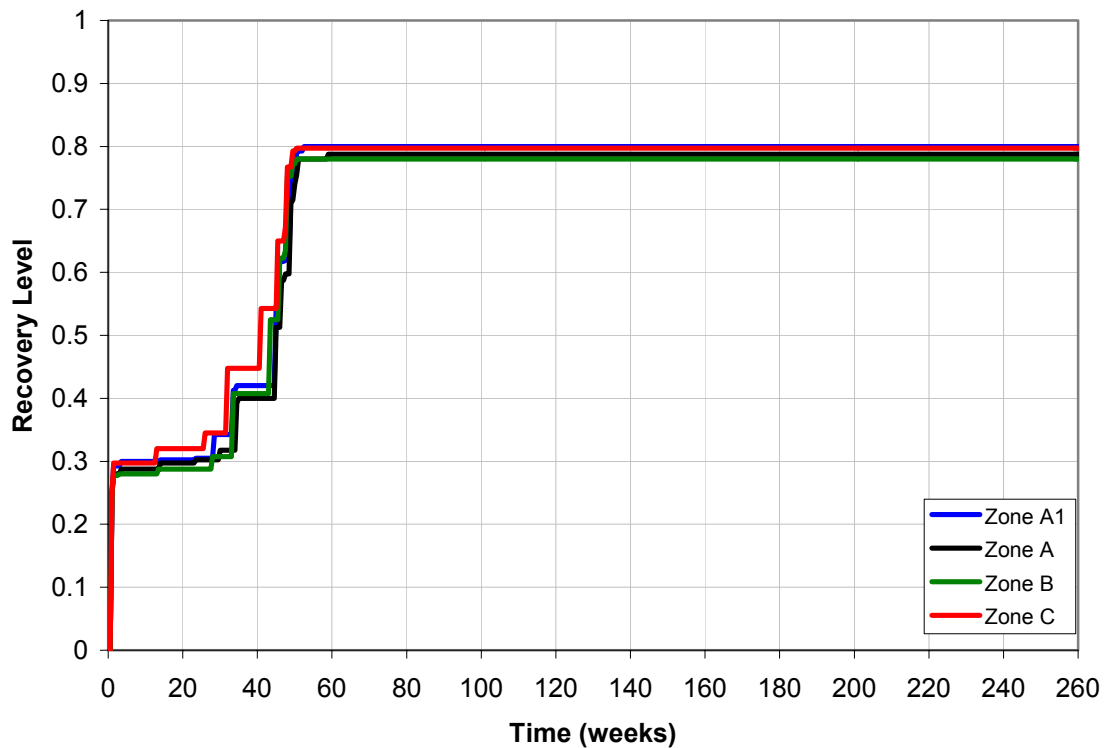

Figure 7-5. Simulated recovery of households by zone for relative recovery levels.



The recovery predictions for Kobe businesses (Figure 7-6 and Figure 7-7) are less reasonable. There is very little difference between predicted recovery for each zone. A large majority of businesses was not predicted to reach complete recovery. Looking at Table 7-5, it appears the businesses that did reach a recovery level of 1 were large businesses (regardless of sector or building mitigation). It is possible that there is not a strong enough dependency on earthquake intensity within the simulation algorithms for business recovery. Conversely, observing that the demographics are all fairly similar, it is equally possible that the business size has too much influence within the simulation algorithms.



**Figure 7-6. Simulated recovery of businesses by zone for Kobe using simulation prototype.**

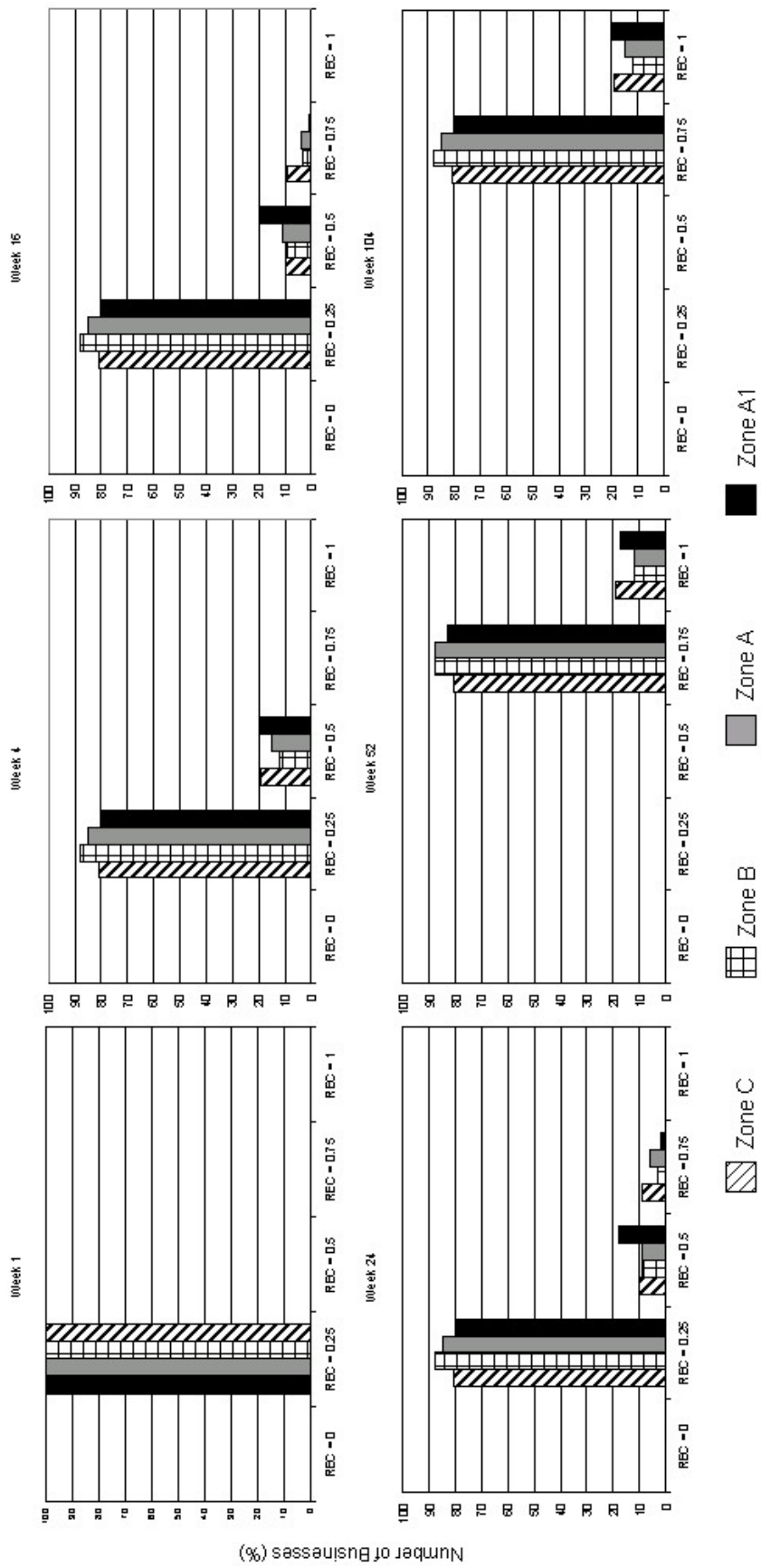
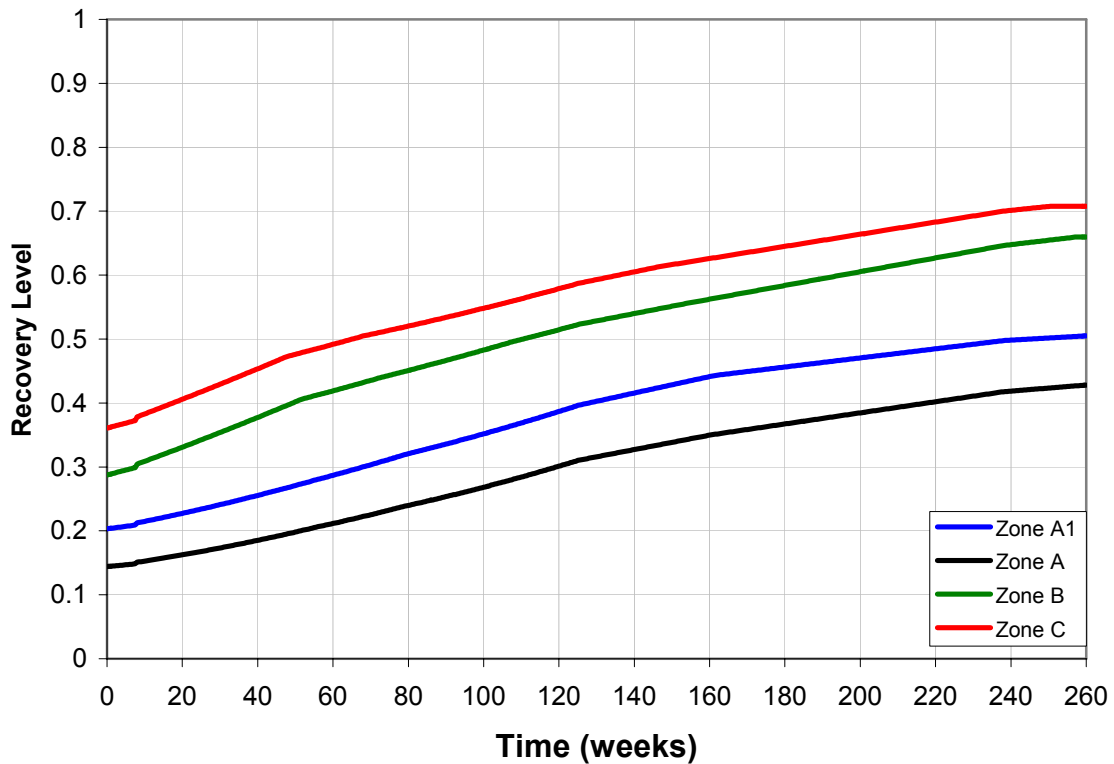

Figure 7-7. Simulated recovery of businesses by zone for relative recovery levels.

Figure 7-8 shows a similar order for building restoration as Figure 7-4 does for household recovery. Zone C recovered the most in the same time as the other zones, with Zone A recovering the least. With the driving variable ( $BL$ ) being equal for all agents, this order is dictated by the degree of initial damage ( $DMG$ ), which is in turn controlled by earthquake intensity, financial marginality and mitigation measures (Equations 5-5 and 5-14). The simulation predicted that none of the zones would reach a restoration level greater than 65% after 260 weeks, which is relatively unreasonable. The slow simulated restoration times suggests that a more appropriate means of determining  $DBL$  is needed, along with making building restoration more sensitive to agent attributes.



**Figure 7-8. Simulated restoration of buildings by zone for Kobe using simulation prototype.**



## Section 8

### Prototype Application: Sensitivity Analysis

A great deal of insight into the simulation framework and implementation was gained from the test (Section 6) and prototype applications (Section 7). However, because of the large number of simulation variables (especially for implementations with several neighborhoods, businesses, and households) and the numerous corresponding relationships, it is important to systematically investigate the behavior of the simulation. However, for the same reason a complete sensitivity analysis of the Kobe disaster simulation would be extremely time-consuming and the results would be difficult to effectively interpret and convey. Thus, a sensitivity analysis approach was decided on that would give a good overview of the simulation behavior and facilitate the evaluation of several expectations of the simulation model.

#### 8.1 Sensitivity Analysis Approach

For the sensitivity analysis, decision and demographic variables were analyzed separately; though, the basic approach was the same. The simulation of Kobe described in Section 7 formed the basis of comparison for the sensitivity analysis. To reduce the scope of the sensitivity analysis, no effort was made to directly analyze the entire range of potential states (combination of variable values) of the simulation. Instead, the effect of changing each variable was analyzed independently, while holding the other variables constant.

To characterize the effect of the demographic variables on the simulation behavior and output, the simulation was configured and run twice for each of the 8 demographic variables. Configuring the simulation consisted of modifying the baseline simulation (applied to the Kobe disaster) so that each agent had the same value for the particular variable under analysis, while all other variable values were left as described in Section 7.3. The simulation then was run once for the maximum and minimum value that the particular variable could take one. Thus, for example, to analyze the demographic variable *INC* for households, the simulation was run once with all households assigned a relative income of “low” (a value of zero), with all other input variables retaining the

baseline values, and again with all households being assigned a relative income of “high” (a value of 1).

To analyze the decision variables, the simulation was first run, using the Kobe demographics, once with all of the decision variables set to zero or “no” (i.e., zero capacity, no mutual aid agreement, no plan, etc.). (This is referred to later as the pessimistic baseline.) The simulation was then run nine more times to look at the effect changing each decision variable to one or “yes”, with the other decision variables being set to zero. The opposite approach was also taken, where all variables were set to one (optimistic baseline) and then the simulation run for each variable set to zero.

Finally, to assist in interpreting the results of the sensitivity analysis, several expectations for behavior of the simulation were identified and listed. The expectations are listed in Table 8-1.

**Table 8-1. Expectations of simulation behavior for sensitivity analysis**

Demographic Variables	<ol style="list-style-type: none"> <li>1. *A community with all new or retrofitted buildings (i.e., earthquake resistant) should recover more quickly than a community with all old buildings.</li> <li>2. *A community with all high income households should recover more quickly than a community with all low income households.</li> <li>3. *A community with all large businesses should recover more quickly than a community with all small businesses.</li> <li>4. *A community with all export-oriented businesses should recover more quickly than a community with all local-oriented businesses.</li> </ol>
Decision variables	<ol style="list-style-type: none"> <li>5. All lifeline mitigations should hasten recovery times.</li> <li>6. Mitigating transportation should hasten recovery more than mitigating other lifelines.</li> <li>7. All planning and response measures should hasten recovery times.</li> <li>8. Agents should be less likely to fail or leave as more mitigation and planning measures are taken.</li> </ol>

\*=assuming all else equal

## 8.2 Results

The results of the sensitivity analysis are summarized in Table 8-2 through Table 8-7. Table 8-2 and Table 8-3 describe the influence of demographic variables on household

and business recovery, respectively. Similarly, Table 8-4 through Table 8-7 describe the influence of decision variables on household and business recovery. All of the tables have four rows corresponding to one of the four analysis zones for Kobe. The columns of the tables correspond with the particular variable being analyzed, with the first column of values serving as the basis of comparison. Table 8-2 and Table 8-3 each have a column labeled “Baseline”, which corresponds to the demographic data estimated for Kobe as described in Section 7.3. Table 8-4 and Table 8-5 each have a column labeled “None”, which corresponds to a simulation run with no mitigation measures taken. Similarly, Table 8-6 and Table 8-7 each have a column labeled “All”, which corresponds to a simulation run with all mitigation measure taken. The values listed in all of the tables are the percentage of agents (households or businesses) that have reached a recovery level of 1 (complete recovery) after 2 years. If no agents reached a recovery level of 1 or the information is ambiguous, the percentage of agents reaching a recovery level of 0.75 is given in parentheses.

### 8.2.1 Demographic Variables

**Table 8-2. Summary of sensitivity analysis of demographic variables for households.**

2 years	Baseline	Old	New	Small	Large	Local	Export	Low	High
Zone A1	35	3	43	35	100	35	35	0 (100)	100
Zone A	15	5	28	15	100	15	15	0 (100)	100
Zone B	43	40	83	43	100	43	43	0 (100)	100
Zone C	50	33	86	50	100	50	50	0 (100)	100

**Table 8-3. Summary of sensitivity analysis of demographic variables for businesses.**

2 years	Baseline	Old	New	Small	Large	Local	Export	Low	High
Zone A1	20	20	20	0 (100)	100	20	20	20	99
Zone A	15	15	15	0 (100)	100	15	15	15	90
Zone B	12	12	12	0 (100)	100	12	12	12	98
Zone C	19	19	19	0 (100)	100	19	19	19	98

The results of the sensitivity analysis can be used to evaluate the expectations listed in Table 5-1. Expectations 1 through 4 relate to the analysis of the demographic variables (Table 8-2 and Table 8-3). For households, expectation 1 is met, with the scenario having all new buildings leading to more recovered households than a community with

all old buildings. Further, the old and new scenarios compare well with the baseline demographics for Kobe, which falls in between these extreme scenarios. Unfortunately, for business recovery, the simulation does not produce expected results. The modeled business recovery for the three scenarios (baseline, old and new) is the same. Considering expectation 2, the simulation clearly distinguishes between the low- and high-income scenarios, for both household and business recovery. For business recovery however, there is no simulated difference between the low-income scenario (all households have low income) and the baseline demographics (mixed income). For expectation 3, the results are similar, with an obvious distinction between the small- and large-business scenarios. In this case, however, there is no distinction between the small-business scenario and the baseline demographics for household recovery. Lastly, the simulation did not perform well with respect to expectation 4. No difference was predicted by the simulation between the local- and export business scenarios and the baseline demographics. The general reason that the simulation is more sensitive to the variables *INC* and *SIZE* is the relative number of times these two variables occur in the simulation equations. The other demographic variables, conversely, appear in only one respective equation.

It should be noted that the simulation predicted that no households would leave or businesses would fail for any of the demographic variable scenarios analyzed. This is somewhat surprising considering cases such as all households with low income or all small businesses. This suggests that, within the simulation, the context or environment is more influential than demographics in determining whether agents fail or leave.

### 8.2.2 Decision Variables

**Table 8-4. Summary of sensitivity analysis of decision variables for households; pessimistic baseline.**

2 years	None	CAP	MUT	PLAN	STH	TMIT	EMIT	CMIT	WMIT	WALT
Zone A1	0 (35)	0 (43)	35	3	0 (43)	35	0 (35)	0 (35)	0 (35)	0 (35)
Zone A	0 (15)	0 (28)	15	5	0 (28)	15	0 (15)	0 (15)	0 (15)	0 (15)
Zone B	0 (43)	0 (83)	43	43	0 (83)	43	0 (43)	0 (43)	0 (43)	0 (43)
Zone C	0 (50)	0 (86)	50	50	0 (86)	50	0 (50)	0 (50)	0 (50)	0 (50)



**Table 8-5. Summary of sensitivity analysis of decision variables for businesses; pessimistic baseline.**

2 years	None	CAP	MUT	PLAN	STH	TMIT	EMIT	CMIT	WMIT	WALT
Zone A1	0 (20)	2	17	2	2	17	0 (20)	0 (20)	0 (20)	0 (20)
Zone A	0 (15)	6	6	6	6	6	0 (15)	0 (15)	0 (15)	0 (15)
Zone B	0 (12)	3	12	3	3	12	0 (12)	0 (12)	0 (12)	0 (12)
Zone C	0 (19)	9	19	9	9	19	0 (19)	0 (19)	0 (19)	0 (19)

**Table 8-6. Summary of sensitivity analysis of decision variables for households; optimistic baseline.**

2 years	All	CAP	MUT	PLAN	STH	TMIT	EMIT	CMIT	WMIT	WALT
Zone A1	43 (57)	43 (57)	43 (57)	43 (57)	43 (0)	35	43 (57)	43 (57)	43 (57)	43 (57)
Zone A	28 (72)	28 (72)	28 (72)	28 (72)	28 (0)	15	28 (72)	28 (72)	28 (72)	28 (72)
Zone B	83 (17)	83 (17)	83 (17)	83 (17)	83 (0)	43	83 (17)	83 (17)	83 (17)	83 (17)
Zone C	86 (14)	86 (14)	86 (14)	86 (14)	86 (14)	50	86 (14)	86 (14)	86 (14)	86 (14)

**Table 8-7. Summary of sensitivity analysis of decision variables for businesses; optimistic baseline.**

2 years	All	CAP	MUT	PLAN	STH	TMIT	EMIT	CMIT	WMIT	WALT
Zone A1	20 (80)	20 (80)	20 (80)	20 (80)	20 (80)	20 (28)	20 (80)	20 (80)	20 (80)	20 (80)
Zone A	15 (85)	15 (85)	15 (85)	15 (85)	15 (85)	15 (30)	15 (85)	15 (85)	15 (85)	15 (85)
Zone B	12 (88)	12 (88)	12 (88)	12 (88)	12 (88)	12 (88)	12 (86)	12 (88)	12 (88)	12 (88)
Zone C	18 (81)	18 (81)	18 (81)	18 (81)	18 (81)	18 (81)	18 (81)	18 (81)	18 (81)	18 (81)

Expectations 5 through 8 relate to the sensitivity analysis of decision variables. Looking at Table 8-4 and Table 8-5, expectation 5 was not met for both households and businesses according to the sensitivity analysis. Only mitigation of the transportation network (*TMIT*) led to modeled recovery that is better than if no measures were taken at all. This observation, however, does meet expectation 6 that transportation mitigation have greater influence than other lifeline mitigation alternatives. The simulation is likely more sensitive to *TMIT* because of the relative number of times it appears in the conceptual model. Expectation 7 was met because every planning and response measure (*CAP*, *MUT*, *PLAN*, and *STH*) resulted in better recovery than if no measures were taken. Of these variables, having and using a mutual aid agreement had the most effect (equal to mitigation measure for the transportation network).

Table 8-6 and Table 8-7 show the positive influence of the decision variables on recovery. Between the case of no measures taken and all measures taken, the recovery of all four zones significantly improved. The sensitivity analysis results shows that it requires several measures to be taken to see the most benefit. With this information, expectations 5 through 7 can be further evaluated. For household recovery, it is now apparent that *STH* has a strong influence on simulated recovery. For both agents, the importance of *TMIT* is further supported.

Expectation 8 corresponds to fewer businesses failing or households leaving as more measures are taken. For businesses, there are a large number of failures for the pessimistic baseline (when no measures are taken) and the related scenarios. If all measures (optimistic baseline) are taken, no businesses fail. This is true for the related scenarios, except for if transportation mitigation measures (*TMIT*) are not taken which causes a large number of businesses fail. For households, when no measures are taken, several households leave. The same is true for all related scenarios except when short-term housing is employed (*STH*), which results in no households leaving. When all measures are taken, the simulation predicts that no households will leave. Again *STH*, has a strong influence and several households leave if short-term housing is not relied on.

## Section 9

### Synthesis and Conclusions

The initial research and prototype application described in this report illustrate how investing in pre-disaster mitigation of lifelines and reduction of social vulnerability can help reduce losses to the community and hasten recovery, as well as diminish the socio-economic and spatial disparities in disaster impacts. Clearly, a range of preparedness, mitigation, and planning scenarios could be identified and evaluated with the descriptive power of a robust conceptual model and the predictive power of the computer simulation. Completing development of these tools is important to afford useful, multi-faceted understanding of the implications and benefits of decisions regarding risk reduction and disaster recovery.

With the complexity of disaster recovery and scope of the conceptual model and computer simulation, many shortcomings, limitations, and issues were expected to arise out of the first four stages of development. The objective of the work to date was not to develop an accurate predictive model. To date, the research has focused on what has been done as part of other studies and scoping what is feasible. A broad and concerted research program is required to make significant progress in characterizing the complexity of socio-economic recovery and, in turn, constructing large computer simulations of community recovery from disasters. At this point, however, the simulation model does provide a useful rhetorical and educational tool for illustrating concepts of community recovery. Its development has also identified data collection and research needs for developing more refined recovery models. It is important to enumerate the insights obtained in the development and application of the recovery model so far and to formalize them as concrete recommendations for designing the next phase of research and development.

## 9.1 Emergent Issues and Recommendations

### 9.1.1 Conceptual Limitations

The conceptual framework abstracted the complex process of urban disaster recovery into a structure that captures the essence of the process. In the course of this research, several limitations became apparent that relate to this abstraction. Further research is needed to address these limitations.

- *Defining and measuring recovery* – First and foremost, the concept of recovery was implemented here as a series of levels, culminating with a “completely recovered” stage that represents a return to pre-disaster conditions. This simplification led to several problems that pertain to definition and measurement: (1) it is inconsistent with a concept of recovery that compares “with” and “without” disaster timepaths, as opposed to “before” and “after” disaster (see Figure 5-1)<sup>2</sup>; (2) it does not address how to measure recovery in real-world terms, for example, the correspondence between recovery stages and data that are likely to be available after a disaster; and (3) it does not consider how definitions of recovery may need to differ according to scale of analysis (e.g., that recovery at the community level may be different than simply the average of recovery of agents in the community). Generally speaking, this approach makes it very difficult to validate the model with data from actual disasters.
- *Binary decision variables* – All of the decision variables in the model are, for the sake of simplicity, either “on” or “off”. In actuality, the concepts being modeled are far from binary. Mitigation measures may vary by degree (e.g., whether a plan is a good one), spatial variability (water pipeline may be retrofitted in one neighborhood but not another), and whether or not actually employed (e.g., a recovery plan or mutual aid agreement).

---

<sup>2</sup> However, to implement a “without”-earthquake baseline would require the model to include economic and other forecasting capability, which introduce additional complexities and uncertainties.

- *Agent attributes* – For illustrative purposes, only a few agent attributes were considered with only 2 or 3 classes for each attribute (e.g., export-oriented v. locally-oriented businesses). This simplification did not allow finer distinctions within the categories (e.g., specific economic sectors). It also did not consider other relevant attributes such as the entrepreneurial capabilities of business owners or managers, or educational attainment levels of households. The simplification of agent attributes led to results that were more clustered and less varied than would be observed in an actual disaster.
- *Financial marginality variable* – While the literature indicates the importance of pre-disaster financial marginality in influencing recovery, it is not clear on the mechanisms through which this influence is exerted. For example, it is unclear whether residential building restoration for a household is affected by financial marginality only through the influence of initial building damage (Equation 5-12), or whether this influence also modifies the speed of reconstruction in other ways (see also “influence of variables,” below). This is further complicated by the difficulty of disentangling the effects of low income from those of financial marginality (see also “correlation between variables,” below).
- *Migration* – In the current framework and model, businesses can either survive or fail, and households can either stay or leave the region. There are no provisions for internal migration within the region from one neighborhood to another. Moreover, there are no provisions for new businesses or households to be established or in-migrate. This structure creates a situation whereby neighborhoods and the community cannot grow beyond their pre-disaster states, i.e., which allows population losses but disallows redistributive effects or gains.
- *Model structure* – The conceptual framework and model are derived using Object Modeling Technique, empirical literature, and experience. This has both advantages and disadvantages. For example, it enables the appropriation of insights from a broad, varied, and largely qualitative literature on disaster recovery. It allows the recovery process to be captured in its essence and with parsimony. It enables model design choices that reduce the data demands

associated with model implementation. These advantages are very important in prototyping. However, in comparison with more formal model structures (e.g., computable general equilibrium models or models based on random utility theory), it is disadvantaged in lacking theoretical grounding in the operations and driving mechanisms of the urban economic system. The feasibility of incorporating more formal economic models – which by themselves cannot capture the essential aspects of disaster recovery – as an element of the recovery model should be explored in future research.

### 9.1.2 Simulation Algorithm Issues

A number of implementation issues related to simulation algorithms were also discovered in the course of this research:

- *Influence of variables* – The relative influence of a specific variable turns out to be dictated by the number of times it appears in the simulation equations. This makes it difficult to adjust the model’s sensitivity or to configure the simulation to match unique applications.
- *Randomness or uncertainty* – Randomness needs to be designed into the algorithms in a more reliable fashion. It may not be possible in practice to develop or calibrate the simulation as versions with and without randomness.
- *Driving variables* – The relative sensitivity of intermediate model variables is strongly related to the values to which slopes of the default restoration functions are set. For example, if a slope variable is quite small, then the intermediate variable itself will be very significant in the performance of the model. Changing a related decision variable – for example, from 0 to 1 – can increase the speed of restoration. In some cases, the default slope values may have too much influence. This is because the corresponding intermediate variable shows up in many equations. In this case, the model is not sufficiently sensitive to changes in the decision variable value. For example, if *DAID* is set too high, vulnerable households fail almost as a rule, regardless of the values that other variables are set to. This is because they accrue too much debt too quickly. This

contradicts the notion that more rapid disbursement of disaster assistance is preferable to slower disbursement.

- *Flatlining* – Related to the issue of driving variables is the finding that the dynamics of the model are largely driven by the default restoration functions (e.g., transportation restoration), although these are modified by various demographic and policy variables. An unanticipated outcome is that once the restoration functions have reached their maximal values (e.g., once transportation is fully restored), there are no remaining forces that drive the recovery process. At this point, recovery “flatlines” or plateaus. Additional time does not then produce any change in the results. This can lead to having many agents that never reach  $REC=1$ .
- *Calibration of driving variables* - The interactions between driving variables or default slopes is very influential, but also very difficult to understand and control. The calibration of an individual default slope value is problematic because, in interaction with other slope values, the attendant gross model behavior may not be acceptable. This issue is discussed further below.
- *Correlation between variables* – Many variables in the model are closely correlated empirically. In many instances, these correlations are implemented in the equations as if they had causative effect (e.g., marginality *MARG* as a variable that helps determine building damage *DMG*). This may lead to highly correlated variables having disproportionate influence on recovery outcomes.

### **9.1.3 Challenges in Calibration**

- *Calibrating the driving variables* – For the most part, driving variables are specified as “default” restoration timepaths that are speeded up or slowed down by a variety of demographic, policy, or other variables. While conceptually appealing, this creates problems for calibration. Many of the driving variables cannot be decoupled. Technically, there would be different restoration curves for every agent or at least agent demographic group. Those driving variables that can be decoupled may be conceptually ambiguous. That is, it is difficult to

collect data that corresponds to that “default” situation or even know what data to collect.

- *Alternative approaches to calibration* - In this work, we had primarily sought to calibrate individual restoration timepaths and validate aggregate recovery outcomes, to the extent possible, with available empirical data. However, the complexity of the model suggests that newer, soft computing techniques for calibrating or training the model may be promising. Artificial neural networks (or genetic algorithms) can be used to estimate parameters through positive feedback learning.

#### **9.1.4 Data Requirements**

Input data processing was fairly effortless, but only because of simplifications and assumptions. Higher resolution data on demographics is required to both configure and evaluate the simulation. Associated challenges are:

- *Selecting appropriate spatial units* – Spatial units in the Kobe simulation case were chosen from an economic and social standpoint. The 4-zone classification was based on historic patterns of urban development (i.e., older areas to newer areas). This made sense from the standpoint of the vintage and associated vulnerability of the building stock, as well as from considerations of population and business patterns across the urban space. However, this selection was not optimal from the standpoint of other data considerations: (1) only limited data was available because the zones did not correspond to political units, i.e., city wards, on which basis much more data is collected; and (2) earthquake intensity had to be treated coarsely, neglecting spatial variations in ground shaking within the zones.
- *Timeframes of available data* – Very little of the input data required by the model is routinely collected in time series form after a disaster. Household and business level data on income, building residence, and relative recovery after specific time-periods would greatly improve this simulation and earthquake recovery



knowledge in general. Without this level of data, simplifications and assumption were necessary.

### 9.1.5 Interpreting Simulation Output

One of the strengths of the framework and model is that a multi-faceted series of results are produced that illustrate the complexity of the recovery process. This does, however, entail a number of difficulties in interpreting the simulation outputs:

- *Comparing scenarios* - It is difficult to compare one scenario to another because of the ambiguity in meaning for *REC* and its various levels. Two scenarios may have the same average *REC* level, but one of these may have half of the agents at  $REC = 1$  and half at  $REC = 0.25$ , while another scenario has the same average value but all agents are above  $REC = 0.25$  (i.e., a more equitable recovery). For this reason as well, it is difficult to say when “recovery” has occurred unless it is defined unambiguously as average  $REC = 1$ . Practically, this problem presents issues of how to communicate or present the model results in some meaningful (or at least concise) way.
- *Summarizing recovery* – On a related note, using an “average” recovery for neighborhoods and community was not straightforward. If some agents do not completely recovery (or fail or leave), then the average recovery level will not reach a level of 1, indicating pre-earthquake conditions. Further, information is lost because it is not clear which agents have recovered at a given time and which have not. Moreover, a single index of recovery is not representative of the numerous aspects of recovery. Presentation of results is then critical because the wealth of output is overwhelming and often difficult to discern. Computer-based visualization may facilitate interpretation of results. Simulation results will be easier to interpret for specific questions or within well-defined uses.
- *Measuring recovery and other variables* – As noted earlier, model outputs (e.g., *REC*) were not conceptualized to match available data and real world metrics. This creates problems in validating and interpreting model outputs. In further

work, outputs could be represented in such terms as population numbers, gross city product, number of open businesses, or jobs.

## **9.2 Further Research**

### **9.2.1 Stakeholder Evaluation of Prototype**

Enlisting potential stakeholders will help to further evaluate usability of the simulation. Stakeholders may identify missing variables (e.g., important decision alternatives). Otherwise, they may help to recast the conceptual basis of variables and how variables are related. Stakeholders will provide input on how to present model results and later issues such as how it is delivered (e.g., what features of GIS and what level of user interface). An idea for how the simulation might be appropriated and used could be obtained.

### **9.2.2 Improve Conceptual Model and Model Algorithms**

Simulation algorithms can be improved by incorporating existing equations and models, or by using empirical or model-generated data. With the object-oriented framework, it would be simple to change each of the functions without requiring a significant amount of modification to the rest of the simulation algorithms. Candidates for this treatment include all damage estimation and earthquake intensity functions. This work should focus on identifying and operationalizing relationships of recovery and creating a recovery decision-support system.

The implementation of the driving variables needs to be rethought to eliminate the problem with the model flat-lining and conceptual mismatch for calibration. This also may be solved by finding combinations of values for the driving variables that seem to resolve this behavior. The result of the empirical calibration described in this report showed that the driving variables might not have a concrete analogue.

The specific means for determining the recovery level needs to be rethought to be more explicitly probabilistic. This will address the difficult experienced in implementing randomness in the simulation. The recovery levels should also be better defined conceptually.

The simulation should be improved to model migration within the community (i.e., from neighborhood to neighborhood). The decision to migrate can be based on variables such as relative recovery levels of neighborhoods, location, access to financial resources, building damage, and reconstruction status.

Various variables may be modified, depending on the stakeholder evaluation. For example, construction may be added as a third business sector (in addition to local- and export-oriented businesses). Lifeline mitigation can be done by neighborhoods. Many variables, such *INC*, *SIZE*, and *CAP*, are actually continuous variables within the simulation. However, the conceptual model needs to be strengthened to facilitate specifying values for these variables.

Fuzzy systems may be explored as a possible methodology for implementing the conceptual model. The methodology is appealing because it easily integrates variables of different scales and units. Qualitative information can be used both in specifying the model and as input data. The qualitative information is logically incorporated with common numerical data (e.g., consensus data on incomes). Fuzzy systems has well defined means for modifying the relative influence of a variable or model component. Outputs reflect the precision and uncertainty in both the input data and particular model algorithms used (e.g., results might be obtained with missing data).

The model algorithms could also be improved with data from a broader suite of disasters and additional test examples beyond the hypothetical city and the Kobe disaster.

### **9.2.3 Integrate with GIS**

To meet the goal of migrating the simulation into a spatial decision support system, it may be integrated with ESRI's ArcGIS. This would require a large effort because of the many different input data types. However, it would facilitate using actual and model-based data for inputs (e.g., earthquake intensity, lifeline restoration, and building inventories), modeling household migration, and visualization of results (and contextual information). ArcGIS is well suited because of the wealth of customization possibilities using popular programming tools. As part of this phase, an intuitive graphical user interface may be developed. Integration with a GIS system could also allow other

improvements, such as dynamically specifying the number of neighborhoods based on spatial data, or querying of demographic groups across neighborhoods.

#### **9.2.4 User Guide**

A user guide should be developed. This would not necessarily be a document explaining how to run the simulation. Rather, it would be a set of guidelines describing when to appropriate the simulation, how to gather input data, and how to situate the simulation in various management and planning situations. Hypothetical and actual scenarios and case studies will be described that illustrate ways the simulation can be used to realize aspects of risk reduction. The contents of this guide could be based on the stakeholder evaluations and future applications involving either the prototype or mature simulation.

## Section 10

### References

- Alesch, D. J. and J. N. Holly (1998). "Small Business Failure, Survival, and Recovery: Lessons from the January 1994 Northridge Earthquake." *NEHRP Conference and Workshop on Research on the Northridge, California Earthquake of January 17, 1994*. Richmond, CA: CUREe.
- Bardet, J. P., F. Oka, M. Sugito, and A. Yashima, 1995, "The Great Hanshin Earthquake Disaster, The 1995 South Hyogo Prefecture Earthquake, Preliminary Investigation Report," Report, Civil Engineering Department, University of Southern California, Los Angeles, California, USA, and Civil Engineering Department, Gifu University, Gifu, Japan.
- Berke, P. R., J. Kartez, and D. Wenger. (1993). "Recovery after Disaster: Achieving Sustainable Development, Mitigation and Equity." *Disasters* **17**(2): 93-109.
- Blaikie, P., T. Cannon, I. Davis and B. Wisner (1994). *At Risk: Natural Hazards, People's Vulnerability, and Disasters*. New York: Routledge.
- Bolin, R. (1993). *Household and Community Recovery After Earthquakes*. Boulder, Colorado, Institute of Behavioral Science, University of Colorado.
- Bolin, R. and P. Bolton (1986). *Race, Religion, and Ethnicity in Disaster Recovery*. Boulder, CO, Institute of Behavioral Science, University of Colorado.
- Bolin, R. and L. Stanford (1991). "Shelter, Housing and Recovery: A Comparison of U.S. Disasters." *Disasters* **15**(1): 24-34.
- Brookshire, D. S., S. E. Chang, H. Cochrane, R. A. Olson, A. Rose and J. Steenson (1997). "Direct and Indirect Economic Losses from Earthquake Damage." *Earthquake Spectra* **13**(4): 683-701.
- Chang, S.E. (1996) "Economic Impact of Lifeline Disruption in the January 17, 1995 Hanshin-Awaji Earthquake," *Proc. 11th World Conference on Earthquake Engineering*, Acapulco, Mexico.
- Chang, S. E. (2001). "Structural Change in Urban Economies: Recovery and Long-Term Impacts in the 1995 Kobe Earthquake," *The Kokumin Keizai Zasshi (Journal of Economics & Business Administration)*, **183**(1): 47-66.
- Chang, S.E. and N. Nojima. (2001) "Measuring Post-Disaster Transportation System Performance: The 1995 Kobe Earthquake in Comparative Perspective," *Transportation Research Part A: Policy and Practice*, Vol.35, No.6, pp.475-494.
- Chang, S.E., W.D. Svekla, and M.Shinozuka. (2002) "Linking Infrastructure and Urban Economy: Simulation of Water Disruption Impacts in Earthquakes," *Environment and Planning B*, Vol.29, No.2, pp.281-301.

- Chang, S.E. and W.J. Taylor. (1995) "Economic Impact of Lifeline Disruption: Current Models and Preliminary Observations from the Hanshin Earthquake," *Proc. 6<sup>th</sup> U.S.-Japan Workshop on Earthquake Disaster Prevention for Lifeline Systems*, Osaka, Japan. Public Works Research Institute. pp.333-347.
- City of Kobe. (1996) *Great Hanshin-Awaji Earthquake Disaster: Kobe City Record, 1995*. Kobe.
- Cho, S., P.Gordon, J.E. Moore II, H.W. Richardson, M. Shinozuka, and S.E. Chang. (2001). "Integrating Transportation Network and Regional Economic Models to Estimate the Costs of a Large Urban Earthquake," *Journal of Regional Science* **41**(1): 39-65.
- Cochrane, H.C. (1974). "Predicting the Economic Impact of Earthquakes." Boulder, Colorado. Institute of Behavioral Science, University of Colorado, Working Paper No.15.
- Cochrane, H.C. "Indirect Losses from Natural Disasters: Measurement and Myth." In Y. Okuyama and S.E. Chang, eds. *Modeling the Spatial Economic Impact of Disasters*. Springer-Verlag. Forthcoming.
- Durkin, M. E. (1984). "The Economic Recovery of Small Businesses after Earthquakes: The Coalinga Experience," paper presented at the International Conference on Natural Hazards Mitigation Research and Practice, New Delhi, India.
- EQE International. (1995) "The January 17, 1995 Kobe Earthquake: An EQE Summary Report." San Francisco: EQE.
- Gordon, P., H. W. Richardson and B. Davis (1998). "Transport-Related Impacts of the Northridge Earthquake." *Journal of Transportation and Statistics* **1**(2): 21-36.
- Haas, J. E., R. W. Kates, and M. Bowden, eds. (1977). *Reconstruction Following Disaster*. Cambridge, MA: MIT Press.
- Hewitt, K. (1997). *Regions of Risk: A Geographical Introduction to Disasters*. Essex, England: Addison Wesley Longman Limited.
- Hirayama, Y. (2000). "Collapse and Reconstruction: Housing Recovery Policy in Kobe after the Hanshin Great Earthquake." *Housing Studies* **15**(1): 111-128.
- Hogg, S. J. (1980). "Reconstruction Following Seismic Disaster in Venzone, Friuli." *Disasters* **4**(2): 173-185.
- Kawashima, K. and T. Kanoh (1990). "Evaluation of Indirect Economic Effects Caused by the 1983 Nihonkai-Chubu, Japan Earthquake." *Earthquake Spectra* **6**(4): 739-55.
- Kim, T.J., H. Ham and D. Boyce. (2000). "Economic Impacts of Transportation Network Changes: Implementation of a Combined Transportation Network and Input-Output Model," *Papers in Regional Science*, Vol.81, No.2, pp.223-246.
- Klosterman, R.E. (1994) "An Introduction to the Literature on Large-Scale Urban Models," *Journal of the American Planning Association*, Vol.60, No.1, pp.41-44.

- Kroll, C. A., J. D. Landis, Q. Shen, and S. Stryker. (1991). "Economic Impacts of the Loma Prieta Earthquake: A Focus on Small Businesses." Berkeley, CA: University of California at Berkeley, U.C. Transportation Center and the Center for Real Estate and Urban Economics, working paper #91-187.
- Landis, J. and M. Zhang. (1998) "The Second Generation of the California Urban Futures Model. Part 1: Model Logis and Theory," *Environment and Planning B*, Vol. 25, No.5, pp.657-666.
- Lee, D.B., Jr. (1973). "Requiem for Large-Scale Models," *Journal of the American Institute of Planners*, Vol.39, pp.163-178.
- Okuyama, Y., G. J. D. Hewings and M. Sonis (2000). "Sequential Interindustry Model (SIM) and Impact Analysis: Application for Measuring Economic Impact of Unscheduled Events," paper presented at the 47<sup>th</sup> North American Meetings of the Regional Science Association International, Chicago, IL.
- Rose, A., J. Benavides, S. E. Chang, P. Szczesniak and D. Lim (1997). "The Regional Economic Impact of an Earthquake: Direct and Indirect Effects of Electricity Lifeline Disruptions." *Journal of Regional Science* 37(3): 437-458.
- Rose, A. and G. Guha (1999). "Computable General Equilibrium Modeling of Electric Utility Lifeline Losses from Earthquakes," paper presented at the 46<sup>th</sup> North American Meetings of the Regional Science Association International, Montreal, Canada.
- Rubin, C. (1991). "Recovery from Disaster," in *Emergency Management: Principles and Practice for Local Government*. Eds. T. E. Drabek and G. J. Hoetmer. Washington, D.C., ICMA: 224-259.
- Rubin, C. B. and R. Popkin. (1990). "Disaster Recovery after Hurricane Hugo in South Carolina." Boulder, CO, Institute of Behavioral Science, University of Colorado.
- Rumbaugh, J., M. Blaha, W. Premerlani, F. Eddy, and W. Lorenson. (1991). *Object-Oriented Modeling and Design*. Upper Saddle River, NJ: Prentice-Hall.
- Simpson, D.M. (2001) "Virtual Reality and Urban Simulation in Planning: A Literature Review and Topical Bibliography," *Journal of Planning Literature*, Vol.15, No.3, pp. 359-376.
- Tierney, K. J. and J. M. Dahlhamer (1998). "Business Disruption, Preparedness and Recovery: Lessons from the Northridge Earthquake." *NEHRP Conference and Workshop on Research on the Northridge, California Earthquake of January 17, 1994*, Richmond, CA: CUREe.
- Waddell, P. (2002). "UrbanSim: Modeling Urban Development for Land Use, Transportation, and Environmental Planning," *Journal of the American Planning Association*, Vol.68, No.3, pp.297-314.

- Waddell, P. and G.F. Ulfarsson. "Introduction to Urban Simulation: Design and Development of Operational Models," in Stopher, Button, Kingsley, and Hensher, eds., *Handbook in Transport*, Volume 5: Transport Geography and Spatial Systems, Pergamon Press. Forthcoming. Available at: <http://www.urbansim.org/papers/index.shtml>.
- Wegener, M. (1994) "Operational Urban Models: State of the Art," *Journal of the American Planning Association*, Vol.60, No.1, pp.17-29.
- West, C. T. and D. G. Lenze (1994). "Modeling the Regional Impact of Natural Disaster and Recovery: A General Framework and an Application to Hurricane Andrew." *International Regional Science Review* **17**(2): 121-150.



## Appendix A

### Narrative Basis of Model

*The following narrative formed the starting point for the problem definition stage of the Object Modeling Technique (OMT) (see Section 4.1):*

The focus of this model is on simulating urban disaster recovery and the potential effects on recovery of response and short-term recovery decisions, with emphasis on water and electric power lifeline restoration decisions. We are trying to capture the insight that emergency response and recovery decisions affect household and business recovery, and through their interactions, have spatial implications for urban disaster recovery.

We begin with a baseline urban area that will experience an earthquake disaster some time in the future. It is situated in some physical setting that includes areas prone to stronger ground motion, landslide, liquefaction, etc. It contains a building stock that has been accumulated over time and space. The building stock changes each year as new buildings are added and deleted (according to population change). Some types of buildings are more seismically vulnerable than others. In a simplified sense, newer buildings are presumed to be more seismically resistant than older ones, so the building stock tends to improve over time. There are critical facilities such as hospitals. The urban area is served by lifeline networks, including transportation, water, and electric power networks. We can make some assumptions about the vulnerability of different types of structures, incorporating possibly some degree of mitigation, though this is not necessary for demonstration.

Throughout the urban area are households with various income levels. The households inhabit the housing stock. We can start with an existing population/buildings/ infrastructure configuration in the urban space, perhaps at the level of neighborhoods. At each time period, various characteristics of the neighborhood

(transportation costs, access to jobs and amenities, housing price) are computed; these figure into households' locational choices in the next period. They [the households] make locational choices based on income, housing prices, and commute costs. For the sake of simplicity, we can assume that only new households choose locations in each time period (year); existing ones stay where they are. Certain areas are wealthier than others. Households provide labor input to businesses and derive income from this. They use their income to purchase goods and services, primarily from businesses in the local area. They make decisions as to where to locate. There may be net in-migration to the area. Households can move out of the area.

The area is also populated by businesses. These purchase inputs, including labor and materials, and produce outputs. Profits (revenues less costs) might be evaluated quarterly, with a series of unprofitable quarters (e.g., after earthquake) leading to business closure. Some businesses produce for local markets, and others for export. Those that produce for local markets to consumers are distributed in space in relation to the household locations. Their quarterly revenues would depend on local population (and households' incomes) in that quarter. Those producing for export may be more clustered, for example around transportation nodes. Businesses may close or change locations. New businesses may appear.

An earthquake strikes the urban area. Buildings and lifeline networks are damaged in the immediate aftermath. Pervasiveness of building damage (both housing and business), as well as lifeline outage, vary over space. Households suffer varying degrees of injury/death, dislocation, and disruption. Dislocation may be caused by damage to housing and/or loss of lifeline services. It results in seeking emergency shelter and/or relocation and/or not being able to go to work for a while. The timeframe for dislocation depends on housing damage, lifeline restoration, and public decisions about reconstruction timeframes (e.g., regulation waivers to speed up rebuilding). Businesses suffer disruption due to employees not showing up for work, damage to structures, lifeline disruption, and in some cases loss of customers (if local). Business loss from these factors can be calculated in terms of effects on profits at weekly time intervals; however, some times of production loss may be made up after repairs are underway. Businesses may close temporarily, curtail production and labor requirements, and/or

relocate during the recovery period. If disruption is suffered for a long time, some businesses may close.

In the initial days and weeks following the disaster, public and quasi-public agencies make decisions that will affect the recovery of the urban area. Government prioritizes rescue efforts. Fires are fought – more or less successfully, depending on the condition of lifeline systems and available fire-fighting resources. Government requests mutual aid. Emergency shelters and short-term emergency housing is set up in certain areas. Government assesses damage according to previously planned inspection thresholds and sets up emergency shelters. Displaced households are assigned to these and in many cases will stay in short-term housing for quite a long time. There may be decisions made about expediting damage inspection and reconstruction permitting. Debris is cleared. There will be debates about potential land uses changes in areas that were shown to be particularly vulnerable to earthquake hazard. This may delay reconstruction in those areas. Once any debates are settled, repairs are initiated. Households return to damaged homes (leave shelters/short-term housing) once repairs are completed and lifeline service is restored. Lifeline agencies may make decisions to expedite repairs and restore service (e.g., by calling in mutual aid crews), prioritize repairs, prioritize service restoration to critical facilities, sequence repairs/restoration (usually least damaged areas get restored first), and provide for emergency service. There is a tradeoff between the speed with which repairs are made and the level of seismic resistance incorporated in the repairs for future earthquakes.

Households' recovery will be influenced primarily by the speed with which their housing, lifeline service (inc. transportation), and jobs are returned to normal. During recovery, if their jobs and income streams are disrupted, they may curtail consumption of some kinds of goods. The speed of housing restoration is strongly influenced by conditions of reconstruction finance. A certain proportion of the households will have had insurance, which will provide the most rapid form of finance (other than savings). Others will rely mostly on government assistance, which may be more limited and take longer to receive. All things equal, wealthier households will recover faster because they have more resources for recovery.

Business recovery will be influenced by the speed with which business structures and equipment, lifeline service, and households' labor inputs are returned to normal. The speed of business reconstruction will be influenced by reconstruction finance. Some may have insurance, others may apply for government loans and grants, and many will finance repairs from internal resources. Businesses serving local markets will have more difficulty recovering than export-oriented firms because their customers will also have been impacted by the disaster. All things equal, larger businesses will recover faster because they have more resources for recovery, might have multi-plant operations and could substitute between them, etc.

There will be interaction between households and businesses across space, via the channels noted above. Certain areas will recover more quickly than others due to these interactions. For example, lag areas may form: certain heavily damaged areas with slow lifeline restoration may experience much population displacement to short-term housing, loss of customers for local stores and service establishments, disproportionately high business closures, slow return of residents, etc.

## **Multidisciplinary Center for Earthquake Engineering Research List of Technical Reports**

The Multidisciplinary Center for Earthquake Engineering Research (MCEER) publishes technical reports on a variety of subjects related to earthquake engineering written by authors funded through MCEER. These reports are available from both MCEER Publications and the National Technical Information Service (NTIS). Requests for reports should be directed to MCEER Publications, Multidisciplinary Center for Earthquake Engineering Research, State University of New York at Buffalo, Red Jacket Quadrangle, Buffalo, New York 14261. Reports can also be requested through NTIS, 5285 Port Royal Road, Springfield, Virginia 22161. NTIS accession numbers are shown in parenthesis, if available.

- NCEER-87-0001 "First-Year Program in Research, Education and Technology Transfer," 3/5/87, (PB88-134275, A04, MF-A01).
- NCEER-87-0002 "Experimental Evaluation of Instantaneous Optimal Algorithms for Structural Control," by R.C. Lin, T.T. Soong and A.M. Reinhorn, 4/20/87, (PB88-134341, A04, MF-A01).
- NCEER-87-0003 "Experimentation Using the Earthquake Simulation Facilities at University at Buffalo," by A.M. Reinhorn and R.L. Ketter, to be published.
- NCEER-87-0004 "The System Characteristics and Performance of a Shaking Table," by J.S. Hwang, K.C. Chang and G.C. Lee, 6/1/87, (PB88-134259, A03, MF-A01). This report is available only through NTIS (see address given above).
- NCEER-87-0005 "A Finite Element Formulation for Nonlinear Viscoplastic Material Using a Q Model," by O. Gyebe and G. Dasgupta, 11/2/87, (PB88-213764, A08, MF-A01).
- NCEER-87-0006 "Symbolic Manipulation Program (SMP) - Algebraic Codes for Two and Three Dimensional Finite Element Formulations," by X. Lee and G. Dasgupta, 11/9/87, (PB88-218522, A05, MF-A01).
- NCEER-87-0007 "Instantaneous Optimal Control Laws for Tall Buildings Under Seismic Excitations," by J.N. Yang, A. Akbarpour and P. Ghaemmaghami, 6/10/87, (PB88-134333, A06, MF-A01). This report is only available through NTIS (see address given above).
- NCEER-87-0008 "IDARC: Inelastic Damage Analysis of Reinforced Concrete Frame - Shear-Wall Structures," by Y.J. Park, A.M. Reinhorn and S.K. Kunnath, 7/20/87, (PB88-134325, A09, MF-A01). This report is only available through NTIS (see address given above).
- NCEER-87-0009 "Liquefaction Potential for New York State: A Preliminary Report on Sites in Manhattan and Buffalo," by M. Budhu, V. Vijayakumar, R.F. Giese and L. Baumgras, 8/31/87, (PB88-163704, A03, MF-A01). This report is available only through NTIS (see address given above).
- NCEER-87-0010 "Vertical and Torsional Vibration of Foundations in Inhomogeneous Media," by A.S. Veletsos and K.W. Dotson, 6/1/87, (PB88-134291, A03, MF-A01). This report is only available through NTIS (see address given above).
- NCEER-87-0011 "Seismic Probabilistic Risk Assessment and Seismic Margins Studies for Nuclear Power Plants," by Howard H.M. Hwang, 6/15/87, (PB88-134267, A03, MF-A01). This report is only available through NTIS (see address given above).
- NCEER-87-0012 "Parametric Studies of Frequency Response of Secondary Systems Under Ground-Acceleration Excitations," by Y. Yong and Y.K. Lin, 6/10/87, (PB88-134309, A03, MF-A01). This report is only available through NTIS (see address given above).
- NCEER-87-0013 "Frequency Response of Secondary Systems Under Seismic Excitation," by J.A. HoLung, J. Cai and Y.K. Lin, 7/31/87, (PB88-134317, A05, MF-A01). This report is only available through NTIS (see address given above).
- NCEER-87-0014 "Modelling Earthquake Ground Motions in Seismically Active Regions Using Parametric Time Series Methods," by G.W. Ellis and A.S. Cakmak, 8/25/87, (PB88-134283, A08, MF-A01). This report is only available through NTIS (see address given above).

- NCEER-87-0015 "Detection and Assessment of Seismic Structural Damage," by E. DiPasquale and A.S. Cakmak, 8/25/87, (PB88-163712, A05, MF-A01). This report is only available through NTIS (see address given above).
- NCEER-87-0016 "Pipeline Experiment at Parkfield, California," by J. Isenberg and E. Richardson, 9/15/87, (PB88-163720, A03, MF-A01). This report is available only through NTIS (see address given above).
- NCEER-87-0017 "Digital Simulation of Seismic Ground Motion," by M. Shinozuka, G. Deodatis and T. Harada, 8/31/87, (PB88-155197, A04, MF-A01). This report is available only through NTIS (see address given above).
- NCEER-87-0018 "Practical Considerations for Structural Control: System Uncertainty, System Time Delay and Truncation of Small Control Forces," J.N. Yang and A. Akbarpour, 8/10/87, (PB88-163738, A08, MF-A01). This report is only available through NTIS (see address given above).
- NCEER-87-0019 "Modal Analysis of Nonclassically Damped Structural Systems Using Canonical Transformation," by J.N. Yang, S. Sarkani and F.X. Long, 9/27/87, (PB88-187851, A04, MF-A01).
- NCEER-87-0020 "A Nonstationary Solution in Random Vibration Theory," by J.R. Red-Horse and P.D. Spanos, 11/3/87, (PB88-163746, A03, MF-A01).
- NCEER-87-0021 "Horizontal Impedances for Radially Inhomogeneous Viscoelastic Soil Layers," by A.S. Veletsos and K.W. Dotson, 10/15/87, (PB88-150859, A04, MF-A01).
- NCEER-87-0022 "Seismic Damage Assessment of Reinforced Concrete Members," by Y.S. Chung, C. Meyer and M. Shinozuka, 10/9/87, (PB88-150867, A05, MF-A01). This report is available only through NTIS (see address given above).
- NCEER-87-0023 "Active Structural Control in Civil Engineering," by T.T. Soong, 11/11/87, (PB88-187778, A03, MF-A01).
- NCEER-87-0024 "Vertical and Torsional Impedances for Radially Inhomogeneous Viscoelastic Soil Layers," by K.W. Dotson and A.S. Veletsos, 12/87, (PB88-187786, A03, MF-A01).
- NCEER-87-0025 "Proceedings from the Symposium on Seismic Hazards, Ground Motions, Soil-Liquefaction and Engineering Practice in Eastern North America," October 20-22, 1987, edited by K.H. Jacob, 12/87, (PB88-188115, A23, MF-A01). This report is available only through NTIS (see address given above).
- NCEER-87-0026 "Report on the Whittier-Narrows, California, Earthquake of October 1, 1987," by J. Pantelic and A. Reinhorn, 11/87, (PB88-187752, A03, MF-A01). This report is available only through NTIS (see address given above).
- NCEER-87-0027 "Design of a Modular Program for Transient Nonlinear Analysis of Large 3-D Building Structures," by S. Srivastav and J.F. Abel, 12/30/87, (PB88-187950, A05, MF-A01). This report is only available through NTIS (see address given above).
- NCEER-87-0028 "Second-Year Program in Research, Education and Technology Transfer," 3/8/88, (PB88-219480, A04, MF-A01).
- NCEER-88-0001 "Workshop on Seismic Computer Analysis and Design of Buildings With Interactive Graphics," by W. McGuire, J.F. Abel and C.H. Conley, 1/18/88, (PB88-187760, A03, MF-A01). This report is only available through NTIS (see address given above).
- NCEER-88-0002 "Optimal Control of Nonlinear Flexible Structures," by J.N. Yang, F.X. Long and D. Wong, 1/22/88, (PB88-213772, A06, MF-A01).
- NCEER-88-0003 "Substructuring Techniques in the Time Domain for Primary-Secondary Structural Systems," by G.D. Manolis and G. Juhn, 2/10/88, (PB88-213780, A04, MF-A01).
- NCEER-88-0004 "Iterative Seismic Analysis of Primary-Secondary Systems," by A. Singhal, L.D. Lutes and P.D. Spanos, 2/23/88, (PB88-213798, A04, MF-A01).

- NCEER-88-0005 "Stochastic Finite Element Expansion for Random Media," by P.D. Spanos and R. Ghanem, 3/14/88, (PB88-213806, A03, MF-A01).
- NCEER-88-0006 "Combining Structural Optimization and Structural Control," by F.Y. Cheng and C.P. Pantelides, 1/10/88, (PB88-213814, A05, MF-A01).
- NCEER-88-0007 "Seismic Performance Assessment of Code-Designed Structures," by H.H-M. Hwang, J-W. Jaw and H-J. Shau, 3/20/88, (PB88-219423, A04, MF-A01). This report is only available through NTIS (see address given above).
- NCEER-88-0008 "Reliability Analysis of Code-Designed Structures Under Natural Hazards," by H.H-M. Hwang, H. Ushiba and M. Shinozuka, 2/29/88, (PB88-229471, A07, MF-A01). This report is only available through NTIS (see address given above).
- NCEER-88-0009 "Seismic Fragility Analysis of Shear Wall Structures," by J-W Jaw and H.H-M. Hwang, 4/30/88, (PB89-102867, A04, MF-A01).
- NCEER-88-0010 "Base Isolation of a Multi-Story Building Under a Harmonic Ground Motion - A Comparison of Performances of Various Systems," by F-G Fan, G. Ahmadi and I.G. Tadjbakhsh, 5/18/88, (PB89-122238, A06, MF-A01). This report is only available through NTIS (see address given above).
- NCEER-88-0011 "Seismic Floor Response Spectra for a Combined System by Green's Functions," by F.M. Lavelle, L.A. Bergman and P.D. Spanos, 5/1/88, (PB89-102875, A03, MF-A01).
- NCEER-88-0012 "A New Solution Technique for Randomly Excited Hysteretic Structures," by G.Q. Cai and Y.K. Lin, 5/16/88, (PB89-102883, A03, MF-A01).
- NCEER-88-0013 "A Study of Radiation Damping and Soil-Structure Interaction Effects in the Centrifuge," by K. Weissman, supervised by J.H. Prevost, 5/24/88, (PB89-144703, A06, MF-A01).
- NCEER-88-0014 "Parameter Identification and Implementation of a Kinematic Plasticity Model for Frictional Soils," by J.H. Prevost and D.V. Griffiths, to be published.
- NCEER-88-0015 "Two- and Three- Dimensional Dynamic Finite Element Analyses of the Long Valley Dam," by D.V. Griffiths and J.H. Prevost, 6/17/88, (PB89-144711, A04, MF-A01).
- NCEER-88-0016 "Damage Assessment of Reinforced Concrete Structures in Eastern United States," by A.M. Reinhorn, M.J. Seidel, S.K. Kunnath and Y.J. Park, 6/15/88, (PB89-122220, A04, MF-A01). This report is only available through NTIS (see address given above).
- NCEER-88-0017 "Dynamic Compliance of Vertically Loaded Strip Foundations in Multilayered Viscoelastic Soils," by S. Ahmad and A.S.M. Israil, 6/17/88, (PB89-102891, A04, MF-A01).
- NCEER-88-0018 "An Experimental Study of Seismic Structural Response With Added Viscoelastic Dampers," by R.C. Lin, Z. Liang, T.T. Soong and R.H. Zhang, 6/30/88, (PB89-122212, A05, MF-A01). This report is available only through NTIS (see address given above).
- NCEER-88-0019 "Experimental Investigation of Primary - Secondary System Interaction," by G.D. Manolis, G. Juhn and A.M. Reinhorn, 5/27/88, (PB89-122204, A04, MF-A01).
- NCEER-88-0020 "A Response Spectrum Approach For Analysis of Nonclassically Damped Structures," by J.N. Yang, S. Sarkani and F.X. Long, 4/22/88, (PB89-102909, A04, MF-A01).
- NCEER-88-0021 "Seismic Interaction of Structures and Soils: Stochastic Approach," by A.S. Veletsos and A.M. Prasad, 7/21/88, (PB89-122196, A04, MF-A01). This report is only available through NTIS (see address given above).
- NCEER-88-0022 "Identification of the Serviceability Limit State and Detection of Seismic Structural Damage," by E. DiPasquale and A.S. Cakmak, 6/15/88, (PB89-122188, A05, MF-A01). This report is available only through NTIS (see address given above).

- NCEER-88-0023 "Multi-Hazard Risk Analysis: Case of a Simple Offshore Structure," by B.K. Bhartia and E.H. Vanmarcke, 7/21/88, (PB89-145213, A05, MF-A01).
- NCEER-88-0024 "Automated Seismic Design of Reinforced Concrete Buildings," by Y.S. Chung, C. Meyer and M. Shinozuka, 7/5/88, (PB89-122170, A06, MF-A01). This report is available only through NTIS (see address given above).
- NCEER-88-0025 "Experimental Study of Active Control of MDOF Structures Under Seismic Excitations," by L.L. Chung, R.C. Lin, T.T. Soong and A.M. Reinhorn, 7/10/88, (PB89-122600, A04, MF-A01).
- NCEER-88-0026 "Earthquake Simulation Tests of a Low-Rise Metal Structure," by J.S. Hwang, K.C. Chang, G.C. Lee and R.L. Ketter, 8/1/88, (PB89-102917, A04, MF-A01).
- NCEER-88-0027 "Systems Study of Urban Response and Reconstruction Due to Catastrophic Earthquakes," by F. Kozin and H.K. Zhou, 9/22/88, (PB90-162348, A04, MF-A01).
- NCEER-88-0028 "Seismic Fragility Analysis of Plane Frame Structures," by H.H-M. Hwang and Y.K. Low, 7/31/88, (PB89-131445, A06, MF-A01).
- NCEER-88-0029 "Response Analysis of Stochastic Structures," by A. Kardara, C. Bucher and M. Shinozuka, 9/22/88, (PB89-174429, A04, MF-A01).
- NCEER-88-0030 "Nonnormal Accelerations Due to Yielding in a Primary Structure," by D.C.K. Chen and L.D. Lutes, 9/19/88, (PB89-131437, A04, MF-A01).
- NCEER-88-0031 "Design Approaches for Soil-Structure Interaction," by A.S. Veletsos, A.M. Prasad and Y. Tang, 12/30/88, (PB89-174437, A03, MF-A01). This report is available only through NTIS (see address given above).
- NCEER-88-0032 "A Re-evaluation of Design Spectra for Seismic Damage Control," by C.J. Turkstra and A.G. Tallin, 11/7/88, (PB89-145221, A05, MF-A01).
- NCEER-88-0033 "The Behavior and Design of Noncontact Lap Splices Subjected to Repeated Inelastic Tensile Loading," by V.E. Sagan, P. Gergely and R.N. White, 12/8/88, (PB89-163737, A08, MF-A01).
- NCEER-88-0034 "Seismic Response of Pile Foundations," by S.M. Mamoon, P.K. Banerjee and S. Ahmad, 11/1/88, (PB89-145239, A04, MF-A01).
- NCEER-88-0035 "Modeling of R/C Building Structures With Flexible Floor Diaphragms (IDARC2)," by A.M. Reinhorn, S.K. Kunnath and N. Panahshahi, 9/7/88, (PB89-207153, A07, MF-A01).
- NCEER-88-0036 "Solution of the Dam-Reservoir Interaction Problem Using a Combination of FEM, BEM with Particular Integrals, Modal Analysis, and Substructuring," by C-S. Tsai, G.C. Lee and R.L. Ketter, 12/31/88, (PB89-207146, A04, MF-A01).
- NCEER-88-0037 "Optimal Placement of Actuators for Structural Control," by F.Y. Cheng and C.P. Pantelides, 8/15/88, (PB89-162846, A05, MF-A01).
- NCEER-88-0038 "Teflon Bearings in Aseismic Base Isolation: Experimental Studies and Mathematical Modeling," by A. Mokha, M.C. Constantinou and A.M. Reinhorn, 12/5/88, (PB89-218457, A10, MF-A01). This report is available only through NTIS (see address given above).
- NCEER-88-0039 "Seismic Behavior of Flat Slab High-Rise Buildings in the New York City Area," by P. Weidlinger and M. Ettouney, 10/15/88, (PB90-145681, A04, MF-A01).
- NCEER-88-0040 "Evaluation of the Earthquake Resistance of Existing Buildings in New York City," by P. Weidlinger and M. Ettouney, 10/15/88, to be published.
- NCEER-88-0041 "Small-Scale Modeling Techniques for Reinforced Concrete Structures Subjected to Seismic Loads," by W. Kim, A. El-Attar and R.N. White, 11/22/88, (PB89-189625, A05, MF-A01).



- NCEER-88-0042 "Modeling Strong Ground Motion from Multiple Event Earthquakes," by G.W. Ellis and A.S. Cakmak, 10/15/88, (PB89-174445, A03, MF-A01).
- NCEER-88-0043 "Nonstationary Models of Seismic Ground Acceleration," by M. Grigoriu, S.E. Ruiz and E. Rosenblueth, 7/15/88, (PB89-189617, A04, MF-A01).
- NCEER-88-0044 "SARCF User's Guide: Seismic Analysis of Reinforced Concrete Frames," by Y.S. Chung, C. Meyer and M. Shinozuka, 11/9/88, (PB89-174452, A08, MF-A01).
- NCEER-88-0045 "First Expert Panel Meeting on Disaster Research and Planning," edited by J. Pantelic and J. Stoyale, 9/15/88, (PB89-174460, A05, MF-A01).
- NCEER-88-0046 "Preliminary Studies of the Effect of Degrading Infill Walls on the Nonlinear Seismic Response of Steel Frames," by C.Z. Chrysostomou, P. Gergely and J.F. Abel, 12/19/88, (PB89-208383, A05, MF-A01).
- NCEER-88-0047 "Reinforced Concrete Frame Component Testing Facility - Design, Construction, Instrumentation and Operation," by S.P. Pessiki, C. Conley, T. Bond, P. Gergely and R.N. White, 12/16/88, (PB89-174478, A04, MF-A01).
- NCEER-89-0001 "Effects of Protective Cushion and Soil Compliancy on the Response of Equipment Within a Seismically Excited Building," by J.A. HoLung, 2/16/89, (PB89-207179, A04, MF-A01).
- NCEER-89-0002 "Statistical Evaluation of Response Modification Factors for Reinforced Concrete Structures," by H.H-M. Hwang and J-W. Jaw, 2/17/89, (PB89-207187, A05, MF-A01).
- NCEER-89-0003 "Hysteretic Columns Under Random Excitation," by G-Q. Cai and Y.K. Lin, 1/9/89, (PB89-196513, A03, MF-A01).
- NCEER-89-0004 "Experimental Study of 'Elephant Foot Bulge' Instability of Thin-Walled Metal Tanks," by Z-H. Jia and R.L. Ketter, 2/22/89, (PB89-207195, A03, MF-A01).
- NCEER-89-0005 "Experiment on Performance of Buried Pipelines Across San Andreas Fault," by J. Isenberg, E. Richardson and T.D. O'Rourke, 3/10/89, (PB89-218440, A04, MF-A01). This report is available only through NTIS (see address given above).
- NCEER-89-0006 "A Knowledge-Based Approach to Structural Design of Earthquake-Resistant Buildings," by M. Subramani, P. Gergely, C.H. Conley, J.F. Abel and A.H. Zaghaw, 1/15/89, (PB89-218465, A06, MF-A01).
- NCEER-89-0007 "Liquefaction Hazards and Their Effects on Buried Pipelines," by T.D. O'Rourke and P.A. Lane, 2/1/89, (PB89-218481, A09, MF-A01).
- NCEER-89-0008 "Fundamentals of System Identification in Structural Dynamics," by H. Imai, C-B. Yun, O. Maruyama and M. Shinozuka, 1/26/89, (PB89-207211, A04, MF-A01).
- NCEER-89-0009 "Effects of the 1985 Michoacan Earthquake on Water Systems and Other Buried Lifelines in Mexico," by A.G. Ayala and M.J. O'Rourke, 3/8/89, (PB89-207229, A06, MF-A01).
- NCEER-89-R010 "NCEER Bibliography of Earthquake Education Materials," by K.E.K. Ross, Second Revision, 9/1/89, (PB90-125352, A05, MF-A01). This report is replaced by NCEER-92-0018.
- NCEER-89-0011 "Inelastic Three-Dimensional Response Analysis of Reinforced Concrete Building Structures (IDARC-3D), Part I - Modeling," by S.K. Kunnath and A.M. Reinhorn, 4/17/89, (PB90-114612, A07, MF-A01). This report is available only through NTIS (see address given above).
- NCEER-89-0012 "Recommended Modifications to ATC-14," by C.D. Poland and J.O. Malley, 4/12/89, (PB90-108648, A15, MF-A01).
- NCEER-89-0013 "Repair and Strengthening of Beam-to-Column Connections Subjected to Earthquake Loading," by M. Corazao and A.J. Durrani, 2/28/89, (PB90-109885, A06, MF-A01).

- NCEER-89-0014 "Program EXKAL2 for Identification of Structural Dynamic Systems," by O. Maruyama, C-B. Yun, M. Hoshiya and M. Shinozuka, 5/19/89, (PB90-109877, A09, MF-A01).
- NCEER-89-0015 "Response of Frames With Bolted Semi-Rigid Connections, Part I - Experimental Study and Analytical Predictions," by P.J. DiCorso, A.M. Reinhorn, J.R. Dickerson, J.B. Radzinski and W.L. Harper, 6/1/89, to be published.
- NCEER-89-0016 "ARMA Monte Carlo Simulation in Probabilistic Structural Analysis," by P.D. Spanos and M.P. Mignolet, 7/10/89, (PB90-109893, A03, MF-A01).
- NCEER-89-P017 "Preliminary Proceedings from the Conference on Disaster Preparedness - The Place of Earthquake Education in Our Schools," Edited by K.E.K. Ross, 6/23/89, (PB90-108606, A03, MF-A01).
- NCEER-89-0017 "Proceedings from the Conference on Disaster Preparedness - The Place of Earthquake Education in Our Schools," Edited by K.E.K. Ross, 12/31/89, (PB90-207895, A012, MF-A02). This report is available only through NTIS (see address given above).
- NCEER-89-0018 "Multidimensional Models of Hysteretic Material Behavior for Vibration Analysis of Shape Memory Energy Absorbing Devices, by E.J. Graesser and F.A. Cozzarelli, 6/7/89, (PB90-164146, A04, MF-A01).
- NCEER-89-0019 "Nonlinear Dynamic Analysis of Three-Dimensional Base Isolated Structures (3D-BASIS)," by S. Nagarajaiah, A.M. Reinhorn and M.C. Constantinou, 8/3/89, (PB90-161936, A06, MF-A01). This report has been replaced by NCEER-93-0011.
- NCEER-89-0020 "Structural Control Considering Time-Rate of Control Forces and Control Rate Constraints," by F.Y. Cheng and C.P. Pantelides, 8/3/89, (PB90-120445, A04, MF-A01).
- NCEER-89-0021 "Subsurface Conditions of Memphis and Shelby County," by K.W. Ng, T-S. Chang and H-H.M. Hwang, 7/26/89, (PB90-120437, A03, MF-A01).
- NCEER-89-0022 "Seismic Wave Propagation Effects on Straight Jointed Buried Pipelines," by K. Elhadi and M.J. O'Rourke, 8/24/89, (PB90-162322, A10, MF-A02).
- NCEER-89-0023 "Workshop on Serviceability Analysis of Water Delivery Systems," edited by M. Grigoriu, 3/6/89, (PB90-127424, A03, MF-A01).
- NCEER-89-0024 "Shaking Table Study of a 1/5 Scale Steel Frame Composed of Tapered Members," by K.C. Chang, J.S. Hwang and G.C. Lee, 9/18/89, (PB90-160169, A04, MF-A01).
- NCEER-89-0025 "DYNA1D: A Computer Program for Nonlinear Seismic Site Response Analysis - Technical Documentation," by Jean H. Prevost, 9/14/89, (PB90-161944, A07, MF-A01). This report is available only through NTIS (see address given above).
- NCEER-89-0026 "1:4 Scale Model Studies of Active Tendon Systems and Active Mass Dampers for Aseismic Protection," by A.M. Reinhorn, T.T. Soong, R.C. Lin, Y.P. Yang, Y. Fukao, H. Abe and M. Nakai, 9/15/89, (PB90-173246, A10, MF-A02). This report is available only through NTIS (see address given above).
- NCEER-89-0027 "Scattering of Waves by Inclusions in a Nonhomogeneous Elastic Half Space Solved by Boundary Element Methods," by P.K. Hadley, A. Askar and A.S. Cakmak, 6/15/89, (PB90-145699, A07, MF-A01).
- NCEER-89-0028 "Statistical Evaluation of Deflection Amplification Factors for Reinforced Concrete Structures," by H.H.M. Hwang, J-W. Jaw and A.L. Ch'ng, 8/31/89, (PB90-164633, A05, MF-A01).
- NCEER-89-0029 "Bedrock Accelerations in Memphis Area Due to Large New Madrid Earthquakes," by H.H.M. Hwang, C.H.S. Chen and G. Yu, 11/7/89, (PB90-162330, A04, MF-A01).
- NCEER-89-0030 "Seismic Behavior and Response Sensitivity of Secondary Structural Systems," by Y.Q. Chen and T.T. Soong, 10/23/89, (PB90-164658, A08, MF-A01).
- NCEER-89-0031 "Random Vibration and Reliability Analysis of Primary-Secondary Structural Systems," by Y. Ibrahim, M. Grigoriu and T.T. Soong, 11/10/89, (PB90-161951, A04, MF-A01).

- NCEER-89-0032 "Proceedings from the Second U.S. - Japan Workshop on Liquefaction, Large Ground Deformation and Their Effects on Lifelines, September 26-29, 1989," Edited by T.D. O'Rourke and M. Hamada, 12/1/89, (PB90-209388, A22, MF-A03).
- NCEER-89-0033 "Deterministic Model for Seismic Damage Evaluation of Reinforced Concrete Structures," by J.M. Bracci, A.M. Reinhorn, J.B. Mander and S.K. Kunnath, 9/27/89, (PB91-108803, A06, MF-A01).
- NCEER-89-0034 "On the Relation Between Local and Global Damage Indices," by E. DiPasquale and A.S. Cakmak, 8/15/89, (PB90-173865, A05, MF-A01).
- NCEER-89-0035 "Cyclic Undrained Behavior of Nonplastic and Low Plasticity Silts," by A.J. Walker and H.E. Stewart, 7/26/89, (PB90-183518, A10, MF-A01).
- NCEER-89-0036 "Liquefaction Potential of Surficial Deposits in the City of Buffalo, New York," by M. Budhu, R. Giese and L. Baumgrass, 1/17/89, (PB90-208455, A04, MF-A01).
- NCEER-89-0037 "A Deterministic Assessment of Effects of Ground Motion Incoherence," by A.S. Veletsos and Y. Tang, 7/15/89, (PB90-164294, A03, MF-A01).
- NCEER-89-0038 "Workshop on Ground Motion Parameters for Seismic Hazard Mapping," July 17-18, 1989, edited by R.V. Whitman, 12/1/89, (PB90-173923, A04, MF-A01).
- NCEER-89-0039 "Seismic Effects on Elevated Transit Lines of the New York City Transit Authority," by C.J. Costantino, C.A. Miller and E. Heymsfield, 12/26/89, (PB90-207887, A06, MF-A01).
- NCEER-89-0040 "Centrifugal Modeling of Dynamic Soil-Structure Interaction," by K. Weissman, Supervised by J.H. Prevost, 5/10/89, (PB90-207879, A07, MF-A01).
- NCEER-89-0041 "Linearized Identification of Buildings With Cores for Seismic Vulnerability Assessment," by I-K. Ho and A.E. Aktan, 11/1/89, (PB90-251943, A07, MF-A01).
- NCEER-90-0001 "Geotechnical and Lifeline Aspects of the October 17, 1989 Loma Prieta Earthquake in San Francisco," by T.D. O'Rourke, H.E. Stewart, F.T. Blackburn and T.S. Dickerman, 1/90, (PB90-208596, A05, MF-A01).
- NCEER-90-0002 "Nonnormal Secondary Response Due to Yielding in a Primary Structure," by D.C.K. Chen and L.D. Lutes, 2/28/90, (PB90-251976, A07, MF-A01).
- NCEER-90-0003 "Earthquake Education Materials for Grades K-12," by K.E.K. Ross, 4/16/90, (PB91-251984, A05, MF-A05). This report has been replaced by NCEER-92-0018.
- NCEER-90-0004 "Catalog of Strong Motion Stations in Eastern North America," by R.W. Busby, 4/3/90, (PB90-251984, A05, MF-A01).
- NCEER-90-0005 "NCEER Strong-Motion Data Base: A User Manual for the GeoBase Release (Version 1.0 for the Sun3)," by P. Friberg and K. Jacob, 3/31/90 (PB90-258062, A04, MF-A01).
- NCEER-90-0006 "Seismic Hazard Along a Crude Oil Pipeline in the Event of an 1811-1812 Type New Madrid Earthquake," by H.H.M. Hwang and C-H.S. Chen, 4/16/90, (PB90-258054, A04, MF-A01).
- NCEER-90-0007 "Site-Specific Response Spectra for Memphis Sheahan Pumping Station," by H.H.M. Hwang and C.S. Lee, 5/15/90, (PB91-108811, A05, MF-A01).
- NCEER-90-0008 "Pilot Study on Seismic Vulnerability of Crude Oil Transmission Systems," by T. Ariman, R. Dobry, M. Grigoriu, F. Kozin, M. O'Rourke, T. O'Rourke and M. Shinozuka, 5/25/90, (PB91-108837, A06, MF-A01).
- NCEER-90-0009 "A Program to Generate Site Dependent Time Histories: EQGEN," by G.W. Ellis, M. Srinivasan and A.S. Cakmak, 1/30/90, (PB91-108829, A04, MF-A01).
- NCEER-90-0010 "Active Isolation for Seismic Protection of Operating Rooms," by M.E. Talbott, Supervised by M. Shinozuka, 6/8/9, (PB91-110205, A05, MF-A01).

- NCEER-90-0011 "Program LINEARID for Identification of Linear Structural Dynamic Systems," by C-B. Yun and M. Shinozuka, 6/25/90, (PB91-110312, A08, MF-A01).
- NCEER-90-0012 "Two-Dimensional Two-Phase Elasto-Plastic Seismic Response of Earth Dams," by A.N. Yiagos, Supervised by J.H. Prevost, 6/20/90, (PB91-110197, A13, MF-A02).
- NCEER-90-0013 "Secondary Systems in Base-Isolated Structures: Experimental Investigation, Stochastic Response and Stochastic Sensitivity," by G.D. Manolis, G. Juhn, M.C. Constantinou and A.M. Reinhorn, 7/1/90, (PB91-110320, A08, MF-A01).
- NCEER-90-0014 "Seismic Behavior of Lightly-Reinforced Concrete Column and Beam-Column Joint Details," by S.P. Pessiki, C.H. Conley, P. Gergely and R.N. White, 8/22/90, (PB91-108795, A11, MF-A02).
- NCEER-90-0015 "Two Hybrid Control Systems for Building Structures Under Strong Earthquakes," by J.N. Yang and A. Danielians, 6/29/90, (PB91-125393, A04, MF-A01).
- NCEER-90-0016 "Instantaneous Optimal Control with Acceleration and Velocity Feedback," by J.N. Yang and Z. Li, 6/29/90, (PB91-125401, A03, MF-A01).
- NCEER-90-0017 "Reconnaissance Report on the Northern Iran Earthquake of June 21, 1990," by M. Mehrain, 10/4/90, (PB91-125377, A03, MF-A01).
- NCEER-90-0018 "Evaluation of Liquefaction Potential in Memphis and Shelby County," by T.S. Chang, P.S. Tang, C.S. Lee and H. Hwang, 8/10/90, (PB91-125427, A09, MF-A01).
- NCEER-90-0019 "Experimental and Analytical Study of a Combined Sliding Disc Bearing and Helical Steel Spring Isolation System," by M.C. Constantinou, A.S. Mokha and A.M. Reinhorn, 10/4/90, (PB91-125385, A06, MF-A01). This report is available only through NTIS (see address given above).
- NCEER-90-0020 "Experimental Study and Analytical Prediction of Earthquake Response of a Sliding Isolation System with a Spherical Surface," by A.S. Mokha, M.C. Constantinou and A.M. Reinhorn, 10/11/90, (PB91-125419, A05, MF-A01).
- NCEER-90-0021 "Dynamic Interaction Factors for Floating Pile Groups," by G. Gazetas, K. Fan, A. Kaynia and E. Kausel, 9/10/90, (PB91-170381, A05, MF-A01).
- NCEER-90-0022 "Evaluation of Seismic Damage Indices for Reinforced Concrete Structures," by S. Rodriguez-Gomez and A.S. Cakmak, 9/30/90, PB91-171322, A06, MF-A01).
- NCEER-90-0023 "Study of Site Response at a Selected Memphis Site," by H. Desai, S. Ahmad, E.S. Gazetas and M.R. Oh, 10/11/90, (PB91-196857, A03, MF-A01).
- NCEER-90-0024 "A User's Guide to Strongmo: Version 1.0 of NCEER's Strong-Motion Data Access Tool for PCs and Terminals," by P.A. Friberg and C.A.T. Susch, 11/15/90, (PB91-171272, A03, MF-A01).
- NCEER-90-0025 "A Three-Dimensional Analytical Study of Spatial Variability of Seismic Ground Motions," by L-L. Hong and A.H.-S. Ang, 10/30/90, (PB91-170399, A09, MF-A01).
- NCEER-90-0026 "MUMOID User's Guide - A Program for the Identification of Modal Parameters," by S. Rodriguez-Gomez and E. DiPasquale, 9/30/90, (PB91-171298, A04, MF-A01).
- NCEER-90-0027 "SARCF-II User's Guide - Seismic Analysis of Reinforced Concrete Frames," by S. Rodriguez-Gomez, Y.S. Chung and C. Meyer, 9/30/90, (PB91-171280, A05, MF-A01).
- NCEER-90-0028 "Viscous Dampers: Testing, Modeling and Application in Vibration and Seismic Isolation," by N. Makris and M.C. Constantinou, 12/20/90 (PB91-190561, A06, MF-A01).
- NCEER-90-0029 "Soil Effects on Earthquake Ground Motions in the Memphis Area," by H. Hwang, C.S. Lee, K.W. Ng and T.S. Chang, 8/2/90, (PB91-190751, A05, MF-A01).

- NCEER-91-0001 "Proceedings from the Third Japan-U.S. Workshop on Earthquake Resistant Design of Lifeline Facilities and Countermeasures for Soil Liquefaction, December 17-19, 1990," edited by T.D. O'Rourke and M. Hamada, 2/1/91, (PB91-179259, A99, MF-A04).
- NCEER-91-0002 "Physical Space Solutions of Non-Proportionally Damped Systems," by M. Tong, Z. Liang and G.C. Lee, 1/15/91, (PB91-179242, A04, MF-A01).
- NCEER-91-0003 "Seismic Response of Single Piles and Pile Groups," by K. Fan and G. Gazetas, 1/10/91, (PB92-174994, A04, MF-A01).
- NCEER-91-0004 "Damping of Structures: Part 1 - Theory of Complex Damping," by Z. Liang and G. Lee, 10/10/91, (PB92-197235, A12, MF-A03).
- NCEER-91-0005 "3D-BASIS - Nonlinear Dynamic Analysis of Three Dimensional Base Isolated Structures: Part II," by S. Nagarajaiah, A.M. Reinhorn and M.C. Constantinou, 2/28/91, (PB91-190553, A07, MF-A01). This report has been replaced by NCEER-93-0011.
- NCEER-91-0006 "A Multidimensional Hysteretic Model for Plasticity Deforming Metals in Energy Absorbing Devices," by E.J. Graesser and F.A. Cozzarelli, 4/9/91, (PB92-108364, A04, MF-A01).
- NCEER-91-0007 "A Framework for Customizable Knowledge-Based Expert Systems with an Application to a KBES for Evaluating the Seismic Resistance of Existing Buildings," by E.G. Ibarra-Anaya and S.J. Fenves, 4/9/91, (PB91-210930, A08, MF-A01).
- NCEER-91-0008 "Nonlinear Analysis of Steel Frames with Semi-Rigid Connections Using the Capacity Spectrum Method," by G.G. Deierlein, S-H. Hsieh, Y-J. Shen and J.F. Abel, 7/2/91, (PB92-113828, A05, MF-A01).
- NCEER-91-0009 "Earthquake Education Materials for Grades K-12," by K.E.K. Ross, 4/30/91, (PB91-212142, A06, MF-A01). This report has been replaced by NCEER-92-0018.
- NCEER-91-0010 "Phase Wave Velocities and Displacement Phase Differences in a Harmonically Oscillating Pile," by N. Makris and G. Gazetas, 7/8/91, (PB92-108356, A04, MF-A01).
- NCEER-91-0011 "Dynamic Characteristics of a Full-Size Five-Story Steel Structure and a 2/5 Scale Model," by K.C. Chang, G.C. Yao, G.C. Lee, D.S. Hao and Y.C. Yeh," 7/2/91, (PB93-116648, A06, MF-A02).
- NCEER-91-0012 "Seismic Response of a 2/5 Scale Steel Structure with Added Viscoelastic Dampers," by K.C. Chang, T.T. Soong, S-T. Oh and M.L. Lai, 5/17/91, (PB92-110816, A05, MF-A01).
- NCEER-91-0013 "Earthquake Response of Retaining Walls; Full-Scale Testing and Computational Modeling," by S. Alampalli and A-W.M. Elgamal, 6/20/91, to be published.
- NCEER-91-0014 "3D-BASIS-M: Nonlinear Dynamic Analysis of Multiple Building Base Isolated Structures," by P.C. Tsopelas, S. Nagarajaiah, M.C. Constantinou and A.M. Reinhorn, 5/28/91, (PB92-113885, A09, MF-A02).
- NCEER-91-0015 "Evaluation of SEAOC Design Requirements for Sliding Isolated Structures," by D. Theodossiou and M.C. Constantinou, 6/10/91, (PB92-114602, A11, MF-A03).
- NCEER-91-0016 "Closed-Loop Modal Testing of a 27-Story Reinforced Concrete Flat Plate-Core Building," by H.R. Somaprasad, T. Toksoy, H. Yoshiyuki and A.E. Aktan, 7/15/91, (PB92-129980, A07, MF-A02).
- NCEER-91-0017 "Shake Table Test of a 1/6 Scale Two-Story Lightly Reinforced Concrete Building," by A.G. El-Attar, R.N. White and P. Gergely, 2/28/91, (PB92-222447, A06, MF-A02).
- NCEER-91-0018 "Shake Table Test of a 1/8 Scale Three-Story Lightly Reinforced Concrete Building," by A.G. El-Attar, R.N. White and P. Gergely, 2/28/91, (PB93-116630, A08, MF-A02).
- NCEER-91-0019 "Transfer Functions for Rigid Rectangular Foundations," by A.S. Veletsos, A.M. Prasad and W.H. Wu, 7/31/91, to be published.

- NCEER-91-0020 "Hybrid Control of Seismic-Excited Nonlinear and Inelastic Structural Systems," by J.N. Yang, Z. Li and A. Daniellians, 8/1/91, (PB92-143171, A06, MF-A02).
- NCEER-91-0021 "The NCEER-91 Earthquake Catalog: Improved Intensity-Based Magnitudes and Recurrence Relations for U.S. Earthquakes East of New Madrid," by L. Seeber and J.G. Armbruster, 8/28/91, (PB92-176742, A06, MF-A02).
- NCEER-91-0022 "Proceedings from the Implementation of Earthquake Planning and Education in Schools: The Need for Change - The Roles of the Changemakers," by K.E.K. Ross and F. Winslow, 7/23/91, (PB92-129998, A12, MF-A03).
- NCEER-91-0023 "A Study of Reliability-Based Criteria for Seismic Design of Reinforced Concrete Frame Buildings," by H.H.M. Hwang and H-M. Hsu, 8/10/91, (PB92-140235, A09, MF-A02).
- NCEER-91-0024 "Experimental Verification of a Number of Structural System Identification Algorithms," by R.G. Ghanem, H. Gavin and M. Shinozuka, 9/18/91, (PB92-176577, A18, MF-A04).
- NCEER-91-0025 "Probabilistic Evaluation of Liquefaction Potential," by H.H.M. Hwang and C.S. Lee," 11/25/91, (PB92-143429, A05, MF-A01).
- NCEER-91-0026 "Instantaneous Optimal Control for Linear, Nonlinear and Hysteretic Structures - Stable Controllers," by J.N. Yang and Z. Li, 11/15/91, (PB92-163807, A04, MF-A01).
- NCEER-91-0027 "Experimental and Theoretical Study of a Sliding Isolation System for Bridges," by M.C. Constantinou, A. Kartoum, A.M. Reinhorn and P. Bradford, 11/15/91, (PB92-176973, A10, MF-A03).
- NCEER-92-0001 "Case Studies of Liquefaction and Lifeline Performance During Past Earthquakes, Volume 1: Japanese Case Studies," Edited by M. Hamada and T. O'Rourke, 2/17/92, (PB92-197243, A18, MF-A04).
- NCEER-92-0002 "Case Studies of Liquefaction and Lifeline Performance During Past Earthquakes, Volume 2: United States Case Studies," Edited by T. O'Rourke and M. Hamada, 2/17/92, (PB92-197250, A20, MF-A04).
- NCEER-92-0003 "Issues in Earthquake Education," Edited by K. Ross, 2/3/92, (PB92-222389, A07, MF-A02).
- NCEER-92-0004 "Proceedings from the First U.S. - Japan Workshop on Earthquake Protective Systems for Bridges," Edited by I.G. Buckle, 2/4/92, (PB94-142239, A99, MF-A06).
- NCEER-92-0005 "Seismic Ground Motion from a Haskell-Type Source in a Multiple-Layered Half-Space," A.P. Theoharis, G. Deodatis and M. Shinozuka, 1/2/92, to be published.
- NCEER-92-0006 "Proceedings from the Site Effects Workshop," Edited by R. Whitman, 2/29/92, (PB92-197201, A04, MF-A01).
- NCEER-92-0007 "Engineering Evaluation of Permanent Ground Deformations Due to Seismically-Induced Liquefaction," by M.H. Baziar, R. Dobry and A-W.M. Elgamel, 3/24/92, (PB92-222421, A13, MF-A03).
- NCEER-92-0008 "A Procedure for the Seismic Evaluation of Buildings in the Central and Eastern United States," by C.D. Poland and J.O. Malley, 4/2/92, (PB92-222439, A20, MF-A04).
- NCEER-92-0009 "Experimental and Analytical Study of a Hybrid Isolation System Using Friction Controllable Sliding Bearings," by M.Q. Feng, S. Fujii and M. Shinozuka, 5/15/92, (PB93-150282, A06, MF-A02).
- NCEER-92-0010 "Seismic Resistance of Slab-Column Connections in Existing Non-Ductile Flat-Plate Buildings," by A.J. Durrani and Y. Du, 5/18/92, (PB93-116812, A06, MF-A02).
- NCEER-92-0011 "The Hysteretic and Dynamic Behavior of Brick Masonry Walls Upgraded by Ferrocement Coatings Under Cyclic Loading and Strong Simulated Ground Motion," by H. Lee and S.P. Prawel, 5/11/92, to be published.
- NCEER-92-0012 "Study of Wire Rope Systems for Seismic Protection of Equipment in Buildings," by G.F. Demetriades, M.C. Constantinou and A.M. Reinhorn, 5/20/92, (PB93-116655, A08, MF-A02).

- NCEER-92-0013 "Shape Memory Structural Dampers: Material Properties, Design and Seismic Testing," by P.R. Witting and F.A. Cozzarelli, 5/26/92, (PB93-116663, A05, MF-A01).
- NCEER-92-0014 "Longitudinal Permanent Ground Deformation Effects on Buried Continuous Pipelines," by M.J. O'Rourke, and C. Nordberg, 6/15/92, (PB93-116671, A08, MF-A02).
- NCEER-92-0015 "A Simulation Method for Stationary Gaussian Random Functions Based on the Sampling Theorem," by M. Grigoriu and S. Balopoulou, 6/11/92, (PB93-127496, A05, MF-A01).
- NCEER-92-0016 "Gravity-Load-Designed Reinforced Concrete Buildings: Seismic Evaluation of Existing Construction and Detailing Strategies for Improved Seismic Resistance," by G.W. Hoffmann, S.K. Kunnath, A.M. Reinhorn and J.B. Mander, 7/15/92, (PB94-142007, A08, MF-A02).
- NCEER-92-0017 "Observations on Water System and Pipeline Performance in the Limón Area of Costa Rica Due to the April 22, 1991 Earthquake," by M. O'Rourke and D. Ballantyne, 6/30/92, (PB93-126811, A06, MF-A02).
- NCEER-92-0018 "Fourth Edition of Earthquake Education Materials for Grades K-12," Edited by K.E.K. Ross, 8/10/92, (PB93-114023, A07, MF-A02).
- NCEER-92-0019 "Proceedings from the Fourth Japan-U.S. Workshop on Earthquake Resistant Design of Lifeline Facilities and Countermeasures for Soil Liquefaction," Edited by M. Hamada and T.D. O'Rourke, 8/12/92, (PB93-163939, A99, MF-E11).
- NCEER-92-0020 "Active Bracing System: A Full Scale Implementation of Active Control," by A.M. Reinhorn, T.T. Soong, R.C. Lin, M.A. Riley, Y.P. Wang, S. Aizawa and M. Higashino, 8/14/92, (PB93-127512, A06, MF-A02).
- NCEER-92-0021 "Empirical Analysis of Horizontal Ground Displacement Generated by Liquefaction-Induced Lateral Spreads," by S.F. Bartlett and T.L. Youd, 8/17/92, (PB93-188241, A06, MF-A02).
- NCEER-92-0022 "IDARC Version 3.0: Inelastic Damage Analysis of Reinforced Concrete Structures," by S.K. Kunnath, A.M. Reinhorn and R.F. Lobo, 8/31/92, (PB93-227502, A07, MF-A02).
- NCEER-92-0023 "A Semi-Empirical Analysis of Strong-Motion Peaks in Terms of Seismic Source, Propagation Path and Local Site Conditions, by M. Kamiyama, M.J. O'Rourke and R. Flores-Berrones, 9/9/92, (PB93-150266, A08, MF-A02).
- NCEER-92-0024 "Seismic Behavior of Reinforced Concrete Frame Structures with Nonductile Details, Part I: Summary of Experimental Findings of Full Scale Beam-Column Joint Tests," by A. Beres, R.N. White and P. Gergely, 9/30/92, (PB93-227783, A05, MF-A01).
- NCEER-92-0025 "Experimental Results of Repaired and Retrofitted Beam-Column Joint Tests in Lightly Reinforced Concrete Frame Buildings," by A. Beres, S. El-Borgi, R.N. White and P. Gergely, 10/29/92, (PB93-227791, A05, MF-A01).
- NCEER-92-0026 "A Generalization of Optimal Control Theory: Linear and Nonlinear Structures," by J.N. Yang, Z. Li and S. Vongchavalitkul, 11/2/92, (PB93-188621, A05, MF-A01).
- NCEER-92-0027 "Seismic Resistance of Reinforced Concrete Frame Structures Designed Only for Gravity Loads: Part I - Design and Properties of a One-Third Scale Model Structure," by J.M. Bracci, A.M. Reinhorn and J.B. Mander, 12/1/92, (PB94-104502, A08, MF-A02).
- NCEER-92-0028 "Seismic Resistance of Reinforced Concrete Frame Structures Designed Only for Gravity Loads: Part II - Experimental Performance of Subassemblages," by L.E. Aycaardi, J.B. Mander and A.M. Reinhorn, 12/1/92, (PB94-104510, A08, MF-A02).
- NCEER-92-0029 "Seismic Resistance of Reinforced Concrete Frame Structures Designed Only for Gravity Loads: Part III - Experimental Performance and Analytical Study of a Structural Model," by J.M. Bracci, A.M. Reinhorn and J.B. Mander, 12/1/92, (PB93-227528, A09, MF-A01).

- NCEER-92-0030 "Evaluation of Seismic Retrofit of Reinforced Concrete Frame Structures: Part I - Experimental Performance of Retrofitted Subassemblages," by D. Choudhuri, J.B. Mander and A.M. Reinhorn, 12/8/92, (PB93-198307, A07, MF-A02).
- NCEER-92-0031 "Evaluation of Seismic Retrofit of Reinforced Concrete Frame Structures: Part II - Experimental Performance and Analytical Study of a Retrofitted Structural Model," by J.M. Bracci, A.M. Reinhorn and J.B. Mander, 12/8/92, (PB93-198315, A09, MF-A03).
- NCEER-92-0032 "Experimental and Analytical Investigation of Seismic Response of Structures with Supplemental Fluid Viscous Dampers," by M.C. Constantinou and M.D. Symans, 12/21/92, (PB93-191435, A10, MF-A03). This report is available only through NTIS (see address given above).
- NCEER-92-0033 "Reconnaissance Report on the Cairo, Egypt Earthquake of October 12, 1992," by M. Khater, 12/23/92, (PB93-188621, A03, MF-A01).
- NCEER-92-0034 "Low-Level Dynamic Characteristics of Four Tall Flat-Plate Buildings in New York City," by H. Gavin, S. Yuan, J. Grossman, E. Pekelis and K. Jacob, 12/28/92, (PB93-188217, A07, MF-A02).
- NCEER-93-0001 "An Experimental Study on the Seismic Performance of Brick-Infilled Steel Frames With and Without Retrofit," by J.B. Mander, B. Nair, K. Wojtkowski and J. Ma, 1/29/93, (PB93-227510, A07, MF-A02).
- NCEER-93-0002 "Social Accounting for Disaster Preparedness and Recovery Planning," by S. Cole, E. Pantoja and V. Razak, 2/22/93, (PB94-142114, A12, MF-A03).
- NCEER-93-0003 "Assessment of 1991 NEHRP Provisions for Nonstructural Components and Recommended Revisions," by T.T. Soong, G. Chen, Z. Wu, R-H. Zhang and M. Grigoriu, 3/1/93, (PB93-188639, A06, MF-A02).
- NCEER-93-0004 "Evaluation of Static and Response Spectrum Analysis Procedures of SEAOC/UBC for Seismic Isolated Structures," by C.W. Winters and M.C. Constantinou, 3/23/93, (PB93-198299, A10, MF-A03).
- NCEER-93-0005 "Earthquakes in the Northeast - Are We Ignoring the Hazard? A Workshop on Earthquake Science and Safety for Educators," edited by K.E.K. Ross, 4/2/93, (PB94-103066, A09, MF-A02).
- NCEER-93-0006 "Inelastic Response of Reinforced Concrete Structures with Viscoelastic Braces," by R.F. Lobo, J.M. Bracci, K.L. Shen, A.M. Reinhorn and T.T. Soong, 4/5/93, (PB93-227486, A05, MF-A02).
- NCEER-93-0007 "Seismic Testing of Installation Methods for Computers and Data Processing Equipment," by K. Kosar, T.T. Soong, K.L. Shen, J.A. HoLung and Y.K. Lin, 4/12/93, (PB93-198299, A07, MF-A02).
- NCEER-93-0008 "Retrofit of Reinforced Concrete Frames Using Added Dampers," by A. Reinhorn, M. Constantinou and C. Li, to be published.
- NCEER-93-0009 "Seismic Behavior and Design Guidelines for Steel Frame Structures with Added Viscoelastic Dampers," by K.C. Chang, M.L. Lai, T.T. Soong, D.S. Hao and Y.C. Yeh, 5/1/93, (PB94-141959, A07, MF-A02).
- NCEER-93-0010 "Seismic Performance of Shear-Critical Reinforced Concrete Bridge Piers," by J.B. Mander, S.M. Waheed, M.T.A. Chaudhary and S.S. Chen, 5/12/93, (PB93-227494, A08, MF-A02).
- NCEER-93-0011 "3D-BASIS-TABS: Computer Program for Nonlinear Dynamic Analysis of Three Dimensional Base Isolated Structures," by S. Nagarajaiah, C. Li, A.M. Reinhorn and M.C. Constantinou, 8/2/93, (PB94-141819, A09, MF-A02).
- NCEER-93-0012 "Effects of Hydrocarbon Spills from an Oil Pipeline Break on Ground Water," by O.J. Helweg and H.H.M. Hwang, 8/3/93, (PB94-141942, A06, MF-A02).
- NCEER-93-0013 "Simplified Procedures for Seismic Design of Nonstructural Components and Assessment of Current Code Provisions," by M.P. Singh, L.E. Suarez, E.E. Matheu and G.O. Maldonado, 8/4/93, (PB94-141827, A09, MF-A02).
- NCEER-93-0014 "An Energy Approach to Seismic Analysis and Design of Secondary Systems," by G. Chen and T.T. Soong, 8/6/93, (PB94-142767, A11, MF-A03).



- NCEER-93-0015 "Proceedings from School Sites: Becoming Prepared for Earthquakes - Commemorating the Third Anniversary of the Loma Prieta Earthquake," Edited by F.E. Winslow and K.E.K. Ross, 8/16/93, (PB94-154275, A16, MF-A02).
- NCEER-93-0016 "Reconnaissance Report of Damage to Historic Monuments in Cairo, Egypt Following the October 12, 1992 Dahshur Earthquake," by D. Sykora, D. Look, G. Croci, E. Karaesmen and E. Karaesmen, 8/19/93, (PB94-142221, A08, MF-A02).
- NCEER-93-0017 "The Island of Guam Earthquake of August 8, 1993," by S.W. Swan and S.K. Harris, 9/30/93, (PB94-141843, A04, MF-A01).
- NCEER-93-0018 "Engineering Aspects of the October 12, 1992 Egyptian Earthquake," by A.W. Elgamal, M. Amer, K. Adalier and A. Abul-Fadl, 10/7/93, (PB94-141983, A05, MF-A01).
- NCEER-93-0019 "Development of an Earthquake Motion Simulator and its Application in Dynamic Centrifuge Testing," by I. Krstelj, Supervised by J.H. Prevost, 10/23/93, (PB94-181773, A-10, MF-A03).
- NCEER-93-0020 "NCEER-Taisei Corporation Research Program on Sliding Seismic Isolation Systems for Bridges: Experimental and Analytical Study of a Friction Pendulum System (FPS)," by M.C. Constantinou, P. Tsopelas, Y-S. Kim and S. Okamoto, 11/1/93, (PB94-142775, A08, MF-A02).
- NCEER-93-0021 "Finite Element Modeling of Elastomeric Seismic Isolation Bearings," by L.J. Billings, Supervised by R. Shepherd, 11/8/93, to be published.
- NCEER-93-0022 "Seismic Vulnerability of Equipment in Critical Facilities: Life-Safety and Operational Consequences," by K. Porter, G.S. Johnson, M.M. Zadeh, C. Scawthorn and S. Eder, 11/24/93, (PB94-181765, A16, MF-A03).
- NCEER-93-0023 "Hokkaido Nansei-oki, Japan Earthquake of July 12, 1993, by P.I. Yanev and C.R. Scawthorn, 12/23/93, (PB94-181500, A07, MF-A01).
- NCEER-94-0001 "An Evaluation of Seismic Serviceability of Water Supply Networks with Application to the San Francisco Auxiliary Water Supply System," by I. Markov, Supervised by M. Grigoriu and T. O'Rourke, 1/21/94, (PB94-204013, A07, MF-A02).
- NCEER-94-0002 "NCEER-Taisei Corporation Research Program on Sliding Seismic Isolation Systems for Bridges: Experimental and Analytical Study of Systems Consisting of Sliding Bearings, Rubber Restoring Force Devices and Fluid Dampers," Volumes I and II, by P. Tsopelas, S. Okamoto, M.C. Constantinou, D. Ozaki and S. Fujii, 2/4/94, (PB94-181740, A09, MF-A02 and PB94-181757, A12, MF-A03).
- NCEER-94-0003 "A Markov Model for Local and Global Damage Indices in Seismic Analysis," by S. Rahman and M. Grigoriu, 2/18/94, (PB94-206000, A12, MF-A03).
- NCEER-94-0004 "Proceedings from the NCEER Workshop on Seismic Response of Masonry Infills," edited by D.P. Abrams, 3/1/94, (PB94-180783, A07, MF-A02).
- NCEER-94-0005 "The Northridge, California Earthquake of January 17, 1994: General Reconnaissance Report," edited by J.D. Goltz, 3/11/94, (PB193943, A10, MF-A03).
- NCEER-94-0006 "Seismic Energy Based Fatigue Damage Analysis of Bridge Columns: Part I - Evaluation of Seismic Capacity," by G.A. Chang and J.B. Mander, 3/14/94, (PB94-219185, A11, MF-A03).
- NCEER-94-0007 "Seismic Isolation of Multi-Story Frame Structures Using Spherical Sliding Isolation Systems," by T.M. Al-Hussaini, V.A. Zayas and M.C. Constantinou, 3/17/94, (PB193745, A09, MF-A02).
- NCEER-94-0008 "The Northridge, California Earthquake of January 17, 1994: Performance of Highway Bridges," edited by I.G. Buckle, 3/24/94, (PB94-193851, A06, MF-A02).
- NCEER-94-0009 "Proceedings of the Third U.S.-Japan Workshop on Earthquake Protective Systems for Bridges," edited by I.G. Buckle and I. Friedland, 3/31/94, (PB94-195815, A99, MF-A06).

- NCEER-94-0010 "3D-BASIS-ME: Computer Program for Nonlinear Dynamic Analysis of Seismically Isolated Single and Multiple Structures and Liquid Storage Tanks," by P.C. Tsopelas, M.C. Constantinou and A.M. Reinhorn, 4/12/94, (PB94-204922, A09, MF-A02).
- NCEER-94-0011 "The Northridge, California Earthquake of January 17, 1994: Performance of Gas Transmission Pipelines," by T.D. O'Rourke and M.C. Palmer, 5/16/94, (PB94-204989, A05, MF-A01).
- NCEER-94-0012 "Feasibility Study of Replacement Procedures and Earthquake Performance Related to Gas Transmission Pipelines," by T.D. O'Rourke and M.C. Palmer, 5/25/94, (PB94-206638, A09, MF-A02).
- NCEER-94-0013 "Seismic Energy Based Fatigue Damage Analysis of Bridge Columns: Part II - Evaluation of Seismic Demand," by G.A. Chang and J.B. Mander, 6/1/94, (PB95-18106, A08, MF-A02).
- NCEER-94-0014 "NCEER-Taisei Corporation Research Program on Sliding Seismic Isolation Systems for Bridges: Experimental and Analytical Study of a System Consisting of Sliding Bearings and Fluid Restoring Force/Damping Devices," by P. Tsopelas and M.C. Constantinou, 6/13/94, (PB94-219144, A10, MF-A03).
- NCEER-94-0015 "Generation of Hazard-Consistent Fragility Curves for Seismic Loss Estimation Studies," by H. Hwang and J-R. Huo, 6/14/94, (PB95-181996, A09, MF-A02).
- NCEER-94-0016 "Seismic Study of Building Frames with Added Energy-Absorbing Devices," by W.S. Pong, C.S. Tsai and G.C. Lee, 6/20/94, (PB94-219136, A10, A03).
- NCEER-94-0017 "Sliding Mode Control for Seismic-Excited Linear and Nonlinear Civil Engineering Structures," by J. Yang, J. Wu, A. Agrawal and Z. Li, 6/21/94, (PB95-138483, A06, MF-A02).
- NCEER-94-0018 "3D-BASIS-TABS Version 2.0: Computer Program for Nonlinear Dynamic Analysis of Three Dimensional Base Isolated Structures," by A.M. Reinhorn, S. Nagarajaiah, M.C. Constantinou, P. Tsopelas and R. Li, 6/22/94, (PB95-182176, A08, MF-A02).
- NCEER-94-0019 "Proceedings of the International Workshop on Civil Infrastructure Systems: Application of Intelligent Systems and Advanced Materials on Bridge Systems," Edited by G.C. Lee and K.C. Chang, 7/18/94, (PB95-252474, A20, MF-A04).
- NCEER-94-0020 "Study of Seismic Isolation Systems for Computer Floors," by V. Lambrou and M.C. Constantinou, 7/19/94, (PB95-138533, A10, MF-A03).
- NCEER-94-0021 "Proceedings of the U.S.-Italian Workshop on Guidelines for Seismic Evaluation and Rehabilitation of Unreinforced Masonry Buildings," Edited by D.P. Abrams and G.M. Calvi, 7/20/94, (PB95-138749, A13, MF-A03).
- NCEER-94-0022 "NCEER-Taisei Corporation Research Program on Sliding Seismic Isolation Systems for Bridges: Experimental and Analytical Study of a System Consisting of Lubricated PTFE Sliding Bearings and Mild Steel Dampers," by P. Tsopelas and M.C. Constantinou, 7/22/94, (PB95-182184, A08, MF-A02).
- NCEER-94-0023 "Development of Reliability-Based Design Criteria for Buildings Under Seismic Load," by Y.K. Wen, H. Hwang and M. Shinozuka, 8/1/94, (PB95-211934, A08, MF-A02).
- NCEER-94-0024 "Experimental Verification of Acceleration Feedback Control Strategies for an Active Tendon System," by S.J. Dyke, B.F. Spencer, Jr., P. Quast, M.K. Sain, D.C. Kaspari, Jr. and T.T. Soong, 8/29/94, (PB95-212320, A05, MF-A01).
- NCEER-94-0025 "Seismic Retrofitting Manual for Highway Bridges," Edited by I.G. Buckle and I.F. Friedland, published by the Federal Highway Administration (PB95-212676, A15, MF-A03).
- NCEER-94-0026 "Proceedings from the Fifth U.S.-Japan Workshop on Earthquake Resistant Design of Lifeline Facilities and Countermeasures Against Soil Liquefaction," Edited by T.D. O'Rourke and M. Hamada, 11/7/94, (PB95-220802, A99, MF-E08).

- NCEER-95-0001 “Experimental and Analytical Investigation of Seismic Retrofit of Structures with Supplemental Damping: Part 1 - Fluid Viscous Damping Devices,” by A.M. Reinhorn, C. Li and M.C. Constantinou, 1/3/95, (PB95-266599, A09, MF-A02).
- NCEER-95-0002 “Experimental and Analytical Study of Low-Cycle Fatigue Behavior of Semi-Rigid Top-And-Seat Angle Connections,” by G. Pekcan, J.B. Mander and S.S. Chen, 1/5/95, (PB95-220042, A07, MF-A02).
- NCEER-95-0003 “NCEER-ATC Joint Study on Fragility of Buildings,” by T. Anagnos, C. Rojahn and A.S. Kiremidjian, 1/20/95, (PB95-220026, A06, MF-A02).
- NCEER-95-0004 “Nonlinear Control Algorithms for Peak Response Reduction,” by Z. Wu, T.T. Soong, V. Gattulli and R.C. Lin, 2/16/95, (PB95-220349, A05, MF-A01).
- NCEER-95-0005 “Pipeline Replacement Feasibility Study: A Methodology for Minimizing Seismic and Corrosion Risks to Underground Natural Gas Pipelines,” by R.T. Eguchi, H.A. Seligson and D.G. Honegger, 3/2/95, (PB95-252326, A06, MF-A02).
- NCEER-95-0006 “Evaluation of Seismic Performance of an 11-Story Frame Building During the 1994 Northridge Earthquake,” by F. Naeim, R. DiSulio, K. Benuska, A. Reinhorn and C. Li, to be published.
- NCEER-95-0007 “Prioritization of Bridges for Seismic Retrofitting,” by N. Basöz and A.S. Kiremidjian, 4/24/95, (PB95-252300, A08, MF-A02).
- NCEER-95-0008 “Method for Developing Motion Damage Relationships for Reinforced Concrete Frames,” by A. Singhal and A.S. Kiremidjian, 5/11/95, (PB95-266607, A06, MF-A02).
- NCEER-95-0009 “Experimental and Analytical Investigation of Seismic Retrofit of Structures with Supplemental Damping: Part II - Friction Devices,” by C. Li and A.M. Reinhorn, 7/6/95, (PB96-128087, A11, MF-A03).
- NCEER-95-0010 “Experimental Performance and Analytical Study of a Non-Ductile Reinforced Concrete Frame Structure Retrofitted with Elastomeric Spring Dampers,” by G. Pekcan, J.B. Mander and S.S. Chen, 7/14/95, (PB96-137161, A08, MF-A02).
- NCEER-95-0011 “Development and Experimental Study of Semi-Active Fluid Damping Devices for Seismic Protection of Structures,” by M.D. Symans and M.C. Constantinou, 8/3/95, (PB96-136940, A23, MF-A04).
- NCEER-95-0012 “Real-Time Structural Parameter Modification (RSPM): Development of Innervated Structures,” by Z. Liang, M. Tong and G.C. Lee, 4/11/95, (PB96-137153, A06, MF-A01).
- NCEER-95-0013 “Experimental and Analytical Investigation of Seismic Retrofit of Structures with Supplemental Damping: Part III - Viscous Damping Walls,” by A.M. Reinhorn and C. Li, 10/1/95, (PB96-176409, A11, MF-A03).
- NCEER-95-0014 “Seismic Fragility Analysis of Equipment and Structures in a Memphis Electric Substation,” by J-R. Huo and H.H.M. Hwang, (PB96-128087, A09, MF-A02), 8/10/95.
- NCEER-95-0015 “The Hanshin-Awaji Earthquake of January 17, 1995: Performance of Lifelines,” Edited by M. Shinozuka, 11/3/95, (PB96-176383, A15, MF-A03).
- NCEER-95-0016 “Highway Culvert Performance During Earthquakes,” by T.L. Youd and C.J. Beckman, available as NCEER-96-0015.
- NCEER-95-0017 “The Hanshin-Awaji Earthquake of January 17, 1995: Performance of Highway Bridges,” Edited by I.G. Buckle, 12/1/95, to be published.
- NCEER-95-0018 “Modeling of Masonry Infill Panels for Structural Analysis,” by A.M. Reinhorn, A. Madan, R.E. Valles, Y. Reichmann and J.B. Mander, 12/8/95, (PB97-110886, MF-A01, A06).
- NCEER-95-0019 “Optimal Polynomial Control for Linear and Nonlinear Structures,” by A.K. Agrawal and J.N. Yang, 12/11/95, (PB96-168737, A07, MF-A02).

- NCEER-95-0020 "Retrofit of Non-Ductile Reinforced Concrete Frames Using Friction Dampers," by R.S. Rao, P. Gergely and R.N. White, 12/22/95, (PB97-133508, A10, MF-A02).
- NCEER-95-0021 "Parametric Results for Seismic Response of Pile-Supported Bridge Bents," by G. Mylonakis, A. Nikolaou and G. Gazetas, 12/22/95, (PB97-100242, A12, MF-A03).
- NCEER-95-0022 "Kinematic Bending Moments in Seismically Stressed Piles," by A. Nikolaou, G. Mylonakis and G. Gazetas, 12/23/95, (PB97-113914, MF-A03, A13).
- NCEER-96-0001 "Dynamic Response of Unreinforced Masonry Buildings with Flexible Diaphragms," by A.C. Costley and D.P. Abrams, 10/10/96, (PB97-133573, MF-A03, A15).
- NCEER-96-0002 "State of the Art Review: Foundations and Retaining Structures," by I. Po Lam, to be published.
- NCEER-96-0003 "Ductility of Rectangular Reinforced Concrete Bridge Columns with Moderate Confinement," by N. Wehbe, M. Saiidi, D. Sanders and B. Douglas, 11/7/96, (PB97-133557, A06, MF-A02).
- NCEER-96-0004 "Proceedings of the Long-Span Bridge Seismic Research Workshop," edited by I.G. Buckle and I.M. Friedland, to be published.
- NCEER-96-0005 "Establish Representative Pier Types for Comprehensive Study: Eastern United States," by J. Kulicki and Z. Prucz, 5/28/96, (PB98-119217, A07, MF-A02).
- NCEER-96-0006 "Establish Representative Pier Types for Comprehensive Study: Western United States," by R. Imbsen, R.A. Schamber and T.A. Osterkamp, 5/28/96, (PB98-118607, A07, MF-A02).
- NCEER-96-0007 "Nonlinear Control Techniques for Dynamical Systems with Uncertain Parameters," by R.G. Ghanem and M.I. Bujakov, 5/27/96, (PB97-100259, A17, MF-A03).
- NCEER-96-0008 "Seismic Evaluation of a 30-Year Old Non-Ductile Highway Bridge Pier and Its Retrofit," by J.B. Mander, B. Mahmoodzadegan, S. Bhadra and S.S. Chen, 5/31/96, (PB97-110902, MF-A03, A10).
- NCEER-96-0009 "Seismic Performance of a Model Reinforced Concrete Bridge Pier Before and After Retrofit," by J.B. Mander, J.H. Kim and C.A. Ligozio, 5/31/96, (PB97-110910, MF-A02, A10).
- NCEER-96-0010 "IDARC2D Version 4.0: A Computer Program for the Inelastic Damage Analysis of Buildings," by R.E. Valles, A.M. Reinhorn, S.K. Kunnath, C. Li and A. Madan, 6/3/96, (PB97-100234, A17, MF-A03).
- NCEER-96-0011 "Estimation of the Economic Impact of Multiple Lifeline Disruption: Memphis Light, Gas and Water Division Case Study," by S.E. Chang, H.A. Seligson and R.T. Eguchi, 8/16/96, (PB97-133490, A11, MF-A03).
- NCEER-96-0012 "Proceedings from the Sixth Japan-U.S. Workshop on Earthquake Resistant Design of Lifeline Facilities and Countermeasures Against Soil Liquefaction, Edited by M. Hamada and T. O'Rourke, 9/11/96, (PB97-133581, A99, MF-A06).
- NCEER-96-0013 "Chemical Hazards, Mitigation and Preparedness in Areas of High Seismic Risk: A Methodology for Estimating the Risk of Post-Earthquake Hazardous Materials Release," by H.A. Seligson, R.T. Eguchi, K.J. Tierney and K. Richmond, 11/7/96, (PB97-133565, MF-A02, A08).
- NCEER-96-0014 "Response of Steel Bridge Bearings to Reversed Cyclic Loading," by J.B. Mander, D-K. Kim, S.S. Chen and G.J. Premus, 11/13/96, (PB97-140735, A12, MF-A03).
- NCEER-96-0015 "Highway Culvert Performance During Past Earthquakes," by T.L. Youd and C.J. Beckman, 11/25/96, (PB97-133532, A06, MF-A01).
- NCEER-97-0001 "Evaluation, Prevention and Mitigation of Pounding Effects in Building Structures," by R.E. Valles and A.M. Reinhorn, 2/20/97, (PB97-159552, A14, MF-A03).
- NCEER-97-0002 "Seismic Design Criteria for Bridges and Other Highway Structures," by C. Rojahn, R. Mayes, D.G. Anderson, J. Clark, J.H. Hom, R.V. Nutt and M.J. O'Rourke, 4/30/97, (PB97-194658, A06, MF-A03).

- NCEER-97-0003 "Proceedings of the U.S.-Italian Workshop on Seismic Evaluation and Retrofit," Edited by D.P. Abrams and G.M. Calvi, 3/19/97, (PB97-194666, A13, MF-A03).
- NCEER-97-0004 "Investigation of Seismic Response of Buildings with Linear and Nonlinear Fluid Viscous Dampers," by A.A. Seleemah and M.C. Constantinou, 5/21/97, (PB98-109002, A15, MF-A03).
- NCEER-97-0005 "Proceedings of the Workshop on Earthquake Engineering Frontiers in Transportation Facilities," edited by G.C. Lee and I.M. Friedland, 8/29/97, (PB98-128911, A25, MR-A04).
- NCEER-97-0006 "Cumulative Seismic Damage of Reinforced Concrete Bridge Piers," by S.K. Kunnath, A. El-Bahy, A. Taylor and W. Stone, 9/2/97, (PB98-108814, A11, MF-A03).
- NCEER-97-0007 "Structural Details to Accommodate Seismic Movements of Highway Bridges and Retaining Walls," by R.A. Imbsen, R.A. Schamber, E. Thorkildsen, A. Kartoum, B.T. Martin, T.N. Rosser and J.M. Kulicki, 9/3/97, (PB98-108996, A09, MF-A02).
- NCEER-97-0008 "A Method for Earthquake Motion-Damage Relationships with Application to Reinforced Concrete Frames," by A. Singhal and A.S. Kiremidjian, 9/10/97, (PB98-108988, A13, MF-A03).
- NCEER-97-0009 "Seismic Analysis and Design of Bridge Abutments Considering Sliding and Rotation," by K. Fishman and R. Richards, Jr., 9/15/97, (PB98-108897, A06, MF-A02).
- NCEER-97-0010 "Proceedings of the FHWA/NCEER Workshop on the National Representation of Seismic Ground Motion for New and Existing Highway Facilities," edited by I.M. Friedland, M.S. Power and R.L. Mayes, 9/22/97, (PB98-128903, A21, MF-A04).
- NCEER-97-0011 "Seismic Analysis for Design or Retrofit of Gravity Bridge Abutments," by K.L. Fishman, R. Richards, Jr. and R.C. Divito, 10/2/97, (PB98-128937, A08, MF-A02).
- NCEER-97-0012 "Evaluation of Simplified Methods of Analysis for Yielding Structures," by P. Tsopelas, M.C. Constantinou, C.A. Kircher and A.S. Whittaker, 10/31/97, (PB98-128929, A10, MF-A03).
- NCEER-97-0013 "Seismic Design of Bridge Columns Based on Control and Repairability of Damage," by C-T. Cheng and J.B. Mander, 12/8/97, (PB98-144249, A11, MF-A03).
- NCEER-97-0014 "Seismic Resistance of Bridge Piers Based on Damage Avoidance Design," by J.B. Mander and C-T. Cheng, 12/10/97, (PB98-144223, A09, MF-A02).
- NCEER-97-0015 "Seismic Response of Nominally Symmetric Systems with Strength Uncertainty," by S. Balopoulou and M. Grigoriu, 12/23/97, (PB98-153422, A11, MF-A03).
- NCEER-97-0016 "Evaluation of Seismic Retrofit Methods for Reinforced Concrete Bridge Columns," by T.J. Wipf, F.W. Klaiber and F.M. Russo, 12/28/97, (PB98-144215, A12, MF-A03).
- NCEER-97-0017 "Seismic Fragility of Existing Conventional Reinforced Concrete Highway Bridges," by C.L. Mullen and A.S. Cakmak, 12/30/97, (PB98-153406, A08, MF-A02).
- NCEER-97-0018 "Loss Assessment of Memphis Buildings," edited by D.P. Abrams and M. Shinozuka, 12/31/97, (PB98-144231, A13, MF-A03).
- NCEER-97-0019 "Seismic Evaluation of Frames with Infill Walls Using Quasi-static Experiments," by K.M. Mosalam, R.N. White and P. Gergely, 12/31/97, (PB98-153455, A07, MF-A02).
- NCEER-97-0020 "Seismic Evaluation of Frames with Infill Walls Using Pseudo-dynamic Experiments," by K.M. Mosalam, R.N. White and P. Gergely, 12/31/97, (PB98-153430, A07, MF-A02).
- NCEER-97-0021 "Computational Strategies for Frames with Infill Walls: Discrete and Smeared Crack Analyses and Seismic Fragility," by K.M. Mosalam, R.N. White and P. Gergely, 12/31/97, (PB98-153414, A10, MF-A02).

- NCEER-97-0022 "Proceedings of the NCEER Workshop on Evaluation of Liquefaction Resistance of Soils," edited by T.L. Youd and I.M. Idriss, 12/31/97, (PB98-155617, A15, MF-A03).
- MCEER-98-0001 "Extraction of Nonlinear Hysteretic Properties of Seismically Isolated Bridges from Quick-Release Field Tests," by Q. Chen, B.M. Douglas, E.M. Maragakis and I.G. Buckle, 5/26/98, (PB99-118838, A06, MF-A01).
- MCEER-98-0002 "Methodologies for Evaluating the Importance of Highway Bridges," by A. Thomas, S. Eshenaur and J. Kulicki, 5/29/98, (PB99-118846, A10, MF-A02).
- MCEER-98-0003 "Capacity Design of Bridge Piers and the Analysis of Overstrength," by J.B. Mander, A. Dutta and P. Goel, 6/1/98, (PB99-118853, A09, MF-A02).
- MCEER-98-0004 "Evaluation of Bridge Damage Data from the Loma Prieta and Northridge, California Earthquakes," by N. Basoz and A. Kiremidjian, 6/2/98, (PB99-118861, A15, MF-A03).
- MCEER-98-0005 "Screening Guide for Rapid Assessment of Liquefaction Hazard at Highway Bridge Sites," by T. L. Youd, 6/16/98, (PB99-118879, A06, not available on microfiche).
- MCEER-98-0006 "Structural Steel and Steel/Concrete Interface Details for Bridges," by P. Ritchie, N. Kaulh and J. Kulicki, 7/13/98, (PB99-118945, A06, MF-A01).
- MCEER-98-0007 "Capacity Design and Fatigue Analysis of Confined Concrete Columns," by A. Dutta and J.B. Mander, 7/14/98, (PB99-118960, A14, MF-A03).
- MCEER-98-0008 "Proceedings of the Workshop on Performance Criteria for Telecommunication Services Under Earthquake Conditions," edited by A.J. Schiff, 7/15/98, (PB99-118952, A08, MF-A02).
- MCEER-98-0009 "Fatigue Analysis of Unconfined Concrete Columns," by J.B. Mander, A. Dutta and J.H. Kim, 9/12/98, (PB99-123655, A10, MF-A02).
- MCEER-98-0010 "Centrifuge Modeling of Cyclic Lateral Response of Pile-Cap Systems and Seat-Type Abutments in Dry Sands," by A.D. Gadre and R. Dobry, 10/2/98, (PB99-123606, A13, MF-A03).
- MCEER-98-0011 "IDARC-BRIDGE: A Computational Platform for Seismic Damage Assessment of Bridge Structures," by A.M. Reinhorn, V. Simeonov, G. Mylonakis and Y. Reichman, 10/2/98, (PB99-162919, A15, MF-A03).
- MCEER-98-0012 "Experimental Investigation of the Dynamic Response of Two Bridges Before and After Retrofitting with Elastomeric Bearings," by D.A. Wendichansky, S.S. Chen and J.B. Mander, 10/2/98, (PB99-162927, A15, MF-A03).
- MCEER-98-0013 "Design Procedures for Hinge Restrainers and Hinge Sear Width for Multiple-Frame Bridges," by R. Des Roches and G.L. Fenves, 11/3/98, (PB99-140477, A13, MF-A03).
- MCEER-98-0014 "Response Modification Factors for Seismically Isolated Bridges," by M.C. Constantinou and J.K. Quarshie, 11/3/98, (PB99-140485, A14, MF-A03).
- MCEER-98-0015 "Proceedings of the U.S.-Italy Workshop on Seismic Protective Systems for Bridges," edited by I.M. Friedland and M.C. Constantinou, 11/3/98, (PB2000-101711, A22, MF-A04).
- MCEER-98-0016 "Appropriate Seismic Reliability for Critical Equipment Systems: Recommendations Based on Regional Analysis of Financial and Life Loss," by K. Porter, C. Scawthorn, C. Taylor and N. Blais, 11/10/98, (PB99-157265, A08, MF-A02).
- MCEER-98-0017 "Proceedings of the U.S. Japan Joint Seminar on Civil Infrastructure Systems Research," edited by M. Shinozuka and A. Rose, 11/12/98, (PB99-156713, A16, MF-A03).
- MCEER-98-0018 "Modeling of Pile Footings and Drilled Shafts for Seismic Design," by I. PoLam, M. Kapuskar and D. Chaudhuri, 12/21/98, (PB99-157257, A09, MF-A02).

- MCEER-99-0001 "Seismic Evaluation of a Masonry Infilled Reinforced Concrete Frame by Pseudodynamic Testing," by S.G. Buonopane and R.N. White, 2/16/99, (PB99-162851, A09, MF-A02).
- MCEER-99-0002 "Response History Analysis of Structures with Seismic Isolation and Energy Dissipation Systems: Verification Examples for Program SAP2000," by J. Scheller and M.C. Constantinou, 2/22/99, (PB99-162869, A08, MF-A02).
- MCEER-99-0003 "Experimental Study on the Seismic Design and Retrofit of Bridge Columns Including Axial Load Effects," by A. Dutta, T. Kokorina and J.B. Mander, 2/22/99, (PB99-162877, A09, MF-A02).
- MCEER-99-0004 "Experimental Study of Bridge Elastomeric and Other Isolation and Energy Dissipation Systems with Emphasis on Uplift Prevention and High Velocity Near-source Seismic Excitation," by A. Kasalanati and M. C. Constantinou, 2/26/99, (PB99-162885, A12, MF-A03).
- MCEER-99-0005 "Truss Modeling of Reinforced Concrete Shear-flexure Behavior," by J.H. Kim and J.B. Mander, 3/8/99, (PB99-163693, A12, MF-A03).
- MCEER-99-0006 "Experimental Investigation and Computational Modeling of Seismic Response of a 1:4 Scale Model Steel Structure with a Load Balancing Supplemental Damping System," by G. Pekcan, J.B. Mander and S.S. Chen, 4/2/99, (PB99-162893, A11, MF-A03).
- MCEER-99-0007 "Effect of Vertical Ground Motions on the Structural Response of Highway Bridges," by M.R. Button, C.J. Cronin and R.L. Mayes, 4/10/99, (PB2000-101411, A10, MF-A03).
- MCEER-99-0008 "Seismic Reliability Assessment of Critical Facilities: A Handbook, Supporting Documentation, and Model Code Provisions," by G.S. Johnson, R.E. Sheppard, M.D. Quilici, S.J. Eder and C.R. Scawthorn, 4/12/99, (PB2000-101701, A18, MF-A04).
- MCEER-99-0009 "Impact Assessment of Selected MCEER Highway Project Research on the Seismic Design of Highway Structures," by C. Rojahn, R. Mayes, D.G. Anderson, J.H. Clark, D'Appolonia Engineering, S. Gloyd and R.V. Nutt, 4/14/99, (PB99-162901, A10, MF-A02).
- MCEER-99-0010 "Site Factors and Site Categories in Seismic Codes," by R. Dobry, R. Ramos and M.S. Power, 7/19/99, (PB2000-101705, A08, MF-A02).
- MCEER-99-0011 "Restrainer Design Procedures for Multi-Span Simply-Supported Bridges," by M.J. Randall, M. Saiidi, E. Maragakis and T. Isakovic, 7/20/99, (PB2000-101702, A10, MF-A02).
- MCEER-99-0012 "Property Modification Factors for Seismic Isolation Bearings," by M.C. Constantinou, P. Tsopelas, A. Kasalanati and E. Wolff, 7/20/99, (PB2000-103387, A11, MF-A03).
- MCEER-99-0013 "Critical Seismic Issues for Existing Steel Bridges," by P. Ritchie, N. Kauh and J. Kulicki, 7/20/99, (PB2000-101697, A09, MF-A02).
- MCEER-99-0014 "Nonstructural Damage Database," by A. Kao, T.T. Soong and A. Vender, 7/24/99, (PB2000-101407, A06, MF-A01).
- MCEER-99-0015 "Guide to Remedial Measures for Liquefaction Mitigation at Existing Highway Bridge Sites," by H.G. Cooke and J. K. Mitchell, 7/26/99, (PB2000-101703, A11, MF-A03).
- MCEER-99-0016 "Proceedings of the MCEER Workshop on Ground Motion Methodologies for the Eastern United States," edited by N. Abrahamson and A. Becker, 8/11/99, (PB2000-103385, A07, MF-A02).
- MCEER-99-0017 "Quindío, Colombia Earthquake of January 25, 1999: Reconnaissance Report," by A.P. Asfura and P.J. Flores, 10/4/99, (PB2000-106893, A06, MF-A01).
- MCEER-99-0018 "Hysteretic Models for Cyclic Behavior of Deteriorating Inelastic Structures," by M.V. Sivaselvan and A.M. Reinhorn, 11/5/99, (PB2000-103386, A08, MF-A02).

- MCEER-99-0019 "Proceedings of the 7<sup>th</sup> U.S.- Japan Workshop on Earthquake Resistant Design of Lifeline Facilities and Countermeasures Against Soil Liquefaction," edited by T.D. O'Rourke, J.P. Bardet and M. Hamada, 11/19/99, (PB2000-103354, A99, MF-A06).
- MCEER-99-0020 "Development of Measurement Capability for Micro-Vibration Evaluations with Application to Chip Fabrication Facilities," by G.C. Lee, Z. Liang, J.W. Song, J.D. Shen and W.C. Liu, 12/1/99, (PB2000-105993, A08, MF-A02).
- MCEER-99-0021 "Design and Retrofit Methodology for Building Structures with Supplemental Energy Dissipating Systems," by G. Pekcan, J.B. Mander and S.S. Chen, 12/31/99, (PB2000-105994, A11, MF-A03).
- MCEER-00-0001 "The Marmara, Turkey Earthquake of August 17, 1999: Reconnaissance Report," edited by C. Scawthorn; with major contributions by M. Bruneau, R. Eguchi, T. Holzer, G. Johnson, J. Mander, J. Mitchell, W. Mitchell, A. Papageorgiou, C. Scaethorn, and G. Webb, 3/23/00, (PB2000-106200, A11, MF-A03).
- MCEER-00-0002 "Proceedings of the MCEER Workshop for Seismic Hazard Mitigation of Health Care Facilities," edited by G.C. Lee, M. Ettouney, M. Grigoriu, J. Hauer and J. Nigg, 3/29/00, (PB2000-106892, A08, MF-A02).
- MCEER-00-0003 "The Chi-Chi, Taiwan Earthquake of September 21, 1999: Reconnaissance Report," edited by G.C. Lee and C.H. Loh, with major contributions by G.C. Lee, M. Bruneau, I.G. Buckle, S.E. Chang, P.J. Flores, T.D. O'Rourke, M. Shinozuka, T.T. Soong, C-H. Loh, K-C. Chang, Z-J. Chen, J-S. Hwang, M-L. Lin, G-Y. Liu, K-C. Tsai, G.C. Yao and C-L. Yen, 4/30/00.
- MCEER-00-0004 "Seismic Retrofit of End-Sway Frames of Steel Deck-Truss Bridges with a Supplemental Tendon System: Experimental and Analytical Investigation," by G. Pekcan, J.B. Mander and S.S. Chen, 7/1/00.
- MCEER-00-0005 "Sliding Fragility of Unrestrained Equipment in Critical Facilities," by W.H. Chong and T.T. Soong, 7/5/00.
- MCEER-00-0006 "Seismic Response of Reinforced Concrete Bridge Pier Walls in the Weak Direction," by N. Abo-Shadi, M. Saiidi and D. Sanders, 7/17/00.
- MCEER-00-0007 "Low-Cycle Fatigue Behavior of Longitudinal Reinforcement in Reinforced Concrete Bridge Columns," by J. Brown and S.K. Kunnath, 7/23/00.
- MCEER-00-0008 "Soil Structure Interaction of Bridges for Seismic Analysis," I. PoLam and H. Law, 9/25/00.
- MCEER-00-0009 "Proceedings of the First MCEER Workshop on Mitigation of Earthquake Disaster by Advanced Technologies (MEDAT-1), edited by M. Shinozuka, D.J. Inman and T.D. O'Rourke, 11/10/00.
- MCEER-00-0010 "Development and Evaluation of Simplified Procedures for Analysis and Design of Buildings with Passive Energy Dissipation Systems," by O.M. Ramirez, M.C. Constantinou, C.A. Kircher, A.S. Whittaker, M.W. Johnson, J.D. Gomez and C. Chrysostomou, 11/16/01.
- MCEER-00-0011 "Dynamic Soil-Foundation-Structure Interaction Analyses of Large Caissons," by C-Y. Chang, C-M. Mok, Z-L. Wang, R. Settgast, F. Waggoner, M.A. Ketchum, H.M. Gonnermann and C-C. Chin, 12/30/00.
- MCEER-00-0012 "Experimental Evaluation of Seismic Performance of Bridge Restrainers," by A.G. Vlassis, E.M. Maragakis and M. Saiid Saiidi, 12/30/00.
- MCEER-00-0013 "Effect of Spatial Variation of Ground Motion on Highway Structures," by M. Shinozuka, V. Saxena and G. Deodatis, 12/31/00.
- MCEER-00-0014 "A Risk-Based Methodology for Assessing the Seismic Performance of Highway Systems," by S.D. Werner, C.E. Taylor, J.E. Moore, II, J.S. Walton and S. Cho, 12/31/00.
- MCEER-01-0001 "Experimental Investigation of P-Delta Effects to Collapse During Earthquakes," by D. Vian and M. Bruneau, 6/25/01.
- MCEER-01-0002 "Proceedings of the Second MCEER Workshop on Mitigation of Earthquake Disaster by Advanced Technologies (MEDAT-2)," edited by M. Bruneau and D.J. Inman, 7/23/01.



- MCEER-01-0003 “Sensitivity Analysis of Dynamic Systems Subjected to Seismic Loads,” by C. Roth and M. Grigoriu, 9/18/01.
- MCEER-01-0004 “Overcoming Obstacles to Implementing Earthquake Hazard Mitigation Policies: Stage 1 Report,” by D.J. Alesch and W.J. Petak, 12/17/01.
- MCEER-01-0005 “Updating Real-Time Earthquake Loss Estimates: Methods, Problems and Insights,” by C.E. Taylor, S.E. Chang and R.T. Eguchi, 12/17/01.
- MCEER-01-0006 “Experimental Investigation and Retrofit of Steel Pile Foundations and Pile Bents Under Cyclic Lateral Loadings,” by A. Shama, J. Mander, B. Blabac and S. Chen, 12/31/01.
- MCEER-02-0001 “Assessment of Performance of Bolu Viaduct in the 1999 Duzce Earthquake in Turkey” by P.C. Roussis, M.C. Constantinou, M. Erdik, E. Durukal and M. Dicleli, 5/8/02.
- MCEER-02-0002 “Seismic Behavior of Rail Counterweight Systems of Elevators in Buildings,” by M.P. Singh, Rildova and L.E. Suarez, 5/27/02.
- MCEER-02-0003 “Development of Analysis and Design Procedures for Spread Footings,” by G. Mylonakis, G. Gazetas, S. Nikolaou and A. Chauncey, 10/02/02.
- MCEER-02-0004 “Bare-Earth Algorithms for Use with SAR and LIDAR Digital Elevation Models,” by C.K. Huyck, R.T. Eguchi and B. Houshmand, 10/16/02.
- MCEER-02-0005 “Review of Energy Dissipation of Compression Members in Concentrically Braced Frames,” by K.Lee and M. Bruneau, 10/18/02.
- MCEER-03-0001 “Experimental Investigation of Light-Gauge Steel Plate Shear Walls for the Seismic Retrofit of Buildings” by J. Berman and M. Bruneau, 5/2/03.
- MCEER-03-0002 “Statistical Analysis of Fragility Curves,” by M. Shinozuka, M.Q. Feng, H. Kim, T. Uzawa and T. Ueda, 6/16/03.
- MCEER-03-0003 “Proceedings of the Eighth U.S.-Japan Workshop on Earthquake Resistant Design of Lifeline Facilities and Countermeasures Against Liquefaction,” edited by M. Hamada, J.P. Bardet and T.D. O’Rourke, 6/30/03.
- MCEER-03-0004 “Proceedings of the PRC-US Workshop on Seismic Analysis and Design of Special Bridges,” edited by L.C. Fan and G.C. Lee, 7/15/03.
- MCEER-03-0005 “Urban Disaster Recovery: A Framework and Simulation Model,” by S.B. Miles and S.E. Chang, 7/25/03.





MULTIDISCIPLINARY CENTER FOR EARTHQUAKE ENGINEERING RESEARCH

*A National Center of Excellence in Advanced Technology Applications*

University at Buffalo, State University of New York

Red Jacket Quadrangle ■ Buffalo, New York 14261

Phone: (716) 645-3391 ■ Fax: (716) 645-3399

E-mail: [mceer@mceermail.buffalo.edu](mailto:mceer@mceermail.buffalo.edu) ■ WWW Site <http://mceer.buffalo.edu>



University at Buffalo *The State University of New York*

ISSN 1520-295X