



[UB Motorsports Home](http://www.eng.buffalo.edu/sae)
www.eng.buffalo.edu/sae

UB MOTORSPORTS Formula SAE NEWSLETTER



University at Buffalo
The State University of New York

E-mail: UBFormulaSAE@gmail.com

March 2009

IN THIS ISSUE:

Now that manufacturing of our car is in full swing everyone on the team is very busy with various jobs. It is a crucial time for any team not to lose focus on the end goal and continue to work hard on every aspect of our vehicle. With the design complete it is a matter of self motivation that will bring us to competition. Please enjoy this newsletter and updates from all of our team leaders.

Suspension Team

The suspension design has gone out to manufacturing and we are awaiting parts to return from our sponsors Liston and AMC. We have begun to manufacture the connecting links for our front and rear suspensions in house.

One of the highlights of the design is our new uprights. These uprights carry over the toothed camber adjustment from last year, but are almost completely redesigned. They are designed to be set up with 6 deg of caster, for diagonal load transfer.

This caster is then adjustable by +3 and -3 degrees. This high degree of caster usually will lead to a very high steering effort, but our design incorporates a "caster offset," so that at the beginning 6 degree mark, we have only $\frac{1}{2}$ in of mechanical trail. According to our tyre data, this makes the driver effort around 10-15 pounds of force, in accordance with industrial engineering standards for sustainable work.

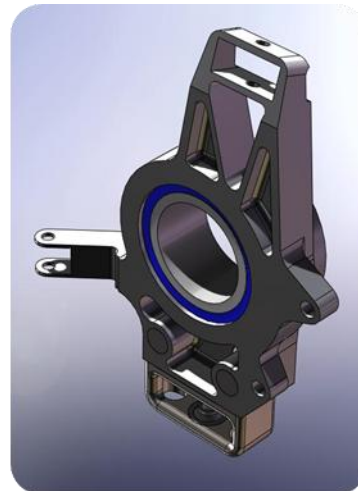

The camber is set at 0 degrees nominally, with adjustment to -3 degrees via a toothed adjustment system. The system is adjustable in $\frac{1}{4}$ degree increments this year, doubling the resolution from last year.

The uprights this year were designed with a small amount of pro-Ackermann steering, and removable steering attachments for testing of various degrees of Ackermann or Neutral steer.

The mass of the front uprights has been greatly reduced. The weight of the previous uprights was 3.63 pounds and we were able to reduce this to 2.40 pounds while maintaining less than 0.1 degrees of camber change under maximum cornering forces.



Chassis Team

Our chassis is 95% complete. Thanks to our machining sponsors we were able to receive a complete custom jig table and pre-machined frame tubes. This allowed us to assemble and weld almost the entire chassis in three days, a huge improvement over previous years.

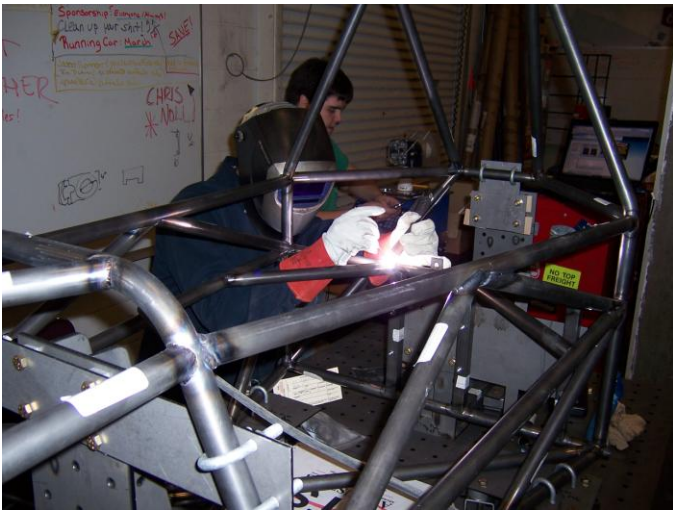

We would like to give a special thanks to Lee McElhenny for his generous welding services. We will next be starting our physical testing of the chassis to verify our design numbers for torsional stiffness, which involves restraining the rear end of the car while twisting the front to see how much it deforms.



Powertrain Team

Engine development for the UBMS09 is completed for this year. The new intake and exhaust designs are finalized, with production starting as soon as parts come in. Remaining work includes FEA of internal components to determine the safe redline and flow testing of the heads to confirm performance predictions.

Drivetrain design has been finalized for UBMS09. Bench testing of the clutches has determined the appropriate primary setup. Further drivetrain work is on hold until the car is running.



Electrical Team

Wow...March already? We're trying to get rolling in the manufacturing stages finally, but being that the electrical system pretty much has to wait until most things are finalized or in place, we are all getting impatient. A couple of the guys have been lending a hand around the shop to other subsystems to try and meet our deadlines, and things have been going alright thus far. We've ordered almost all of our parts, most of which are in the shop, and plan on getting the battery box finished, finalizing the dash/driver control panel, and possibly manufacturing that as soon as possible. Tim Plain and Chris Bookman lent a hand to the body/ergo team over the last week and a half to assist in getting the carbon fiber/kevlar attenuator laid up and vacuum bagged so we could do the destructive testing we needed. The experience was helpful in learning how to lay the carbon fabric and should benefit us as we manufacture an all carbon battery box. We will finalize one half of the main wiring harness and get that buttoned up while we wait as well.

Engineer's Week 2009

Well, E-week wrapped up well for us as we finished second overall, much to the dismay of the other clubs that were in the lead going into Friday. Congratulations to UB Robotics for knocking us off

our throne. We will return to the top of the heap next year. Most of the other clubs had trouble getting their bots together in time for their matches and we ended up getting byes in the first two rounds. We faced ASME in the semi-final, where we proceeded to completely disable their motor/weapon system within a minute by knocking the motor mount clear off it welds. In the finals we suffered a painful defeat at the hands of UB Robotics after they cut our weapons drive chain in half. We managed to knock their weapon out too, but apparently it wasn't as fatal to them according to the judges. After scrambling to get it back together after a brief recess we put in a decent showing, while UBR's batteries started to overheat and/or melt. The smell from them was absolutely rancid and inherently unhealthy. Overall the aluminum panels were really no match for their weapon and took an absolute beating. No actual structural damage was inflicted, but I guess that doesn't count for anything. A lot of the paint was forcibly removed, as expected, and lead to a nice war-torn look by the time we got out of the arena. We have a whole year to return to our previous glory, and fully plan on doing so next year. Thanks to everyone who stopped by and participated to represent our club and show our support for the Student Association, without your support we'd have finished in last place.





What being a new member of Formula SAE is like...

By Aaron Selkridge, first year member, Freshman Mechanical Engineering student.

My first real interest when I visited UB. I saw the car on display and being naturally passionate about the field, I knew it was something I wanted to be a part of. When I first joined, I wasn't so active, everyone there seemed to be so knowledgeable and I felt I lacked the knowledge in the field to prove my passion; so I was intimidated. I did not think I could tackle anything. But SAE wasn't having it, they made sure that if you were part of the club you were active, and so I was assigned something. Immediately I knew I wouldn't be able to handle what I was assigned. Should I say something? Should I remain quiet? I had no idea. But I knew I wouldn't be able to do anything unless I spoke, so I did. And I was surprised. Without a question they were helping me through the whole thing, informing me on what I didn't know while I put in work myself. It turns out a lot of the older team members started out not knowing anything either and some felt the same way I did, some weren't even engineering majors! I was shocked; but I was also comforted. It felt good to know I wasn't the only one, and as a team they were all there to support. It was different from most teams. In many teams you don't even get to have active participation until you have developed some clout. But as a part of SAE here I started working on the car right from the beginning and I have learned so much. Not only have I learned about cars, but about teamwork, business in the real world, as well as what it feels like to be a real engineer solving

real problems every day. In addition my character has grown where I have learned how to handle more responsibility and how to budget my time wisely. It's really exciting to be a part of, there is no way I would ever pass up an opportunity like this. I love it, and more than that I have become better because of it.

Thank you, Aaron for sharing your experience in our newsletter.

Thank you to all of our Sponsors and Advisors for another great month.

