

# MAE334 - Introduction to Instrumentation and Computers

## Final Exam

December 11, 2006

- Closed Book and Notes
- No Calculators

1. Fill in your name on side 2 of the scoring sheet (Last name first!)
2. Fill in your 8-digit person number on your scoring sheet.
3. Fill in circle 1 under GRADE OR EDUCATION on your scoring sheet. This is your test number! You will receive a ZERO if you do not indicate your test number.

SEX	FEMALE	<input type="radio"/>	MALE	<input type="radio"/>	IDENTIFICATION NUMBER										
BIRTH DATE	Yr.   Mo.		SPECIAL CODES												
	0	0	0	0							0	0	0	0	0
	1	1	1	1							1	1	1	1	1
	2	2	2	2							2	2	2	2	2
	3	3	3	3							3	3	3	3	3
	4	4	4	4							4	4	4	4	4
	5	5	5	5							5	5	5	5	5
	6	6	6	6							6	6	6	6	6
	7	7	7	7							7	7	7	7	7
	8	8	8	8							8	8	8	8	8
	9	9	9	9							9	9	9	9	9
DO NOT WRITE IN THIS SPACE					GRADE OR EDUCATION										
					1	5	9	13							
					2	6	10	14							
					3	7	11	15							
					4	8	12	16							

- For each question, choose THE BEST ANSWER and mark the corresponding answer on the scoring sheet.
- There is only 1 best answer per question.

The last page of the exam has the “Student-t Distribution Table” and the

“Probability Values for Normal Error Function  $z_1 = \frac{x_1 - x'}{\sigma}$ ”

1. The static sensitivity of a thermistor is normally considered to be a constant over the temperature range it was design to be used in.
  - a. True
  - b. False
2. In lab 2 the thermocouple response was linearized by taking the natural log of the function,  $\ln \left[ \frac{(T_0 - T(t))}{(T_0 - T_\infty)} \right]$ , where  $t$  is time and  $T$ , is temperature.
  - a. True
  - b. False
3. Repeated measurements of a static temperature reading will
  - a. Have a normal distribution
  - b. Show the bias error
  - c. Can be used to determine the measurement system precision
  - d. All of the above
  - e. None of the above
4. An 8 bit ADC with an  $\pm 12.8$  volt input signal range subjected to a 2.26 volt signal will output a value.
  - a. 2
  - b. 22
  - c. 23
  - d. 46
  - e. None of the above

A temperature sensor is to be selected to measure the fluctuating temperature within a cylinder of an internal combustion engine. It is suspected that the temperature will behave as a periodic waveform with a frequency around 180 radians/second. (Rotating at 1800 rpm). Several size sensors are available, each with a known time constant.

5. What percent reduction in output/input signal magnitude would you expect at the 1800 cycle/minute frequency from a thermocouple with a 1/9 of a second time constant? (assume  $\pi = 3$  and static sensitivity,  $K=1$ )
  - a. 5%
  - b. 30%
  - c. 70%
  - d. 95%
  - e. None of the above
6. If you were required to maintain a dynamic error of less than 29.3% ( $M(\omega) \geq 70.7\% = 1/\sqrt{2}$ ) for the internal combustion engine temperature measurement described above what would be an acceptable thermocouple time constant?
  - a. 1/180 seconds
  - b. 1/90 seconds
  - c. 1/60 seconds
  - d. 1/30 seconds
  - e. None of the above

7. Thermistors are normally not as sensitive as RTDs, but are much less expensive to manufacture.
  - a. True
  - b. False
8. An inclined manometer with an indicating leg at  $30^\circ$  containing colored water (specific weight,  $\gamma = 1.0$ ) is used to measure pressure. What is the static sensitivity of the manometer in (Inches of Water/Inches of deflection)?
  - a. 0.5
  - b. 1.0
  - c. 1.5
  - d. 2.0
  - e. None of the above
9. A strain-gauge equipped diaphragm pressure transducer is a null device with a dynamic behavior described as a second-order system.
  - a. True
  - b. False
10. An under damped second order system will *always* oscillate with a greater amplitude than the forcing when the input forcing is at the natural frequency.
  - a. True
  - b. False
11. The precision error associated with the ADC used in our lab can not be less than
  - a.  $10/200/2^{12}$  Volts
  - b.  $20/200/2^{12}$  Volts
  - c.  $20/2^{12}$  Volts
  - d. None of the above
12. It is known that the statistics of a normally distributed temperature signal are  $x' = 20^\circ\text{C}$  and  $\sigma^2 = 4^\circ\text{C}^2$ . What is the probability that a measurement will yield a value outside the range of 16 to  $24^\circ\text{C}$ ?
  - a. 5%
  - b. 32%
  - c. 34%
  - d. 48%
  - e. 52%
13. The input impedance of a deflection device such as a Bourdon Tube pressure gauge is inversely proportional to static sensitivity.
  - a. True
  - b. False
14. An extraneous variable in an experiment usually refers to *all possible* unaccounted for or uncontrollable variables that can affect the value of the measured variable.
  - a. True
  - b. False

Table 1. Sample data set with a normal distribution, a mean value of 1.0 and a standard deviation of 0.15 and a plot of the data set with a linear curve fit added.

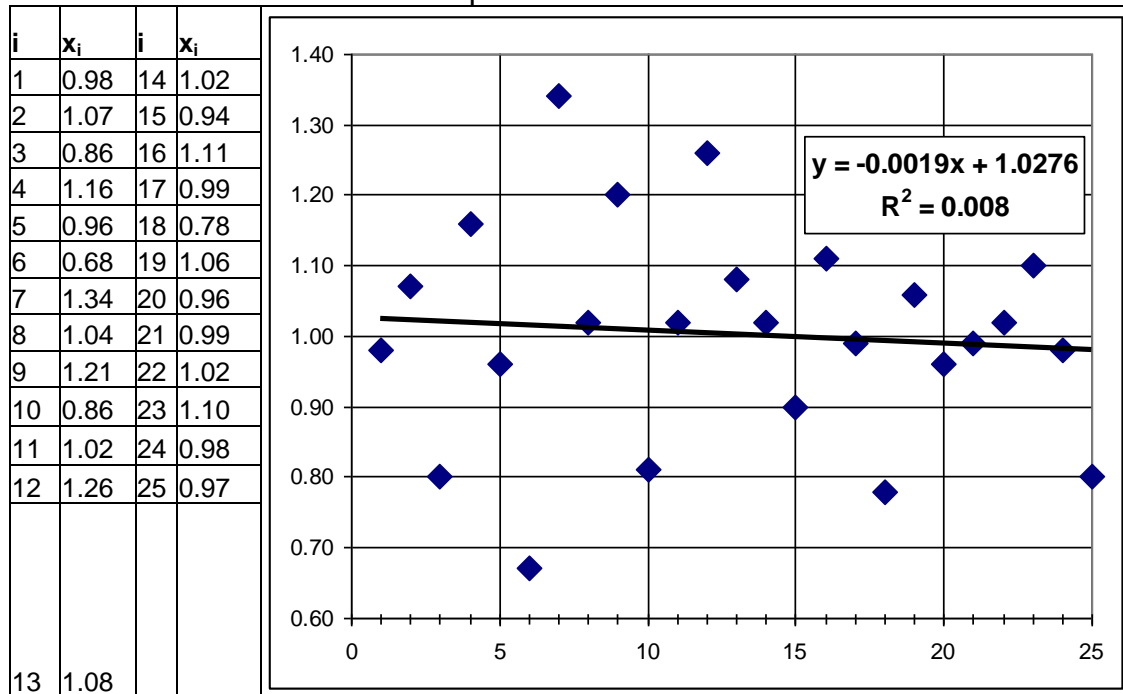

15. Given the data set in Table 1, what is the probability of recording a value within the range of  $1.0 \pm 0.30$
- 50%
  - 90%
  - 95%
  - 99%
  - None of the above
16. Given the data set in Table 1, give an estimate of the true mean value of the measurand at 99% probability
- $x' = \bar{x} \pm (2.787 \times 0.03)$
  - $x' = \bar{x} \pm (2.797 \times 0.03)$
  - $x' = \bar{x} \pm (2.787 \times 0.15)$
  - $x' = \bar{x} \pm (2.797 \times 0.15)$
  - None of the above
17. The line fit to the data set in Table 1 has how many degrees of freedom?
- 1
  - 2
  - 3
  - 4
18. The correlation coefficient,  $R^2$  value of 0.008, indicates a high quality fit to the data in Table 1.
- True
  - False

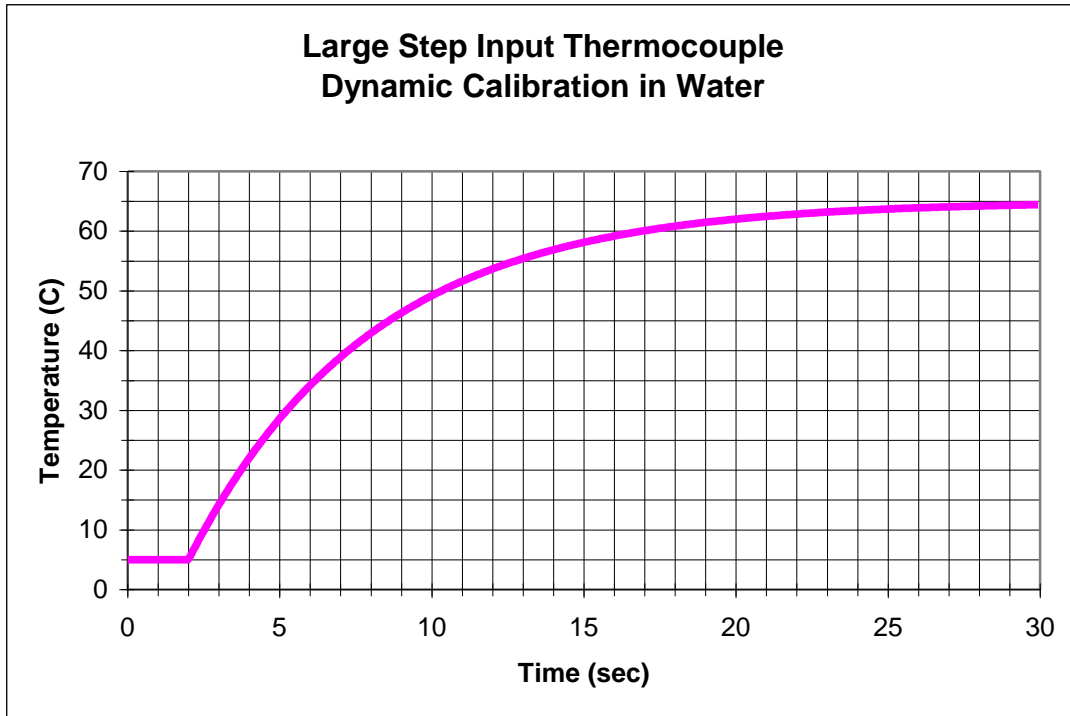

Figure 1. Data set from Lab 2 dynamic calibration.

19. The approximate time constant,  $\tau$ , of the thermocouple response plotted in Figure 1 is:
- a. 5 seconds
  - b. 6 seconds
  - c. 10 seconds
  - d. 15 seconds
  - e. 24 seconds
20. If a thermocouple is more sensitive (the static sensitivity is larger) the dynamic response would be faster (the time constant would be smaller).
- a. True
  - b. False
21. The ADC used in the lab would output what binary value corresponding to -4?
- a. 111111111100
  - b. 100000000100
  - c. 000000000100
  - d. 111111111011
  - e. None of the above
- |  |  |  |  |  |  |  |  |  |  |
|--|--|--|--|--|--|--|--|--|--|
|  |  |  |  |  |  |  |  |  |  |
|  |  |  |  |  |  |  |  |  |  |
|  |  |  |  |  |  |  |  |  |  |
|  |  |  |  |  |  |  |  |  |  |
22. The ADC used in our lab has what type of architecture?
- a. Flash
  - b. Pipelined
  - c. Successive approximation
  - d. Sigma-delta

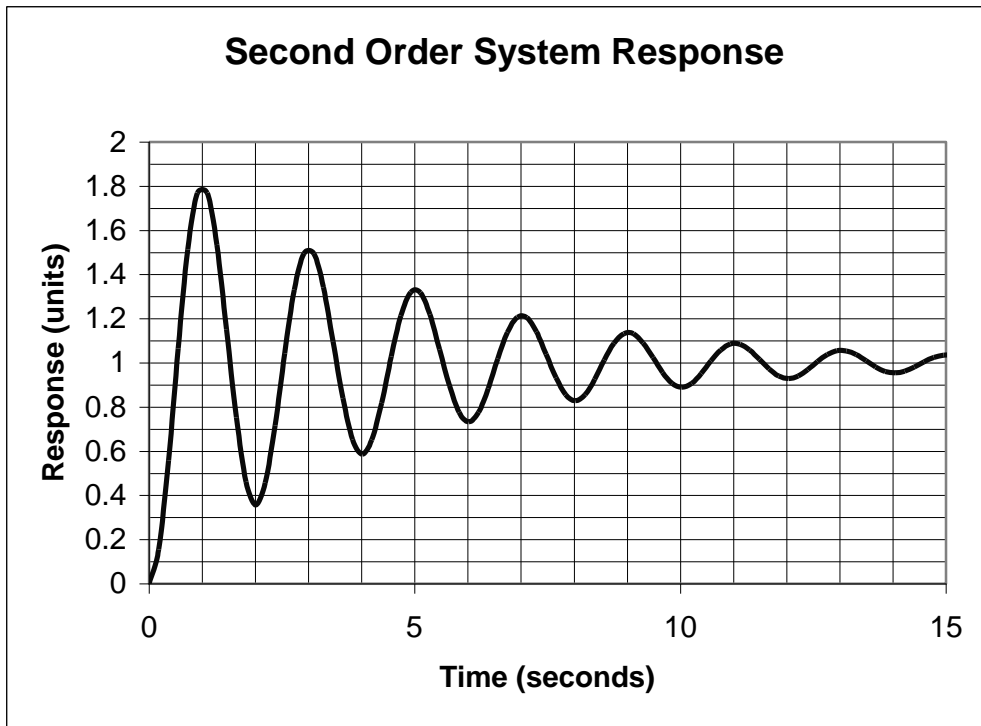

Figure 2. Pressure transducer time response to a step input function.

23. The rise time in seconds of the pressure transducer plotted in Figure 2 is approximately
- 0.5
  - 1.0
  - 10.
  - None of the above
24. The natural frequency of the pressure transducer plotted in Figure 2 is very close to
- 0.5 Hz
  - 1.0 Hz
  - 10 Hz
  - None of the above
25. The ADC architecture normally associated with the best resolution is
- Flash
  - Pipelined
  - Successive approximation
  - Sigma-delta
26. A 55 Hz sine wave sampled at 100 Hz will result in a sampled data set with what frequency
- 45 Hz
  - 55 Hz
  - 5 Hz
  - none of the above

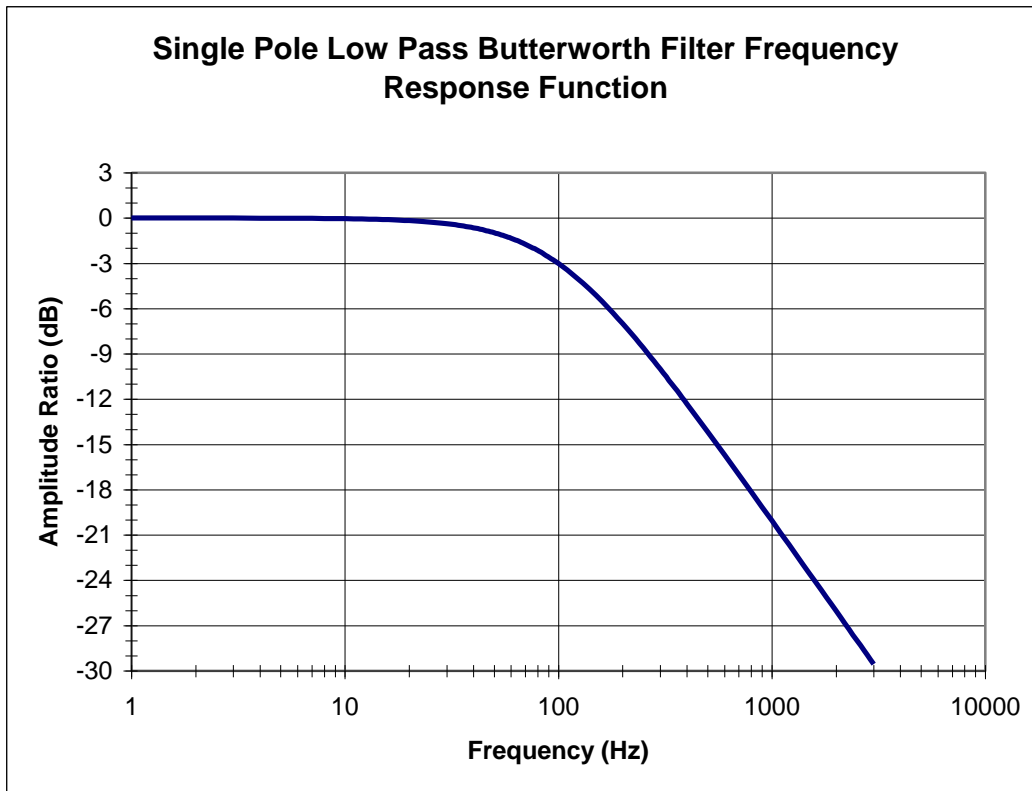

Figure 3. Filter amplitude ratio,  $M(f)$ , of a low pass filter.

27. What is the cut-off frequency of the filter whose response function is plotted in Figure 3?
- 9 Hz
  - 50 Hz
  - 100 Hz
  - 200 Hz
  - None of the above
28. Given a  $5000 \Omega$  resistor and  $1 \mu\text{F}$  capacitor what is the Butterworth lowpass filter corner frequency in Hertz?
- $2\pi * 5000 * 10^{-6}$
  - $1/(2\pi * 5000 * 10^{-6})$
  - $5000 * 10^{-6}$
  - $1/(5000 * 10^{-6})$
  - None of the above
29. What is the input impedance of an ideal op amp?
- Zero
  - Infinity
  - None of the above
30. What is the output impedance of an ideal op amp?
- Zero
  - Infinity
  - None of the above

### Design Stage Uncertainty Problem

An ADC is to be used to measure the output from a thermocouple. The nominal temperature expected will be about 20 °C. Estimate the design-stage uncertainty in this combination. The following information is available:

ADC		
Gain:	1	
Range:		±1 volt
Resolution:	10 bits	
Accuracy:		within 0.001% of reading
Thermocouple		
Sensitivity:	10 <sup>-4</sup> V/°C	
Linearity:		within 1 mV/°C over range
Repeatability:		within 2 mV/°C over range
Resolution:		negligible

31. The voltage measurement design stage uncertainty of the ADC is

- $u_0 = \pm \frac{1}{2} \left( \frac{2}{2^{10}} \right)$
- $(u_d)_E = \pm \sqrt{\left( \frac{1}{2} \left( \frac{2}{2^{10}} \right) \right)_E^2 + (2 \times 10^{-8})_E^2}$
- $(u_d)_E = \pm \frac{1}{2} \sqrt{\left( \frac{2}{2^{10}} \right)_E^2 + (2 \times 10^{-8})_E^2}$
- None of the above

32. The design stage uncertainty of the thermocouple can be assumed to be

- $\pm \sqrt{[1\text{mV}/^\circ\text{C} \times 20^\circ\text{C}]^2 + [2\text{mV}/^\circ\text{C} \times 20^\circ\text{C}]^2}$
- $\pm \frac{1}{2} \sqrt{[1\text{mV}/^\circ\text{C} \times 20^\circ\text{C}]^2 + [2\text{mV}/^\circ\text{C} \times 20^\circ\text{C}]^2}$
- $\pm \sqrt{[1\text{mV}]^2 + [2\text{mV}]^2}$
- None of the above

33. The delta function integral  $\int_{-\infty}^{+\infty} \delta(t) dt$  is defined to be equal to:

- 1
- $\frac{1}{2}$
- 0
- 1
- None of the above

34. Velocity and Voltage are both effort variables.

- True
- False



35. A linear potentiometer as used in the fourth lab in combination with the ADC used to acquire the output voltage has a position measurement zero order uncertainty of \_\_\_\_\_ where K is the static sensitivity of the position vs. voltage calibration and Q is the resolution of the ADC.
- $\pm \frac{1}{2} (K Q)$
  - $\pm (K Q)$
  - $\pm \frac{1}{2} Q$
  - $\pm Q$
  - None of the above
36. The only filter covered in class that has a linear phase shift (does not scramble the phase and could be used for audio signal filtering) is a
- Bessel
  - Butterworth
  - Chebyshev
  - Elliptic
37. For the Fourier series given by  $y(t) = 4 + \sum_{n=1}^{\infty} \frac{2n\pi}{10} \cos \frac{n\pi}{4} t + \frac{120n\pi}{30} \sin \frac{n\pi}{4} t$  where  $t$  is time in seconds. What is the fundamental frequency in hertz?
- $\pi/4$
  - 1/10
  - 1/8
  - 1/4
  - None of the above

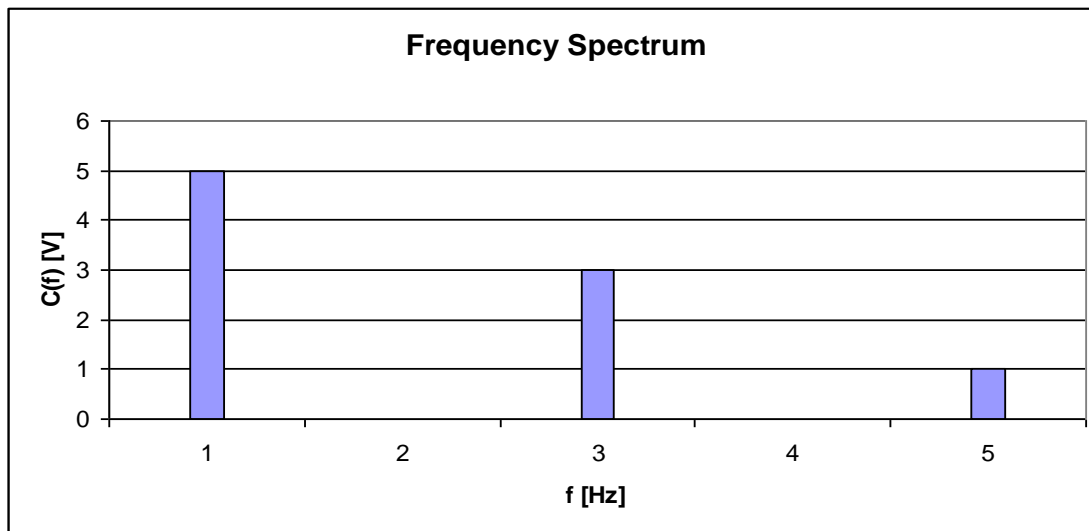

Figure 4. Spectrum for problem 38

38. Which of the following describes the frequency spectrum plotted in Figure 4.
- $5 \sin(2\pi t) + 3 \sin(6\pi t) + \sin(10\pi t)$
  - $5 \sin(\pi t) + 3 \sin(3\pi t) + \sin(5\pi t)$
  - $5 \sin(t) + 3 \sin(3t) + \sin(5t)$
  - $5 \sin\left(\frac{t}{2\pi}\right) + 3 \sin\left(\frac{3t}{2\pi}\right) + \sin\left(\frac{5t}{2\pi}\right)$

39. The frequency spectrum of a data set sampled at 100 samples/second for 2 seconds will have a frequency spacing or resolution in frequency space of
- 1/2 Hz
  - 1 Hz
  - 2 Hz
  - 50 Hz
  - 100 Hz
40. The frequency spectrum of a data set sampled at 200 samples/second for 10 seconds will have a maximum frequency of
- 1/10 Hz
  - 10 Hz
  - 100 Hz
  - 200 Hz
  - 2000 Hz
41. A tachometer has an analog display dial graduated in 5 revolutions per minute (rpm) increments. Estimate the zero order uncertainty in this instrument
- $\pm 5$  rpm
  - 5 rpm
  - $\pm 2.5$  rpm
  - 2.5 rpm
42. The users manual states an accuracy of 1% of the reading for a tachometer with an analog display dial graduated in 5 revolutions per minute (rpm) increments. Estimate the design stage uncertainty at 5000 rpm.
- $\pm 52.5$  rpm
  - $\pm 55$  rpm
  - $\pm 50$  rpm
  - $\pm (2525)^{1/2}$
43. The cooling of a thermometer can be modeled as a first-order system with  $\Gamma = e^{-t/\tau}$ . If  $\Gamma$  can be measured within 2% and time within 1%, what is the uncertainty,  $u_\tau$ , in the ability to determine the time constant,  $\tau$ . Remember  $\tau = -t / \ln \Gamma$ .
- $u_\tau = \pm \left[ \left( \frac{\partial \tau}{\partial t} u_t \right)^2 + \left( \frac{\partial \tau}{\partial \Gamma} u_\Gamma \right)^2 \right]^{1/2}$
  - $u_\tau = \pm \left[ \left( \frac{u_t}{\ln \Gamma} \right)^2 + \left( \frac{u_\Gamma}{\Gamma (\ln \Gamma)^2} \right)^2 \right]^{1/2}$
  - All of the above
  - None of the above

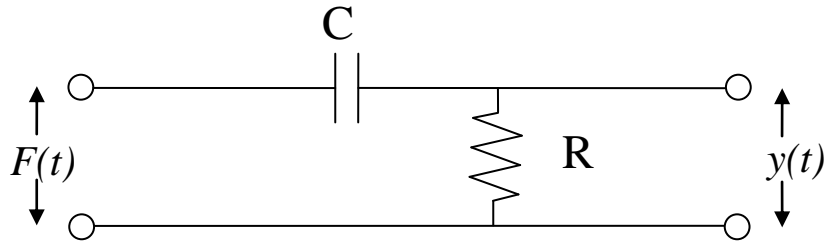

Figure 5. Filter Circuit

44. The filter depicted in Figure 5 is a
- Low-pass Bessel filter
  - Low-pass Butterworth filter
  - High-pass Bessel filter
  - High-pass Butterworth filter

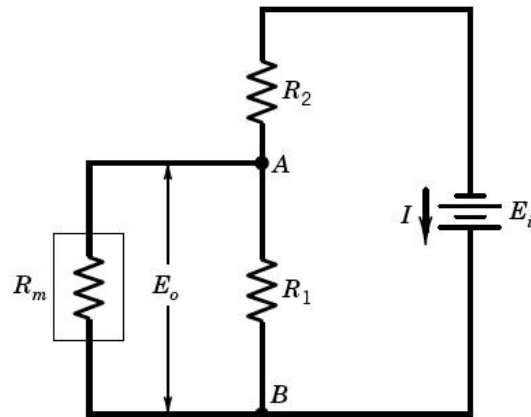

Figure 6. Instruments in parallel to signal path form an equivalent voltage dividing circuit.

45. Referring to Figure 6. If,  $R_m$ , is the resistance of the meter used to measure a thermistor whose resistance is  $R_1$  what is the equivalent resistance,  $R_L$ , of the parallel loop formed by  $R_m$  and  $R_1$ ?

- $R_L = \frac{R_1 R_m}{R_1 + R_m}$
- $R_L = \frac{R_1 + R_m}{R_1 R_m}$
- $R_L = R_1 + R_m$

46. Referring to Figure 6. The loading error goes to zero as  $R_m$  goes to zero.

- True
- False

47. Referring to Figure 6. The impedance of the meter used to measure the resistance  $R_1$  is

- $R_m$
- $1/R_m$

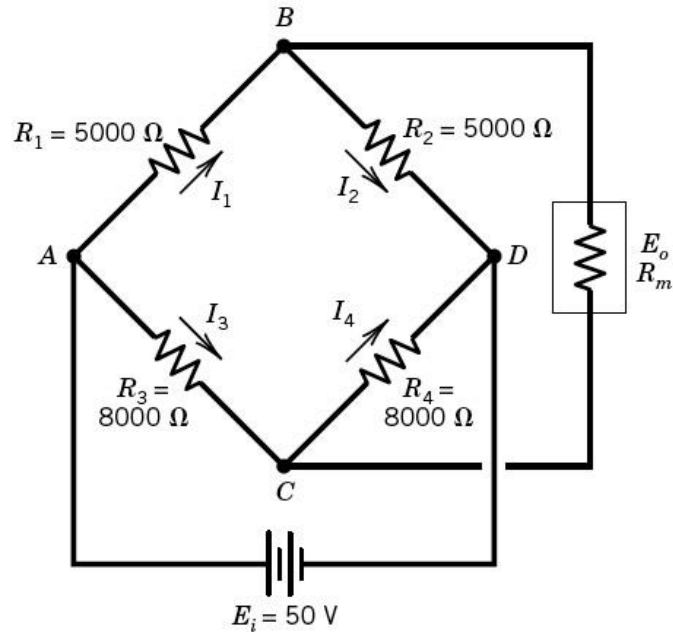

Figure 7. Wheatstone bridge circuit for question 48.

48. If the meter has infinite impedance the bridge in Figure 7 has an output voltage,  $E_o$ , of

- $E_o = E_i \left( \frac{R_1}{R_1 + R_2} + \frac{R_3}{R_3 + R_4} \right)$
- $E_o = E_i \left( \frac{R_1 R_3}{R_1 + R_2 + R_3 + R_4} \right)$
- $E_o = E_i \left( \frac{(R_1 + R_2)(R_3 + R_4)}{R_1 + R_2 + R_3 + R_4} \right)$
- $E_o = E_i \left( \frac{(R_1 + R_3)(R_2 + R_4)}{R_1 + R_2 + R_3 + R_4} \right)$

49. At resistances given for the bridge in Figure 7 this bridge can be said to be balanced.

- True
- False

50. The error function of a thermocouple subjected to a step input will vary from

- 1 to 0
- 0 to  $-\infty$
- $T_0$  to  $T_\infty$
- 1 to 0
- None of the above

51. Flow variables should be measured with a sensor with very high input impedance.

- True
- False

52. The output impedance of a thermistor circuit should be much greater than the input impedance of the volt meter used to record the output.
- True
  - False
53. If we want to maximize the power output of an audio speaker system the output impedance of the amplifier driving the speakers should be the same as the input impedance of the speakers.
- True
  - False
54. The impedance of a thermometer is inversely proportional to its heat capacity.
- True
  - False

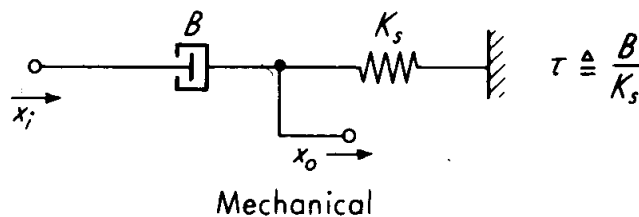

Figure 8. A mechanical filter schematic

55. The mechanical filter schematic in Figure 8 is of a low-pass filter
- True
  - False
56. A sensor which can be modeled as a first-order system will induce a linear phase shift of the input signal.
- True
  - False
57. A linear potentiometer can be modeled as a first-order system.
- True
  - False
58. An interferometer has a precision which is proportional to the wavelength of the laser light used by the instrument.
- True
  - False
59. A linear variable differential transformer is based on a variable resistor or potentiometer to sense position.
- True
  - False

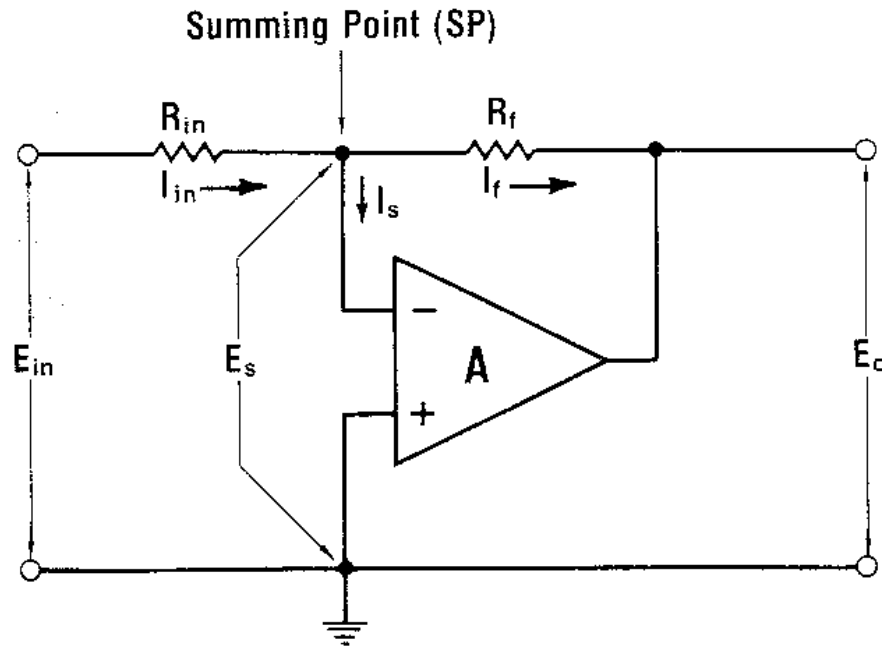

Figure 9. Basic operational amplifier circuit.

60. The op amp circuit in Figure 9 is a
- Summing amp
  - Integrating amp
  - Inverting amp
  - Non-inverting amp
61. The voltage  $E_s$  in Figure 9 is
- $E_s = I_{in} R_{in}$
  - $E_s = E_o$
  - $E_s = 0$
  - None of the above
62. The gain of the op amp circuit in Figure 9 is
- $R_f/R_{in}$
  - $-R_f/R_{in}$
  - $R_{in}/R_f$
  - $-R_{in}/R_f$
  - None of the above
63. The current  $I_s$  in Figure 9 is
- $I_s = I_{in}$
  - $I_s = I_f$
  - $I_s = 0$
  - $-E_o/R_f$
  - None of the above
64. If the op amp in Figure 9 is assumed to be ideal the input impedance circuit would be infinite.
- True
  - False

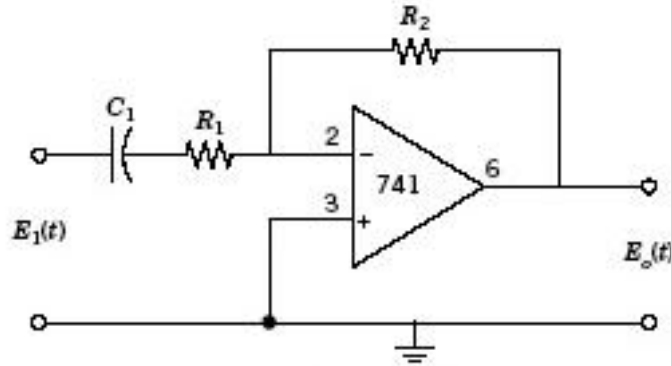

Figure 10. Active filter circuit.

65. The active filter in Figure 10 is a low-pass filter.
- True
  - False
66. As the number of stages of a filter increases the filter cut off point,  $f_c$ , decreases.
- True
  - False
67. In lab 3 (Transient Thermal Behavior with Work and Heat Loss) the rate of increase in temperature,  $dT/dt$ , of the calorimeter is linearly proportional to rate at which you turned the calorimeter handle.
- True in all cases
  - True when the calorimeter is significantly hotter than the lab air temperature
  - Approximately true when the calorimeter is at the lab air temperature
  - Never true
68. In lab 3 the cooling studies were used to
- Determine the overall convection factor,  $H$ .
  - Determine the time constant,  $\tau$ , of the calorimeter
  - All of the above
  - None of the above
69. In lab 4s, Strain Gage Experiences, the first two unloaded beam natural frequencies could be found. The second or higher natural frequency of the beam was of similar magnitude to the fundamental frequency.
- True
  - False
70. In lab 4s, Strain Gage Experiences, the experimental deflection data was predicted with reasonable accuracy by the experimental deflection calculation.
- True
  - False

71. In lab 4C, Studying the Behavior of a Compressed Gas, the transient behavior of the sudden gas expansion accurately resembled (and could be well modeled as) a second order system.
- True
  - False
72. In lab 5A, Study of Accelerometer Instrumentation, the accelerometers used in this lab were set to compensate for gravity. In other words they are not sensitive to orientation.
- True
  - False
73. In lab 5A, Study of Accelerometer Instrumentation, the rigidizing process of the stainless steel strip was intended to decrease the natural frequency of the beam?
- True
  - False
74. In lab 5A, Study of Accelerometer Instrumentation, when a mass was added to the beam the natural frequency increased.
- True
  - False
75. In lab 5F, Filtering and Dynamic Behavior with a First Order Filter, the transient response of the filter was found by inputting a square wave into the filter.
- True
  - False
76. The filter tested in lab 5F, Filtering and Dynamic Behavior with a First Order Filter, was found to be a 1<sup>st</sup> order Butterworth filter with a time constant,  $\tau$ , equal to RC, where R is the resistor resistance in ohms and C is the capacitance in Farads.
- True
  - False
77. Accuracy is a measure of the ability to represent a true (known) value.
- True
  - False
78. Given a data set with 50 values, a sample mean of 2.0 and a sample standard deviation of 0.2. Approximately 99% of the data points will lie in the range of
- $2.0 \pm (0.2)(2.678)$
  - $2.0 \pm (0.2)(2.680)$
  - $2.0 \pm (0.2)(2.682)$
  - none of the above
79. The slope of the linearized error function,  $\Gamma(t)$ , of a 1<sup>st</sup> order system is
- $\tau$
  - $1/\tau$
  - $-1/\tau$
  - $-t/\tau$



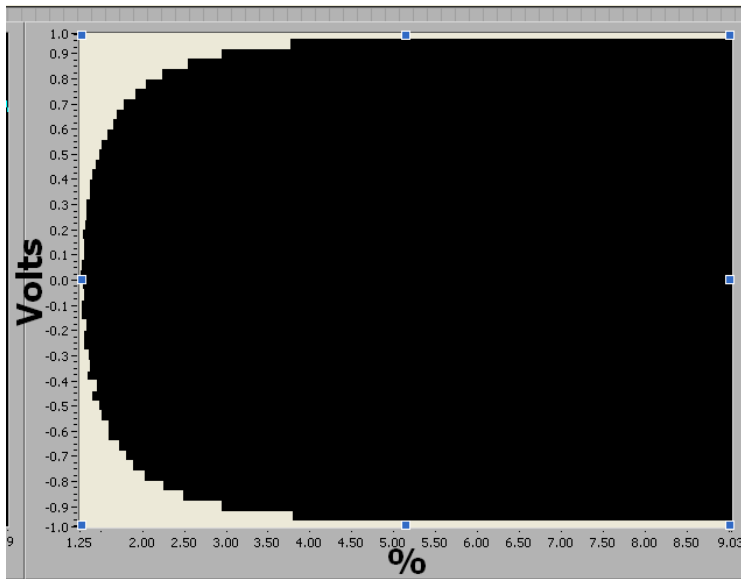
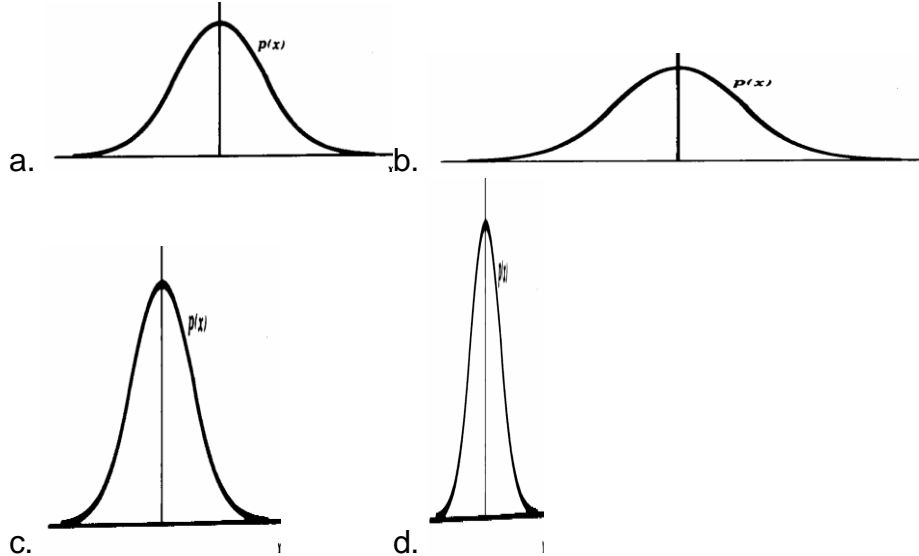

Figure 11. Signal histogram

80. The signal whose histogram is plotted in Figure 11 spends approximately how much of its time below -0.9 volts.
- 3.75 %
  - 9.03 %
  - 12.78%
  - None of the above

81. Given the following probability density functions. Which signal has the largest standard deviation?



82. The slope of the static calibration curve is known as the:
- Response function
  - Time constant
  - Static sensitivity
  - None of the above

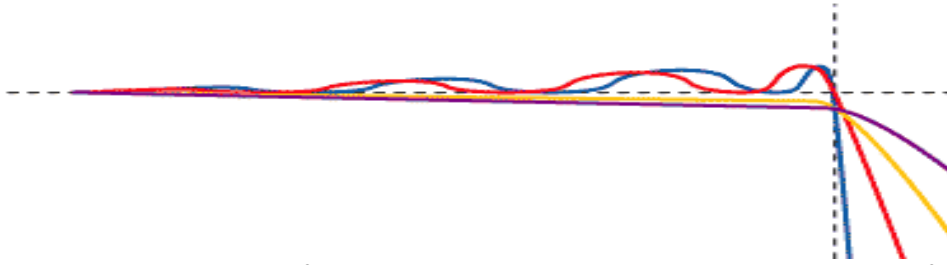

Figure 12. Low pass filter magnitude response in dB versus log of frequency of four different filter types, Butterworth, Bessel, Elliptic and Chebyshev, all with the same cut off frequency.

83. Of all the filter response characteristics plotted in Figure 12, the Elliptic filter is most likely to have the steepest magnitude roll off as the frequency increases.
- True
  - False
84. Of all the filter response characteristics plotted in Figure 12, the Bessel filter is most likely to have the most gradual magnitude roll off as the frequency increases.
- True
  - False
85. Heat flux is a flow variable.
- true
  - false
86. The time constant,  $\tau$ , of a thermocouple
- Is smaller when subjected to a larger step input
  - Is larger when subjected to a larger step input
  - Is not effected by the input signal
  - Is constant as long as the mass of the thermocouple does not change
87. If you would like to resolve the daily, weekly, monthly and annual temperature fluctuations at your home what is the least amount of data you must collect?
- once a day for one week
  - once a day for 6 months
  - twice a day for 6 months
  - twice a day for 12 months
88. To estimate the 95% confidence interval for a linear curve fit of 15 data points you would use the formula
- $C.I. = \pm t_{13,95} S_{\bar{x}}$
  - $C.I. = \pm t_{15,95} S_{xy}$
  - $C.I. = \pm t_{13,95} S_x$
  - $C.I. = \pm t_{13,95} S_{xy}$
  - None of the above

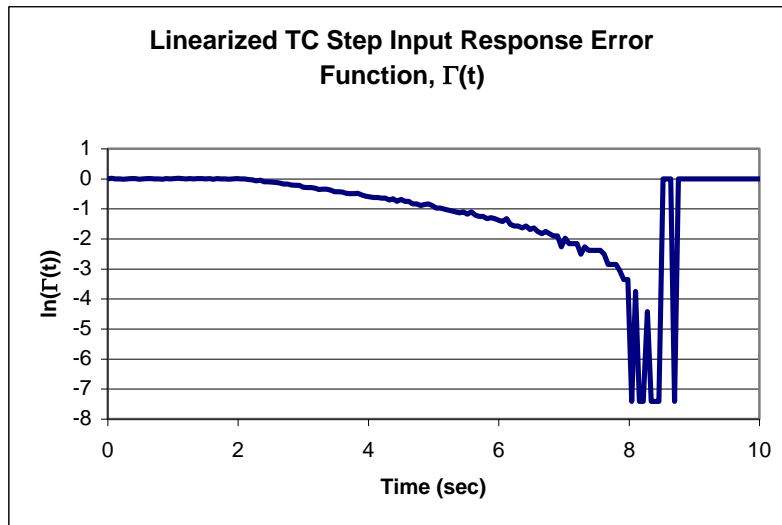

Figure 13. Linearized step input response error function.

89. While linearizing the dynamic calibration data taken during lab #2 report using equation:  $\ln\left\{\frac{(T(t)-T_0)}{(T_f-T_0)}\right\}=-t/\tau$  you obtain a curve like the one in Figure 13. This plot is indicative of
- a well collected, properly processed data set with quantization error at the end of the record.
  - a truncated data set or a poor estimation of  $T_f$ .
  - a data set with too much noise to properly analyze.
  - none of the above

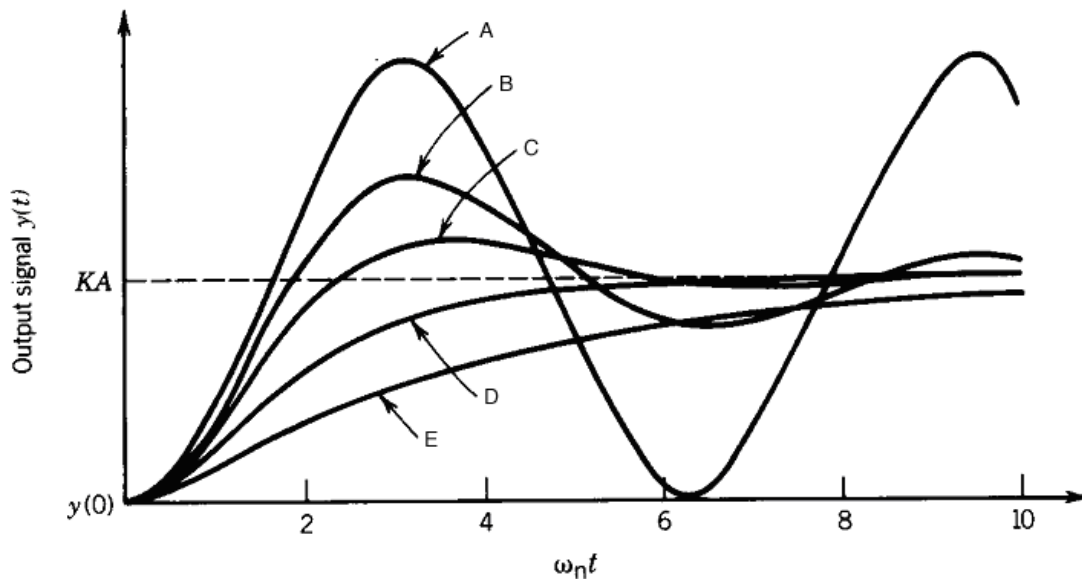
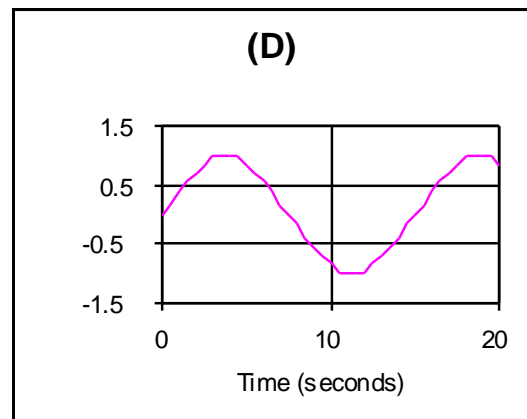
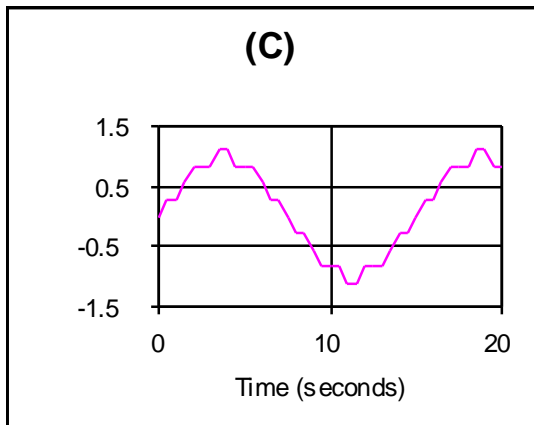
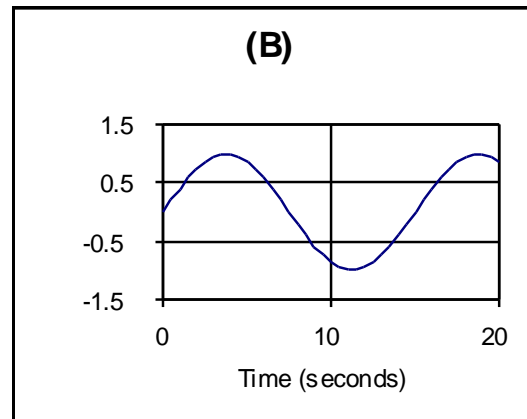
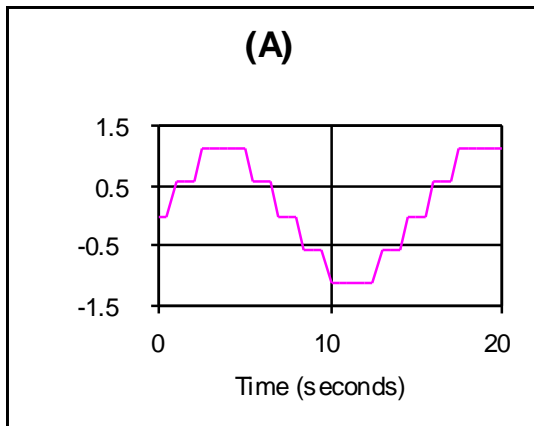

Figure 14. A plot of the response of a second order system of various damping ratios to a step input function.

90. In the figure above (Figure 14) which curve has a damping ratio,  $\xi$ , of 1
91. In the figure above (Figure 14) which curve has a damping ratio,  $\xi$ , of 0.25



92. If the input signal is a true sine wave which of the above graphs shows the least quantization error.
93. The sine wave in the above graphs has a frequency of
- 15 Hertz
  - .15 Hertz
  - $2\pi/15$  Radians/Second
  - $30\pi$  Radians/Second
  - $15\pi$  Radians/Second
94. Which of the following temperature sensors is the least expensive to purchase and implement?
- Thermocouple
  - Thermistor
  - Infra Red Detector
  - RTD
95. When an instrument manufacturer lists an accuracy (of for example 1 minute/month for my stopwatch) what is the assumed uncertainty percentage?
- 90 %
  - 95%
  - 99%
  - None of the above

96. If the speedometer in a car has 5 mph increments and an accuracy of 5% what is the uncertainty at 50 mph

- a.  $\sqrt{5^2 + 2.5^2}$
- b.  $\sqrt{2.5^2 + 2.5^2}$
- c.  $\sqrt{5 + 2.5}$
- d.  $\sqrt{5}$

97. The following equation is used to simulate a digitized sinusoidal signal.

$$Y = \sin(2\pi fn/f_s)$$

Where  $f$  is signal frequency;  $f_s$  is sampling frequency;  $n=1,2,3,\dots,500$ . If  $f = 100$  Hz and  $f_s = 200$  Hz what will the output signal look like?

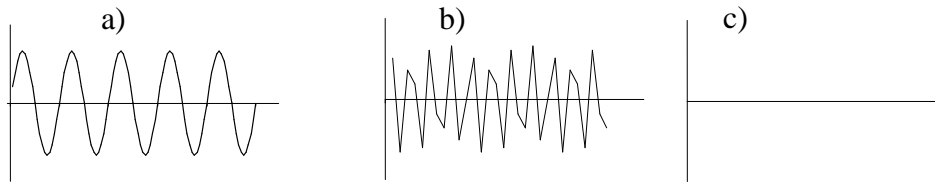

98. The time constant ( $\tau$ ) of a thermocouple can be effected by the following factor(s)?

- a. size of the temperature step
  - b. the direction of the temperature change
  - c. the medium around the thermocouple
  - d. all of the above
99. After performing a linear regression on the temperature vs. time data collected while turning the calorimeter drum lab #3, you found that the quality of the fit improved as the lab progressed (the temperature of the calorimeter drum increased).
- a. True
  - b. False
100. Amplitude ambiguity will occur in a Fourier transformation of a periodic signal if the period chosen for transformation does not contain an integral multiple of the frequency of the periodic signal.
- a. True
  - b. False

Table 2. Student-t Distribution

v	t <sub>50</sub>	t <sub>90</sub>	t <sub>95</sub>	t <sub>99</sub>
15	0.691	1.753	2.063	2.947
16	0.690	1.746	2.052	2.921
17	0.689	1.740	2.043	2.898
18	0.688	1.734	2.035	2.878
19	0.688	1.729	2.027	2.861
20	0.687	1.725	2.021	2.845
21	0.686	1.721	2.015	2.831
22	0.686	1.717	2.010	2.819
23	0.685	1.714	2.005	2.807
24	0.685	1.711	2.000	2.797
25	0.684	1.708	1.996	2.787
46	0.680	1.679	1.953	2.687
47	0.680	1.678	1.952	2.685
48	0.680	1.677	1.951	2.682
49	0.680	1.677	1.950	2.680
50	0.679	1.676	1.949	2.678

Table 3. Probability Values for Normal Error Function  $z_1 = \frac{x_1 - x'}{\sigma}$

	0	0.01	0.02	0.03	0.04	0.05	0.06	0.07	0.08	0.09
1	0.3413	0.3438	0.3461	0.3485	0.3508	0.3531	0.3554	0.3577	0.3599	0.3621
1.1	0.3643	0.3665	0.3686	0.3708	0.3729	0.3749	0.3770	0.3790	0.3810	0.3830
1.2	0.3849	0.3869	0.3888	0.3907	0.3925	0.3944	0.3962	0.3980	0.3997	0.4015
1.3	0.4032	0.4049	0.4066	0.4082	0.4099	0.4115	0.4131	0.4147	0.4162	0.4177
1.4	0.4192	0.4207	0.4222	0.4236	0.4251	0.4265	0.4279	0.4292	0.4306	0.4319
1.5	0.4332	0.4345	0.4357	0.4370	0.4382	0.4394	0.4406	0.4418	0.4429	0.4441
1.6	0.4452	0.4463	0.4474	0.4484	0.4495	0.4505	0.4515	0.4525	0.4535	0.4545
1.7	0.4554	0.4564	0.4573	0.4582	0.4591	0.4599	0.4608	0.4616	0.4625	0.4633
1.8	0.4641	0.4649	0.4656	0.4664	0.4671	0.4678	0.4686	0.4693	0.4699	0.4706
1.9	0.4713	0.4719	0.4726	0.4732	0.4738	0.4744	0.4750	0.4756	0.4761	0.4767
2	0.4772	0.4778	0.4783	0.4788	0.4793	0.4798	0.4803	0.4808	0.4812	0.4817
2.1	0.4821	0.4826	0.4830	0.4834	0.4838	0.4842	0.4846	0.4850	0.4854	0.4857
2.2	0.4861	0.4864	0.4868	0.4871	0.4875	0.4878	0.4881	0.4884	0.4887	0.4890
2.3	0.4893	0.4896	0.4898	0.4901	0.4904	0.4906	0.4909	0.4911	0.4913	0.4916
2.4	0.4918	0.4920	0.4922	0.4925	0.4927	0.4929	0.4931	0.4932	0.4934	0.4936
2.5	0.4938	0.4940	0.4941	0.4943	0.4945	0.4946	0.4948	0.4949	0.4951	0.4952
2.6	0.4953	0.4955	0.4956	0.4957	0.4959	0.4960	0.4961	0.4962	0.4963	0.4964
2.7	0.4965	0.4966	0.4967	0.4968	0.4969	0.4970	0.4971	0.4972	0.4973	0.4974
2.8	0.4974	0.4975	0.4976	0.4977	0.4977	0.4978	0.4979	0.4979	0.4980	0.4981
2.9	0.4981	0.4982	0.4982	0.4983	0.4984	0.4984	0.4985	0.4985	0.4986	0.4986
3	0.4987	0.4987	0.4987	0.4988	0.4988	0.4989	0.4989	0.4989	0.4990	0.4990