

TANK DRAINING

Introduction

A number of years ago, the following letter was sent to the editor of *Chemical Engineering Magazine*:

What is the Effect of Pipe Length?

Sir:

I would like to get the answer to a hydraulics problem that came up recently here.

Two 2-inch pipes extend from the bottom of an open tank. One is 4 ft long and the other 10 ft long. Both are open at the ends. Which pipe, if either, will drain the tank faster?

Among my associates there are two opposing viewpoints. One is that the longer pipe gives a greater head and thus a greater flow rate. The other is that you cannot increase the flow rate by adding friction to the flow path. Therefore the flow from the shorter pipe will be greater, or the rates will be essentially the same. This argument contends that the true head is only that measured above the bottom of the tank, and the amount leaving the pipe is controlled by the constriction as the liquid enters the pipes.

This problem may seem simple, but out of about 50 engineers concerned, opinion was about equally divided.

John Heitala
Clayton, Mo.

There is much "food for thought" in this question. This experiment seeks to shed some light on this dilemma.

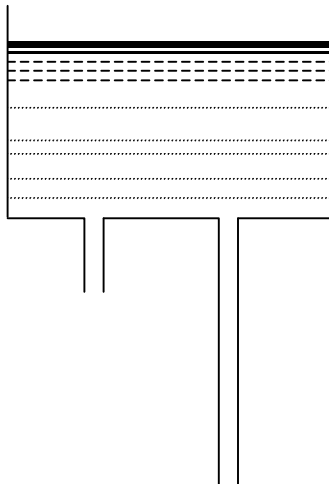

Theory

A. Application of Bernoulli's Equation

Consider the sketch of a tank below:

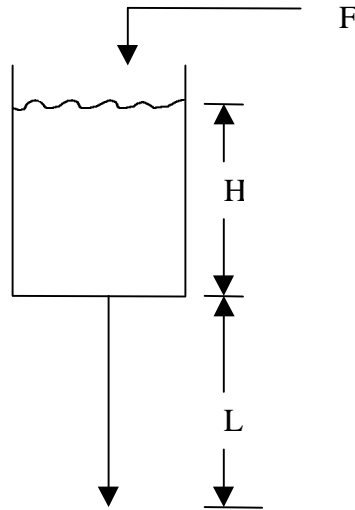

Note that this tank has only one exit line, but it is replaceable with lines having different lengths. Although this experiment concerns the draining of a tank, we will first consider the steady state situation where the flow in, F , is sufficient to maintain the level in the tank at H inches. Bernoulli's equation with friction takes the form:

$$\frac{L+H}{12} = K_c \frac{V^2}{2g} + K_e \frac{V^2}{2g} + K_c \frac{4fLV^2}{2gd} \quad (1)$$

where L = Length of drain pipe, inches
 H = Liquid level above the bottom of the tank, inches
 K_c = Contraction loss coefficient, dimensionless
 K_e = Exit loss coefficient, dimensionless
 V = Velocity in drain tube, ft/s
 g = Gravitational constant, 32.174 ft/s²
 f = Fanning friction factor
 d = Tube diameter, inches

The contraction loss when the flow moves from the tank to the drain pipe is described in McCabe, Smith, and Harriott (MS&H) Fifth Edition on Pages 106-7. For the case of sharp-edged contractions, K_c is given by the Equation (5.66):

$$K_c = 0.4 \left(1 - \frac{S_b}{S_a} \right) \quad (2)$$

where S_a and S_b are the cross-sectional areas of the upstream and downstream conduits, respectively. The ratio, S_b/S_a , arises frequently, and it is therefore convenient to define the parameter, β , as follows:

$$\mathbf{b} = \frac{S_b}{S_a} = \frac{d^2}{D^2} \quad (3)$$

where D = Tank diameter, inches

In the laboratory, the pipe diameter of the tubes is 0.49 inch. There are two tanks. The larger of the two has a diameter of 8.375 inches, and the smaller, 4.0 inches. Thus, β is 0.003423 for the large tank, and 0.01501 for the small tank. Therefore, from Equation (2), it can be seen that K_c can be taken to be 0.40 for both tanks – at least for now.

There are two contraction assemblies which can be placed on either of the tanks. One is sharp-edged and the other is rounded. The estimated coefficient for the rounded unit is 0.02. Some experiments will be performed to determine these coefficients more accurately.

The exit loss coefficient, K_e , is discussed in MS&H on Pages 105-6. In the situation here, the fluid leaving the pipe is not confined – that is, the water is not flowing from the pipe into another conduit or tank; hence, K_e is simply 1.0. Thermodynamically speaking (for those who liked thermo), the “expansion loss” in this case is simply the kinetic energy of the liquid leaving the pipe.

The Fanning friction factor, f , is covered in MS&H beginning on Page 85. *It is important to note that there is another friction factor called the Blasius or Darcy friction factor that is used in some books. It is exactly equal to four times the value of f used in MS&H.* Perry’s Handbook uses the Fanning friction factor as well.

Thus, the final form of Equation (1) is:

$$\frac{L + H}{12} = \left(1.4 + \frac{4fL}{d} \right) \frac{V^2}{2g} \quad (4)$$

At this point, you might wish to check the units through to make sure everything is in order.

The friction factor is a function of the Reynolds number. For turbulent flow through smooth pipes, the Blasius formula may apply, depending upon the Reynolds number involved:

$$f = 0.0791 / \text{Re}^{0.25} \quad 4000 < \text{Re} < 10^5 \quad (5)$$

where $\text{Re} = \frac{\rho d V}{\mu}$ (These parameters must be in consistent units!) (6)

It turns out that in this experiment, the flow rates through the pipes fall within the Reynolds number range for Equation (5).

Beyond the Reynolds number constraint, there are several reasons why this equation might not be applicable to the draining of the tanks. Firstly, the published friction factor plots are the results of studies of fluid flow through pipes in which the flow is steady and the pipes are of sufficient length that the velocity profile is well established. If there is continuous flow into the tank, then eventually, the level reaches a steady state value and the velocity through the exit pipe is constant and, of course, equal to the flow rate in. However, when a tank is draining, the velocity is relatively high at the beginning of the draining process, but decreases as the level drops. Thus, the Reynolds number and friction factor change with time. Previous experiments with the tanks in the laboratory have shown that in spite of this velocity variation, the friction factor does not change very much. This point will be explored in this experiment.

Secondly, there is the matter of the establishment of the velocity profile in the exit line. If the exit line is short, then the distance required for the profile to be established may be a significant fraction of the line length. On the other hand, for long pipes, the establishment of the profile may require only a small fraction of the length. Welty, Wicks, and Wilson 3rd edition states on Page 216: "There is no relation available to predict the entrance length for a fully developed turbulent profile. An additional factor which affects the entrance length in turbulent flow is the nature of the entrance itself. The reader is referred to the work of Deissler (R. G. Deissler, NACA TN 2138 (1950)) for experimentally obtained turbulent velocity profiles in the entrance region of circular pipes. A general conclusion of the results of Deissler and others is that the turbulent velocity becomes fully developed after a minimum distance of 50 diameters downstream from the entrance."

B. Drain Time With No Flow into the Tank.

If the friction factor, f , is a constant, then it is useful to express Equation (4) in the following form:

$$\frac{L + H}{12} = aV^2 \quad (7)$$

$$\text{where } \mathbf{a} = \left(1 + K_c + \frac{4fL}{d} \right) \left(\frac{1}{2g} \right) \quad (8)$$

If K_c and f are constant, then α is constant.

If the tank is draining, then an unsteady state material balance on the tank and exit pipe gives:

$$S_b V = -S_a \frac{dH}{dt} \quad (9)$$

The minus sign is needed because the derivative is negative. Substitution of β , rearrangement, and integration yield:

$$\int_0^{t_e} dt = -\frac{1}{\mathbf{b}} \int_{H_i}^{H_e} \sqrt{\frac{\mathbf{a}/12}{H+L}} dH \quad (10)$$

where t_e = drain time, s
 H_i = initial liquid level, inches
 H_e = final liquid depth, inches

The factor of 12 is required because α has the units of s^2/ft whereas H and L are in inches. After integration, one obtains:

$$t_e = \frac{2\sqrt{\mathbf{a}/12}}{\mathbf{b}} \left\{ \sqrt{H_i + L} - \sqrt{H_e + L} \right\} \quad (11)$$

The initial depth will be 84 inches in most cases; this corresponds to the level of the overflow line. Because it is very difficult to judge when the tank is completely level, the final level will be taken at 1 inch above the bottom.

C. Experimental Plan

(1) Contraction Loss

The contraction loss coefficient can be estimated from runs without a drain pipe. Steady-state runs will be made with both the sharp-edged and rounded contraction assemblies.

(2) Friction Factors

Some steady-state runs will be made with pipes attached to the entrance assemblies. Using the calculated contraction coefficients, the friction factors will be calculated and compared with values from the Blasius Formula and published graphs.

(3) Drain Time

Drain times will be measured for various pipes and contraction assemblies. The results will be compared with values predicted from Equation (11).